

Manual

CC-Link IE Field Basic

LioN-X Low Current Digital-I/O Multiprotocol:

0980 XLC 3900-121-007D-01F (16 × Input/Output)

0980 XLC 3901-121-007D-01F (16 × Input)

0980 XLC 3903-121-007D-01F (8 × Input, 8 × Output
isolated)

0980 XLC 3923-121-007D-01F (8 × Input, 8 × Output)

Contents

1 About this manual	7
1.1 General information	7
1.2 Explanation of symbols	8
1.2.1 Use of danger information	8
1.2.2 Use of general information	8
1.3 Version information	8
2 Safety instructions	9
2.1 Intended use	9
2.2 Qualified personnel	10
3 Designations and synonyms	11
4 System description	14
4.1 Device variants	15
4.2 I/O port overview	16
5 Overview of product features	20
5.1 CC-Link IE Field Basic product features	20
5.2 Integrated Web server	21
5.3 Security features	22
5.4 Other features	23

6 Assembly and wiring	24
6.1 General information	24
6.2 Outer dimensions	25
6.2.1 LioN-X Low Current Digital-I/O multi-protocol variants	25
6.2.2 Notifications	29
6.3 Port assignments	30
6.3.1 Ethernet ports, M12 socket, 4-pin, D-coded	30
6.3.2 Power supply with M12 power L-coded	31
6.3.3 I/O ports as M12 sockets	32
6.3.3.1 I/O ports	33
7 Starting operation	34
7.1 CSP+ file	34
7.2 MAC addresses	34
7.3 State on delivery	35
7.4 Setting the rotary encoding switches	36
7.4.1 CC-Link IE Field Basic	38
7.4.2 Factory reset	38
7.5 Setting network parameters	39
8 Configuration CC-Link IE Field Basic	40
8.1 General settings	41
8.1.1 Report U_L supply voltage fault	42
8.1.2 Report actuator fault without U_L/U_{AUX} voltage	42
8.1.3 Report U_S voltage fault	42
8.1.4 Force mode lock	42
8.1.5 Web interface lock	42
8.1.6 External configuration lock	42
8.2 Port configuration X1 .. X8	43
8.2.1 Surveillance Timeout	44

8.2.2 Failsafe Mode	44
8.2.3 Channel Direction	44
8.2.4 Output Auto Restart	45
8.2.5 Digital Input Logic	45
8.2.6 Digital Input Filter	46
8.2.7 DI Extension	46
8.2.8 IO Mapping	47
9 Process data assignment	48
9.1 Consuming data (output)	49
9.2 Producing data (input)	50
9.3 Measured voltages	50
10 Diagnostics processing	51
10.1 Error of the system/sensor power supply	51
10.2 Error of the auxiliary/actuator power supply	52
10.3 Overload/short circuit of the digital outputs	52
10.4 Overload/short-circuit of the I/O port sensor supply outputs	54
11 Configuration and operation with GxWorks3®	55
11.1 Integration of a CSP+ file	55
11.2 Network parameters	56
11.3 Parameter processing	59
12 IIoT functionality	62
12.1 MQTT	63
12.1.1 MQTT configuration	63
12.1.2 MQTT topics	66

12.1.2.1 Base topic	66
12.1.2.2 Publish topic	69
12.1.2.3 Command topic (MQTT Subscribe)	77
12.1.3 MQTT configuration - Quick start guide	81
12.1.3.1 MQTT configuration via JSON	81
12.2 OPC UA	83
12.2.1 OPC UA configuration	83
12.2.1.1 Gateway objects	86
12.2.1.2 Ports objects	89
12.2.1.3 Channel objects	90
12.2.2 OPC UA address space	92
12.2.3 OPC UA configuration - Quick start guide	93
12.2.3.1 OPC UA configuration via JSON	93
12.3 REST API	95
12.3.1 Standard device information	95
12.3.2 Structure	96
12.3.3 Configuration and forcing	100
12.4 CoAP server	102
12.4.1 CoAP configuration	102
12.4.2 REST API access via CoAP	103
12.4.3 CoAP configuration - Quick start guide	105
12.4.3.1 CoAP configuration via JSON	105
12.5 Syslog	107
12.5.1 Syslog configuration	107
12.5.2 Syslog configuration - Quick start guide	110
12.5.2.1 Syslog configuration via JSON	110
12.6 Network Time Protocol (NTP)	112
12.6.1 NTP configuration	112
12.6.2 NTP configuration - Quick start guide	114
12.6.2.1 NTP configuration via JSON	114

13 The integrated Web server **116**

13.1 LioN-X 0980 XLC... variants	117
13.1.1 The Status page	117

13.1.2 The Ports page	118
13.1.3 The System page	119
13.1.4 The User page	122
14 Technical data	123
14.1 General	124
14.2 CC-Link IE Field Basic protocol	125
14.3 Power supply of the module electronics/sensors	126
14.4 Power supply of the actuators	128
14.5 I/O ports	128
14.5.1 Digital inputs	129
14.5.2 Digital outputs	129
14.6 LEDs	132
14.7 Data transfer times	134
15 Recycling note	136
16 Accessories	137

1 About this manual

1.1 General information

Download the latest version of this document at:

<http://doc.beldensolutions.com>

Please read the assembly and operating instructions in this manual carefully before starting up the devices. Keep the manual where it is accessible to all users.

The texts, figures, diagrams, and examples used in this manual are used exclusively to explain how to operate and apply the devices.

Please contact us if you have any detailed questions on installing and starting up the devices.

Belden Deutschland GmbH
Belden
Im Gewerbepark 2
D-58579 Schalksmühle
Germany

<https://my.belden.com>

<https://www.belden.com>

<https://catalog.belden.com>

1.2 Explanation of symbols

1.2.1 Use of danger information

Danger information is denoted as follows:



Danger: Means that death, serious physical injury or substantial damage to property will occur if the required safety measures are not taken.



Warning: Means that death, serious physical injury or substantial damage to property can occur if the required safety measures are not taken.



Caution: Means that minor physical injury or damage to property can occur if the required safety measures are not taken.

1.2.2 Use of general information

General information is denoted as follows:



Attention: Contains important information on the product, on how to manage the product, or on the respective section of the documentation to which your special attention is being drawn.

1.3 Version information

Version	Created	Changes
1.0	02/2026	

Table 1: Overview of manual revisions

2 Safety instructions

2.1 Intended use

The products described in this manual are decentralized I/O Devices on an Industrial Ethernet Network.

We adhere to all safety standards when developing, producing, testing, and documenting our products. When you adhere to the handling specifications and safety instructions described for the configuration, assembly, and correct operation, there should not normally be any risks for people or equipment.

The modules fulfill the requirements of the EMC guidelines (89/336/EEC, 93/68/EEC and 93/44/EEC) and the low voltage guideline (73/23/EEC).

The devices are designed to be used in the industrial sector. The industrial environment is distinguished by the fact that the consumer is not connected directly to the public low voltage network. Additional measures are required for use in residential areas or in business and commercial sectors.



Attention: This equipment may cause radio interference in residential areas. In this case the operator may be requested to carry out appropriate measures.

The proper and safe operation of this product depends on proper transportation, storage, assembly, and installation, and careful operation.

During the configuration, installation, start-up, maintenance, and testing of the devices, adhere to the safety and accident-prevention guidelines for the specific application.

Only install cables and accessories that fulfill the requirements and regulations for safety, electromagnetic compatibility, and, where applicable, telecommunication end devices, as well as the specification information. Information on which cables and accessories are permitted for the installation can be obtained from Belden Deutschland GmbH or is contained in this manual.

2.2 Qualified personnel

The configuration, installation, start-up, maintenance, and testing of the devices may only be performed by a qualified electrician who is familiar with the safety standards of the automation technology.

The personnel requirements are based on the requirement profiles described by ZVEI, VDMA, or equivalent organizations.

Only electricians who are familiar with the content of this manual are authorized to install and maintain the devices described. These are persons who

- ▶ based on their technical training, knowledge, and experience, and their knowledge of the pertinent standards, can evaluate the work to be carried out and identify any potential risks or
- ▶ based on working for several years in a related sector, have the same level of knowledge as they would have from the relevant technical training.

Only Belden Deutschland GmbH is permitted to make changes to the hardware or software of the products that go beyond the scope of this manual.



Warning: Making unqualified changes to the hardware or software, or non-adherence to the warning information contained in this manual, can result in serious personal injury or damage to equipment.



Attention: Belden Deutschland GmbH accepts no liability for any damage caused by unqualified personnel or improper use. This automatically voids the warranty.

3 Designations and synonyms

AOI	Add-On Instruction
API	Application Programming Interface
BF	Bus Fault LED
Big Endian	Data format with High-B on first place (PROFINET)
BUI	Back-Up Inconsistency (EIP diagnostics)
CC	CC-Link IE Field
Ch. A	Channel A (Pin 4) of I/O port
Ch. B	Channel B (Pin 2) of I/O port
CIP	Common Industrial Protocol (media independent protocol)
CoAP	Constrained Application Protocol
CSP+	Control & Communication System Profile Plus
DCP	Discovery and Configuration Protocol
DevCom	Device Communicating (EIP diagnostics)
DevErr	Device Error (EIP diagnostics)
DI	Digital Input
DIA	Diagnostic LED
DO	Digital Output
DIO	Digital Input/Output
DTO	Device Temperature Overrun (EIP diagnostics)
DTU	Device Temperature Underrun (EIP diagnostics)
DUT	Device under test
EIP	EtherNet/IP
ERP	Enterprise Resource Planning system
ETH	ETHERNET
FE	Functional Earth
FME	Force Mode Enabled (EIP diagnostics)
FSU	Fast Start-Up

GSDML	General Station Description Markup Language
High-B	High-Byte
ICT	Invalid Cycle Time (EIP diagnostics)
IIoT	Industrial Internet of Things
ILE	Input process data Length Error (EIP diagnostics)
IME	Internal Module Error (EIP diagnostics)
I/O	Input / Output
I/O port	X1 .. X8
I/O port pin 2	Channel B of X1 .. X8
I/O port pin 4 (C/Q)	Channel A of X1 .. X8
I&M	Identification & Maintenance
JSON	JavaScript Object Notation (platform independent data format)
L+	I/O port pin 1, sensor power supply
LC	Low Current
LioN-X 60	LioN-X variants with a width of 60mm
Little Endian	Data format with Low-B on first place (EtherNet/IP)
LLDP	Link Layer Discovery Protocol
Low-B	Low-Byte
LSB	Least Significant Bit
LVA	Low Voltage Actuator Supply (EIP diagnostics)
LVS	Low Voltage System/Sensor Supply (EIP diagnostics)
MIB	Management Information Base
MP	Multi-protocol: PROFINET + EtherNet/IP + EtherCAT® + Modbus TCP (+ CC-Link IE Field Basic)
MQTT	Message Queuing Telemetry Transport (open networking protocol)
MSB	Most Significant Bit
M12	Metric thread according to DIN 13-1 with 12 mm diameter
NTP	Network Time Protocol
OLE	Output process data Length Error (EIP diagnostics)
OPC UA	Open Platform Communications Unified Architecture (platform independent, service-oriented architecture)

3 Designations and synonyms

PLC	Programmable Logic Controller
PN	PROFINET
PWR	Power
REST	REpresentational State Transfer
RFC	Request for Comments
RPI	Requested Packet Interval
RWr	Word data input as seen from the master station (CC-Link)
RWw	Word data output as seen from the master station (CC-Link)
RX	Bit data input as seen from the master station (CC-Link)
RY	Bit data output as seen from the master station (CC-Link)
SCA	Short Circuit Actuator/ U_L/U_{AUX} (EIP diagnostics)
SCS	Short Circuit Sensor (EIP diagnostics)
SLMP	Seamless Message Protocol
SNMP	Simple Network Management Protocol
SP	Single Protocol (PROFINET, EtherNet/IP, EtherCAT®, Modbus TCP or CC-Link IE Field Basic)
SPE	Startup Parameterization Error (EIP diagnostics)
UDP	User Datagram Protocol
UDT	User-Defined Data Types
UINT8	Byte in PLC (IB, QB)
UINT16	Unsigned integer with 16 bits or word in PLC (IW, QW)
U_L	U_{Load} , supply voltage for the load circuit
UL	Underwriters Laboratories Inc. (certification company)
UTC	Coordinated Universal Time (Temps Universel Coordonné)

Table 2: Designations and synonyms

4 System description

The LioN modules function as the interface in an industrial Ethernet system: A central controller on the management level is able to communicate with the decentralized sensors and actuators on the field level. The line or ring topologies for which LioN modules can be used ensure not only reliable data communication but also significantly reduce the number of cables required and thus also the costs for installation and maintenance. They additionally enable easy and quick extension.

4.1 Device variants

The following Low Current Digital I/O device variants are available in the LioN-X family:

Article number	Product designation	Description	I/O port functionality
935715001	0980 XLC 3900-121-007D-01F	LioN-X M12-60 mm, I/O Device Multi-protocol (PN, EIP, EC, MB, CC) Security	16 x Input/Output universal
935716001	0980 XLC 3901-121-007D-01F	LioN-X M12-60 mm, I/O Device Multi-protocol (PN, EIP, EC, MB, CC) Security	16 x Input
935717001	0980 XLC 3903-121-007D-01F	LioN-X M12-60 mm, I/O Device Multi-protocol (PN, EIP, EC, MB, CC) Security	8 x Input, 8 x Output Mixmodule, galvanic isolated
935718001	0980 XLC 3923-121-007D-01F	LioN-X M12-60 mm, I/O Device Multi-protocol (PN, EIP, EC, MB, CC) Security	8 x Input, 8 x Output Mixmodule, without galvanic isolation of the outputs

Table 3: Overview of LioN-X Low Current Digital-I/O variants

4.2 I/O port overview

The following tables show the main I/O port differences of the LioN-X family. Pin 4 and Pin 2 of the I/O ports can be configured partly to Digital Input or Digital Output.

LioN-X LC 16DIO ports

Device variant	Port	Pin 1 U _S	Pin 4 / Ch. A (In/Out)		Pin 2 / Ch. B (In/Out)	
0980 XLC 3900...	Info:	–	Type 1	Supply by U _L	Type 1	Supply by U _L
	X8:	U _S (2 A in sum for X1 .. X8)	DI	DO (2 A)	DI	DO (2 A)
	X7:		DI	DO (2 A)	DI	DO (2 A)
	X6:		DI	DO (2 A)	DI	DO (2 A)
	X5:		DI	DO (2 A)	DI	DO (2 A)
	X4:		DI	DO (2 A)	DI	DO (2 A)
	X3:		DI	DO (2 A)	DI	DO (2 A)
	X2:		DI	DO (2 A)	DI	DO (2 A)
	X1:		DI	DO (2 A)	DI	DO (2 A)

Table 4: Port configuration of 0980 XLC 3900... variant

LioN-X LC 16DI ports

Device variant	Port	Pin 1 U _S	Pin 4 / Ch. A (Input)	Pin 2 / Ch. B (Input)
0980 XLC 3901...	Info:	–	Type 1	Type 1
	X8:	U _S (2 A in sum for X1 .. X8)	DI	DI
	X7:		DI	DI
	X6:		DI	DI
	X5:		DI	DI
	X4:		DI	DI
	X3:		DI	DI
	X2:		DI	DI
	X1:		DI	DI

Table 5: Port configuration of 0980 XLC 3901... variants

LioN-X LC 8DI8DO ports with galvanic isolation of the outputs

Device variant	Port	Pin 1 U _S	Pin 4 / Ch. A (In/Out)		Pin 2 / Ch. B (In/Out)	
0980 XLC 3903...	Info:	–	Type 1	Supply by U _L	Type 1	Supply by U _L
	X8:	–	–	DO (2 A)	–	DO (2 A)
	X7:	–	–	DO (2 A)	–	DO (2 A)
	X6:	–	–	DO (2 A)	–	DO (2 A)
	X5:	–	–	DO (2 A)	–	DO (2 A)
	X4:	U _S (2 A in sum for X1 .. X4)	DI	–	DI	–
	X3:		DI	–	DI	–
	X2:		DI	–	DI	–
	X1:		DI	–	DI	–

Table 6: Port configuration of 0980 XLC 3903... variants

LioN-X LC 8DI8DO ports without galvanic isolation of the outputs

Device variant	Port	Pin 1 U _S	Pin 4 / Ch. A (In/Out)		Pin 2 / Ch. B (In/Out)	
0980 XLC 3923...	Info:	–	Type 3	Supply by U _L	Type 3	Supply by U _L
	X8:	–	–	DO (2 A)	–	DO (2 A)
	X7:	–	–	DO (2 A)	–	DO (2 A)
	X6:	–	–	DO (2 A)	–	DO (2 A)
	X5:	–	–	DO (2 A)	–	DO (2 A)
	X4:	U _S (200 mA)	DI	–	DI	–
	X3:	U _S (200 mA)	DI	–	DI	–
	X2:	U _S (200 mA)	DI	–	DI	–
	X1:	U _S (200 mA)	DI	–	DI	–

Table 7: Port configuration of 0980 XLC 3923... variants

5 Overview of product features

5.1 CC-Link IE Field Basic product features

CC-Link IE Field Basic network

- ▶ Number of stations: 1
- ▶ RX – 64 bits (per station)
- ▶ RY – 64 bits (per station)
- ▶ RWw – 32 words (per station)
- ▶ RWr – 32 words (per station)

Data connection

The connection option provided by LioN-X is the widely-used M12 connector with D-coding for the CC-Link IE Field Basic network.

The connectors are also color-coded to prevent the ports from being mixed up.

Data transmission rates

Featuring a transmission rate of up to 100 MBit/s, the CC-Link IE Field Basic devices can handle both fast transmission of I/O data and transmission of larger volumes of data.

Diagnostic data

The devices support diagnosis flags and extended diagnostic data that can be appended to the I/O data.

5.2 Integrated Web server

Network parameter display

Get an overview of network parameters such as the IP address, subnet mask and gateway.

Displaying diagnostics

View diagnostics via the integrated Web server.

User management

Use the integrated Web server for convenient management of all users.

5.3 Security features

Firmware signature

The official firmware update packages contain a signature which helps prevent the system against manipulated firmware updates.

Syslog

The LioN-X multi-protocol variants support the traceability of messages centrally managed and logged via Syslog.

User manager

The Web server provides a user manager to help protect the Web interface against unauthorized access. You can manage the users by groups with different access levels “Admin” or “Write”.

Default user settings:

User: admin

Password: private



Attention: Change the default settings to help protect the device against unauthorized access.

5.4 Other features

Interface protection

The devices have reverse polarity, short-circuit and overload protection for all interfaces.

For more details, see section [Port assignments](#) on page 30.

Failsafe

The devices support a failsafe function. This allows you to define the behavior of every single channel configured as an output in the case of invalid PLC data (e.g. PLC in STOP) or of lost PLC communication.

Industrial Internet of Things

LioN-X is industry 4.0 ready and supports the integration in IIoT networks via REST API and the IIoT-relevant protocols MQTT, OPC UA and CoAP.

Color-coded connectors

The colored connectors help you avoid confusion in your cabling.

IP protection classes: IP65 / IP67 / IP69K

The IP protection class describes environmental influences that the devices can be exposed to without risk and without suffering damage or causing a risk for the user.

The whole LioN-X family offers IP65, IP67 and IP69K.

6 Assembly and wiring

6.1 General information

Mount the device on a flat surface using 2 screws (M4x 25/30). The torque required here is 1 Nm. Use washers for all fastening methods as per DIN 125.



Attention: The devices have a ground connection with an M4 thread for the conduction of interference currents and the EMC immunity. This is labeled with the symbol for the ground and the designation "FE".



Attention: Use a low-impedance connection to connect the device to the reference ground. When using a grounded mounting surface, you can make the connection directly via the fixing screws.



Attention: If the mounting surface is ground-free, use a ground strap or a suitable FE line (FE = Functional Earth). Use an M4 screw to connect the ground strap or the FE line to the ground point and if possible put a washer and a toothed washer below the fixing screw.

6.2 Outer dimensions

6.2.1 Lion-X Low Current Digital-I/O multi-protocol variants

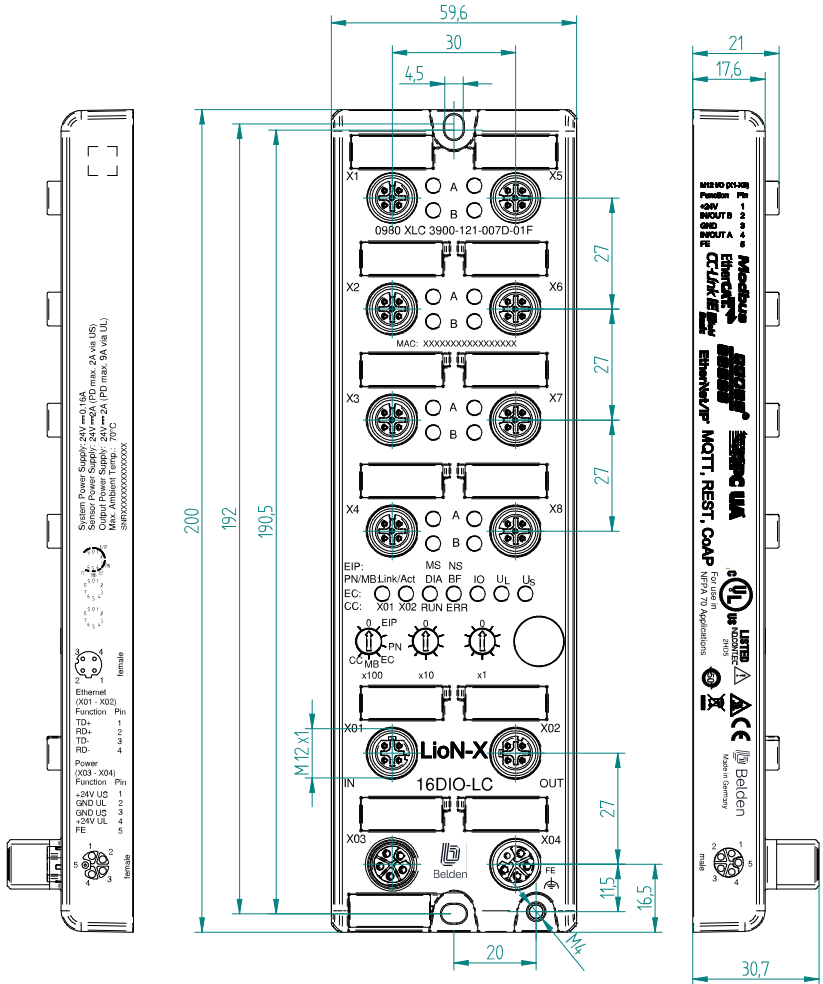

Figure 1: 0980 XLC 3900-121-007D-01F

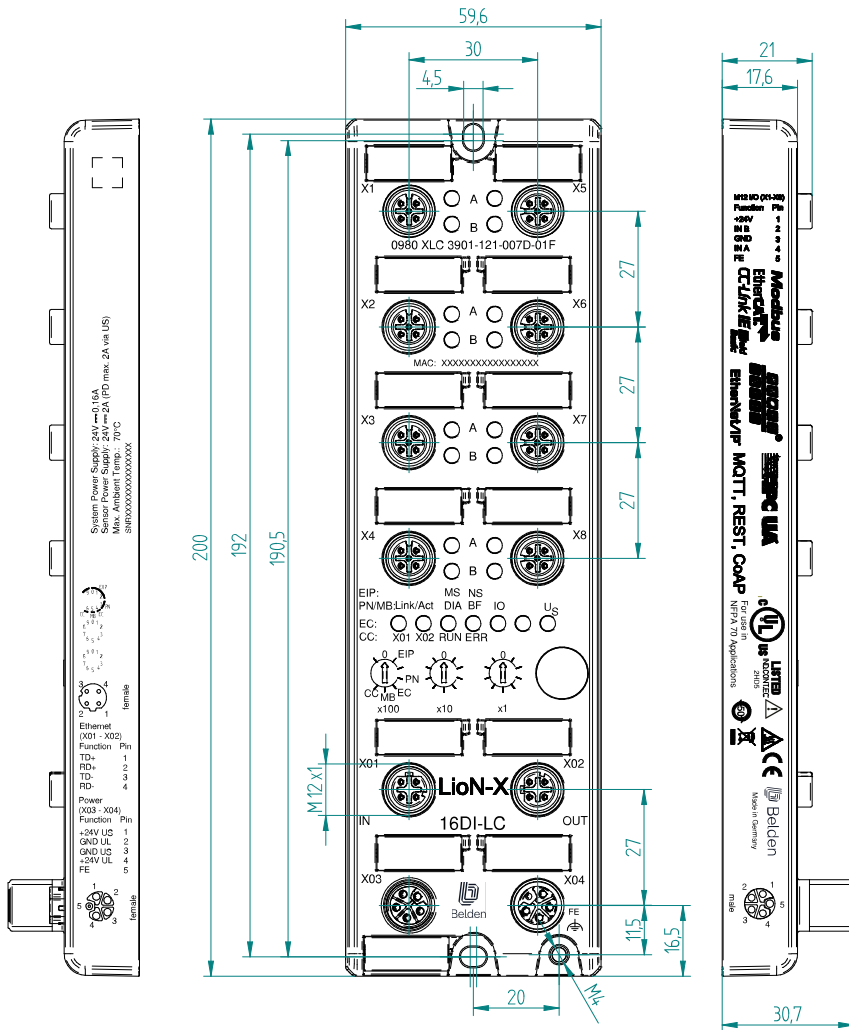

Figure 2: 0980 XLC 3901-121-007D-01F

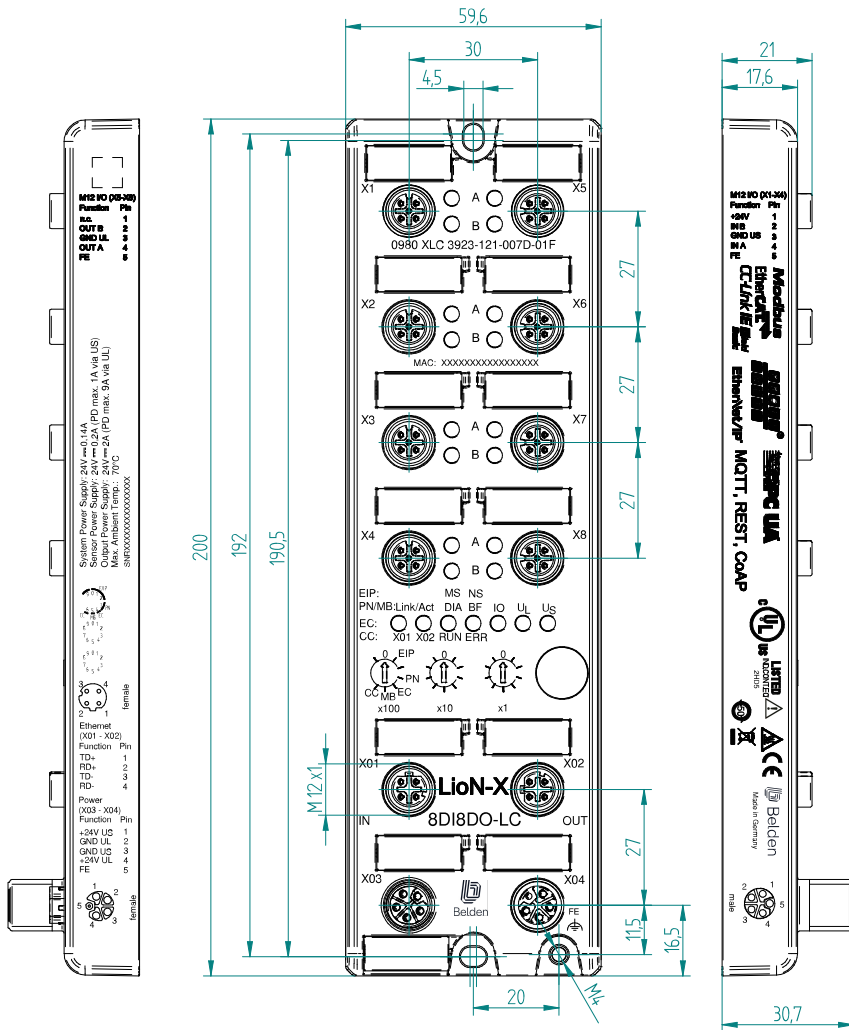

Figure 4: 0980 XLC 3923-121-007D-01F

6.2.2 Notifications



Attention:

For **UL applications**, be sure to use a UL-certified cable with a suitable evaluation to connect the devices (CYJV or PVVA). To program the control, please refer to the OEM information, and only use suitable accessories.

Only approved for interior use. Please note the maximum elevation of 2000 meters. Approved up to a maximum soiling level of 2.



Warning: Terminals, housings field-wired terminal boxes or components can exceed temperatures of +60 °C (140 °F).



Warning: For **UL applications** at a maximum ambient temperature of +70 °C (158 °F):

Use temperature-resistant cables with heat resistance up to at least +125 °C (257 °F) for all device variants.

6.3 Port assignments

All the contact arrangements shown in this chapter show the frontal view of the connection area for the connectors.

6.3.1 Ethernet ports, M12 socket, 4-pin, D-coded

Color coding: green

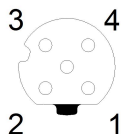

Figure 5: Schematic drawing, ports X01, X02

Port	Pin	Signal	Function
Ethernet Ports X01, X02	1	TD+	Transmit data plus
	2	RD+	Receive data plus
	3	TD-	Transmit data minus
	4	RD-	Receive data minus

Table 8: Assignment of ports X01, X02



Caution: Risk of destruction! Never connect the power supply to the data cables.

6.3.2 Power supply with M12 power L-coded

Color coding: gray

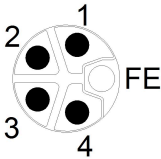

Figure 6: Schematic diagram of the M12 L-coding (connector X03 for Power In)

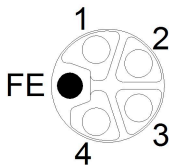

Figure 7: Schematic diagram of the M12 L-coding (socket X04 for Power Out)

Power supply	Pin	Signal	Function
	1	U_S (+24 V)	Sensor/system power supply
	2	GND_ U_L	Ground/reference potential U_L
	3	GND_ U_S	Ground/reference potential U_S
	4	U_L (+24 V)	Load supply Actuator supply
	5	FE	Functional ground

Table 9: Pin assignments ports X03 and X04



Attention: Only use power supply units for the system/sensor and actuator supply that correspond to PELV (Protective Extra Low Voltage) or SELV (Safety Extra Low Voltage). Power supplies according to EN 61558-2-6 (transformers) or EN 60950-1 (switching power supply units) fulfill these requirements.



Attention: For the input module 0980 XLC 3901..., the two contacts 1 and 5 are not required for the voltage supply of the actuator. Nevertheless, these two contacts are bridged together on the plug and socket side to enable a 5-pole forwarding of the voltage supply to a subsequent module.

6.3.3 I/O ports as M12 sockets

Color coding: black

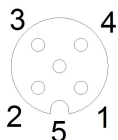

Figure 8: Schematic drawing I/O port as M12 socket

6.3.3.1 I/O ports

0980 XLC 3900...	Pin	Signal	Function
16DIO X1 .. X8	1	+24 V	power supply +24 V
	2	IN/OUT	Ch. B: Digital input or digital output
	3	GND	Ground/reference potential
	4	IN/OUT	Ch. A: Digital input or digital output
	5	FE	Functional ground
0980 XLC 3901...	Pin	Signal	Function
16DI X1 .. X8	1	+24 V	power supply +24 V
	2	IN	Ch. B: Digital input
	3	GND U _S	Ground/reference potential
	4	IN	Ch. A: Digital input
	5	FE	Functional ground
0980 XLC 3903... 0980 XLC 3923...	Pin	Signal	Function
8DI8DO X1 .. X4	1	+24 V	power supply +24 V
	2	IN	Ch. B: Digital input
	3	GND U _S	Ground/reference potential
	4	IN	Ch. A: Digital input
	5	FE	Functional ground
8DI8DO X5 .. X8	1	n.c.	–
	2	OUT	Ch. B: Digital output
	3	GND U _L	Ground/reference potential
	4	OUT	Ch. A: Digital output
	5	FE	Functional ground

Table 10: Pin assignments I/O ports

7 Starting operation

7.1 CSP+ file

The CSP+ file describes the information of a CC-Link device and can be installed in the engineering tool to configure the LioN-X variants. Each of the LioN-X device variants requires its own CSP+ file. The file can be downloaded from the product pages on our online catalog: <https://catalog.belden.com>

On request, the CSP+ file is also sent by the support team.

The CSP+ file and the required icons are grouped together in an archive file named "0x4338_0980 XLC 3900-121-007D-01F_1.0_en.CSPP.zip".

"0x4338" stands for the vendor ID of Belden Deutschland GmbH, "0980 XLC 3900-121-007D-01F" is the model number of the LioN-X variant.

Download the CSP+ file and install it for the respective device variant by using the hardware or network configuration tool of your controller manufacturer.

In GxWorks®, install the files with the CSP+ Hardware Installation Tool. See chapter [Configuration and operation with GxWorks3](#) on page 55.

7.2 MAC addresses

Every device has three unique assigned MAC addresses that cannot be changed by the user. The first assigned MAC address is printed onto the device.

7.3 State on delivery

CC-Link IE Field Basic parameters in state on delivery or after a factory reset:

Network mode:	Static
Static IP address:	192.168.3.XXX (XXX = rotary switch position or last stored data) 192.168.3.1 (default IP – if started with rotary switch position 6-0-0)
Subnet mask:	255.255.255.0
Gateway address	192.168.3.100
Device designations:	0980 XLC 3900-121-007D-01F 0980 XLC 3901-121-007D-01F 0980 XLC 3903-121-007D-01F 0980 XLC 3923-121-007D-01F
Vendor code:	1247 (Hexadecimal: 17208)
Product type:	CC-Link IE Field Basic Slave Station

7.4 Setting the rotary encoding switches

The following LioN-X variants support multi-protocol application for the protocols EtherNet/IP (E/IP), PROFINET (P), EtherCAT® (EC), Modbus TCP (MB) and CC-Link IE Field Basic (CC):

- ▶ 0980 XLC 3900-121-007D-01F
- ▶ 0980 XLC 3901-121-007D-01F
- ▶ 0980 XLC 3903-121-007D-01F
- ▶ 0980 XLC 3923-121-007D-01F



Caution: Risk of device damage due to corrupt device memory

Any interruption of the power supply to the device during and after protocol selection can lead to a corrupt device memory.

After selecting a protocol followed by a restart of the device, the new protocol is initialized. This can take up to 15 seconds. During this time the device is not usable and the LED indicators are out of function. When the protocol change is complete, the LED indicators return to normal operation and the device can be used again.

- ▶ Make sure that the power supply is maintained during the entire process.

The LioN-X multi-protocol variants allow you to select different protocols for communication within an industrial Ethernet system. In this way Digital I/O devices with multi-protocol function can be integrated into different networks without it being necessary to purchase products specific for each protocol. This technology also gives you the option to use the same I/O Device in different environments.

Using rotary encoding switches at the lower front of the devices, you can easily and conveniently set both the protocol and the address of the device, if the protocol to be used supports this. Once you have made a protocol selection and started the cyclical communication, the device stores this setting permanently and uses the selected protocol from this point on. To use another supported protocol with this device, perform a factory reset.

The multi-protocol devices have a total of three rotary encoding switches. With the first rotary encoding switch (x100) you set the protocol by using the

corresponding switch position. Additionally, x100 is used to set the third last digit of the IP address for EIP.

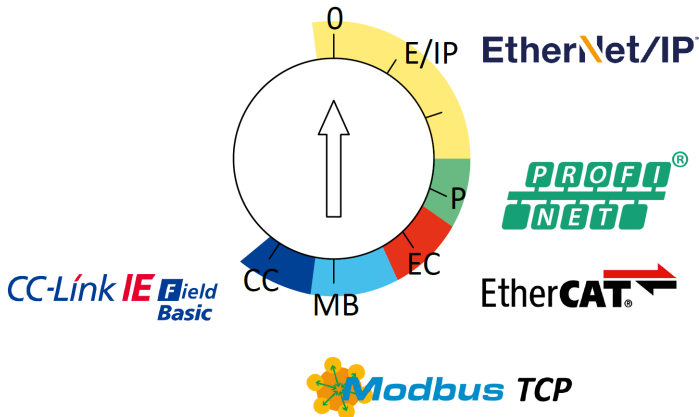

With the other rotary encoding switches (x10 / x1), you set the last two digits of the IP address when you are using EtherNet/IP, Modbus TCP or CC-Link IE Field Basic.

Protocol	x100	x10	x1
EtherNet/IP	0-2	0-9	0-9
PROFINET	P	–	–
EtherCAT®	EC	–	–
Modbus TCP	MB	0-9	0-9
CC-Link IE Field	CC	0-9	0-9

Table 11: Assignment of the rotary encoding switches for each protocol

The setting you make to select a protocol is described detailed in the protocol-specific sections.

In delivery state no protocol settings are stored in the device. In this case only the desired protocol has to be chosen. To take over a changed rotary encoding switch setting (protocol setting), a power cycle or “Reset” from the Web interface is necessary.

Once you have set the protocol using the rotary encoding switches, the device stores this setting when it starts in cyclic communication. Changing

the protocol using the rotary encoding switch is no longer possible after this point. The device will always start using the stored protocol from that point on. The IP address can be changed depending on the selected protocol.

To change the protocol, carry out a factory reset. In this way you restore the factory settings of the respective device. How you perform the factory reset for your device is described in chapter [Factory reset](#) on page 38.

7.4.1 CC-Link IE Field Basic

If you decide to use CC-Link IE Field Basic as a protocol, use the first rotary encoding switch to select the protocol. The second rotary encoding switch (x10) can be used to configure the 10 position of the last octet of the IP address, and the third rotary encoding switch (x1) allows you to configure the 1 position. Values between 0 and 9 can be selected for the second and third switches. The first three octets of the IP address are set by default to 192.168.3.

For example, the rotary encoding switch setting 6(x100), 1(x10) and 0(x1) gives you an IP address of 192.168.3.10 for CC-Link IE Field Basic. It is only possible to assign IP addresses between 192.168.3.1 and 192.168.3.99 for CC-Link IE Field Basic via the rotary switches.

Rotary switch setting	Function
600 (network parameters already saved)	The network parameters last saved are used (IP address, subnet mask, gateway address).
600 ... 699	The last 2 digits of the saved or preset IP address are overwritten by the setting of the rotary switch.
979	The device performs a reset to the factory settings. The network parameters are also reset to the default values. Communication is not possible in this operation mode.

Table 12: Setting options of the rotary encoding switches for CC-Link IE Field Basic

7.4.2 Factory reset

A factory reset restores the original factory settings and thus resets the changes and settings you have made up to that point. It also resets the protocol selection. To perform a factory reset, set the first rotary encoding switch (x100) to 9, the second (x10) to 7, and the third (x1) also to 9.

Afterwards perform a power cycle and wait 10 seconds due to internal memory write processes.

During the factory reset, the U_S LED is blinking red. After the internal memory write processes have finished, the U_S LED returns to display static green or red light, in dependency of the actual U_S voltage.

	x100	x10	x1
Factory Reset	9	7	9

Follow the steps from section [Setting the rotary encoding switches](#) on page 36 again to select a new protocol.

For performing a factory reset via software configuration, see chapter [OPC UA configuration](#) on page 83 and the configuration section.

7.5 Setting network parameters

Use the two right-hand rotary switches (x10 and x1) on the front of the device to set the last octet of the static IP address. Each rotary switch in the range of CC-Link IE Field Basic is assigned to one decimal digit, so that you can configure a number between **0 – 99**. During startup, the position of the rotary switches is typically read within one time cycle.

The complete IP address, the subnet mask, the gateway address and the network mode can be configured and stored via the Web server or any other available configuration interfaces. New configuration interfaces can only be applied to after a restart of the device.

For additional information, see chapter [Setting the rotary encoding switches](#) on page 36.

8 Configuration CC-Link IE Field Basic

Parameters of the LioN-X device can be configured via SLMP, the Web server or IloT protocols. Acyclic messages over SLMP are sent to read and write the configuration. When sending, all existing parameters will be overwritten by this data. Therefore the content of the SLMP messages has the highest valence.

To avoid parameter overwriting by the Web server or IloT protocols during operation, some lock parameters can be enabled in the PLC configuration respectively in the configuration assembly.

Certain configuration parameters apply only to Digital Outputs or only to Digital Inputs. For these to be effective, the corresponding channel must have output or input functionality and must also be configured accordingly.

Configuration parameter	Applicable for channel configuration (port mode)
Surveillance Timeout	DIO, DO (parameter only applicable for digital output function)
Failsafe	DIO, DO (parameter only applicable for digital output function)
Auto Restart	DIO, DO (parameter only applicable for digital output function)
Input Filter Time	DIO, DI (parameter only applicable for digital input function)
Input Logic	DIO, DI (parameter only applicable for digital input function)
DI Extension	DIO, DI (parameter only applicable for digital input function)

The following chapters represent different setting groups with its configuration parameters.

8.1 General settings

Setting	Description	Default value
Suppress U _L Diagnosis Mode	0 = Diagnosis enabled 1 = Diagnosis suppressed 2 = Auto	0
Suppress Actuator Diagnosis without U _L	0 = Diagnosis enabled 1 = Diagnosis suppressed	0
Suppress U _S Diagnosis	0 = Diagnosis enabled 1 = Diagnosis suppressed	0
Reserved	Reserved	0
Web Interface Lock	0 = Web Interface enabled 1 = Web Interface locked	0
Forcing Lock	0 = Forcing Lock disabled 1 = Forcing Lock enabled	0
Reserved	Reserved	0
Reserved	Reserved	0
External Configuration Lock	0 = External configuration enabled 1 = External configuration locked	0

8.1.1 Report U_L supply voltage fault

During commissioning, it is possible that no power supply is connected to the U_L pins. Therefore it can be helpful to suppress and disable the *Report U_L supply voltage fault* diagnosis.

8.1.2 Report actuator fault without U_L/U_{AUX} voltage

During commissioning, it is possible that no power supply is connected to the U_L/U_{AUX} pins. Therefore it can be helpful to suppress and disable the *Report actuator fault without U_L/U_{AUX} voltage* diagnosis.

8.1.3 Report U_S voltage fault

During commissioning, it is possible that no power supply is connected to the U_S pins. Therefore it can be helpful to suppress and disable the *Report U_S voltage fault* diagnosis.

8.1.4 Force mode lock

The input and output process data can be forced via different interfaces (e.g. Web interface, REST, OPC UA, MQTT). The support of interfaces depends on the available software features. If the *Force mode lock* is enabled, it is no longer possible to force input and output process data through these interfaces.



Danger: Risk of physical injury or death! Unattended forcing can lead to unexpected signals and uncontrolled machine movements.

8.1.5 Web interface lock

The Web interface access can be configured. If *Web interface lock* is enabled, the Web pages are no longer reachable.

8.1.6 External configuration lock

Configuration parameters can be set via different alternative interfaces (e.g. Web interface, REST, OPC UA, MQTT). An external configuration can only be done, if no cyclic PLC connection is active. Every new PLC configuration overwrites the external configuration settings.

8.2 Port configuration X1 .. X8

Setting	Description	Default value
Surv. Timeout X1.A .. X8.B	DO Surveillance Timeout Valid values: 0 .. 255	80
Failsafe Mode X1.A .. X8.B	Failsafe mode 0: Set Low 1: Set High 2: Hold Last	0
Direction X1.A .. X8.B	Port mode 0: Digital DIO (16DIO only) 1: Digital Output (16DIO / 8DI8DO only) 2: Digital Input 3: Inactive	16DIO: X1 .. X8 = '0' 16DI: X1 .. X8 = '2' 8DI8DO: X1 .. X4 = '2' / X5 .. X8 = '1'
Output Auto Restart X1.A .. X8.B	DO Restart 0: Disable 1: Enable	1
Digital Input Logic X1.A .. X8.B	Digital Input Logic 0: Normally Open 1: Normally Close	0
Digital Input Filter X1.A .. X8.B	Digital Input Filter 0: Disable 10: 1 ms 20: 2 ms 30: 3 ms 60: 6 ms 100: 10 ms 150: 15 ms	0
DI Extension X1.A .. X8.B	0: Disable 1: 8 ms 2: 16 ms 3: 64 ms	0
I/O Map channel X1.A .. X8.B	I/O Map channel	X1 .. X16

8.2.1 Surveillance Timeout

The digital output channels are monitored during runtime. The error states are detected and reported as a diagnosis. To avoid error states during the switching of output channels, the surveillance timeout can be configured as a delay with deactivated monitoring.

The delay time begins with a rising edge of the output control bit. After delay time has elapsed, the output is monitored and error states are reported by diagnosis. When the channel is permanently switched on or off, the typical filter value (not changeable) is 5 ms.

8.2.2 Failsafe Mode

The LioN-X devices support a failsafe function for the output data of the digital channels. In case of an internal device error, the PLC is in STOP state and cannot provide valid process data. The connection is interrupted or the communication is lost. The output data of the digital channels is controlled by the configured failsafe values.

Set Low:

If failsafe is active, all bits of the digital output data are set to low ("0").

Set High:

If failsafe is active, all bits of the digital output data are set to high ("1").

Hold Last:

If failsafe is active, all bits of the digital output data are holding the last valid process data state ("0" or "1").

8.2.3 Channel Direction

Digital Input/Output (DIO):

In this mode, the channel operates as digital input/output. The channel can be controlled by the *Digital Output Channel Control* (first two bytes of the output data) and the channel state can be seen in the *Digital Input Channel Status* of the cyclic process data.

Digital Output:

In this mode, the channel operates as digital output. The channel can be controlled by the *Digital Output Channel Control* (first two bytes of the output data).

Digital Input:

In this mode, the channel operates as digital input. The channel state can be seen in the *Digital Input Channel* status of the cyclic process data.

Deactivated:

The channel is deactivated but can be configured for later use. No diagnostics are generated.

8.2.4 Output Auto Restart

In case of a short circuit or overload at an output channel, a diagnosis is reported and the output is switched to "off".

If *Output Auto Restart* for this channel is enabled, the output will automatically be turned on again after a fix time delay for checking if the overload or short circuit condition is still active. When it is active, the channel is switched off again.

If *Output Auto Restart* is disabled, the output channel is not automatically turned on again. It can be turned on after a logical reset of the process output data of the channel.

8.2.5 Digital Input Logic

The logical state of an input channel can be configured via these parameters. If a channel is set to "Normally Open", a low signal ("0") is transferred to the process input data (e.g. if a non-damped sensor has an open switching output).

If a channel is set to "Normally Close", a high signal ("0") is transferred to the process input data (e.g. if a non-damped sensor has a closed switching output).

The channel LED shows, independent of these settings, the physical input state of the port pin.

8.2.6 Digital Input Filter

A filter time (in ms) for every digital input channel can be configured by these parameters. When there is no need for a filter it can be disabled. Given values must be divided by '10' to get the actual filter time in ms.

Example: Value "100" = 10 ms

8.2.7 DI Extension



Note: Only applicable for firmware version 11.2 or higher in combination with the latest [device description file](#).

This parameter extends the duration of the digital input status after a state change at the physical input, when the input state change is faster than the extension time set.

The extension time will be applied on 'high' to 'low' and 'low' to 'high' input transitions. This setting only works for channels that have been set to 'digital input'.

Example:

The DI extension parameter is set to 16 ms, the physical input signal has low status => a high signal is detected for 8 ms.

In this case, the DI channel reports a high-status signal for 16 ms, regardless of other physical input signal transitions during this time.

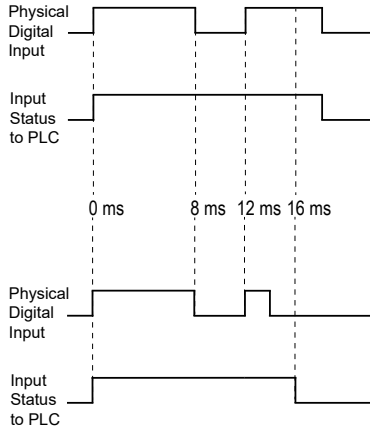

Figure 9: DI Extension

Default: Off (0)

8.2.8 IO Mapping

These configuration parameters can be used to set a user defined IO mapping. It is valid for the input and output data direction. Double assignments are not allowed.

9 Process data assignment

The LioN-X devices in general support process data communication in both directions. The consuming data in this context is defined as the process output data which controls physical outputs. The producing data in this context is defined as the process input data which contains the physical inputs, standard diagnostics and optional extended diagnostics.

The following sections describe the data images for the consuming and producing data direction which are assigned to the output and input assemblies.



Attention: Depending on the engineering tool used, the numbering of the registers is displayed as octal, decimal or hexadecimal.

9.1 Consuming data (output)

Channel No.	Register for DO (single bit)	Description	Access
X1	Y0	Digital Output control for X1	RW ("Read/Write")
X2	Y1	Digital Output control for X2	RW
X3	Y2	Digital Output control for X3	RW
X4	Y3	Digital Output control for X4	RW
X5	Y4	Digital Output control for X5	RW
X6	Y5	Digital Output control for X6	RW
X7	Y6	Digital Output control for X7	RW
X8	Y7	Digital Output control for X8	RW
X9	Y8	Digital Output control for X9	RW
X10	Y9	Digital Output control for X10	RW
X11	YA	Digital Output control for X11	RW
X12	YB	Digital Output control for X12	RW
X13	YC	Digital Output control for X13	RW
X14	YD	Digital Output control for X14	RW
X15	YE	Digital Output control for X15	RW
X16	YF	Digital Output control for X16	RW

9.2 Producing data (input)

Channel No.	Register for DI (single bit)	Description	Access
X1	X0	Digital Input for X1	R ("Read Only")
X2	X1	Digital Input for X2	R
X3	X2	Digital Input for X3	R
X4	X3	Digital Input for X4	R
X5	X4	Digital Input for X5	R
X6	X5	Digital Input for X6	R
X7	X6	Digital Input for X7	R
X8	X7	Digital Input for X8	R
X9	X8	Digital Input for X9	R
X10	X9	Digital Input for X10	R
X11	XA	Digital Input for X11	R
X12	XB	Digital Input for X12	R
X13	XC	Digital Input for X13	R
X14	XD	Digital Input for X14	R
X15	XE	Digital Input for X15	R
X16	XF	Digital Input for X16	R

9.3 Measured voltages

Voltage	Register for voltage (word)	Description	Access
U_S	Wr16	U_S voltage in [mV]	R ("Read Only")
U_L	Wr17	U_L voltage in [mV]	R

10 Diagnostics processing

Sr. No.	Register for Diagnosis	Name	Description	Access
1	X28	U _S supply fault	System supply voltage diagnosis	R ("Read only")
2	X29	U _L supply present	Actuator supply valid range	R
3	X2A	U _L supply fault	Actuator supply fault diagnosis	R
4	X2B	Internal module error	I/O data not reliable due to internal error	R
5	X2C	Force mode diagnosis	Force mode enabled or disabled. Outputs can differ from CC-Link IE Field Basic output values.	R

10.1 Error of the system/sensor power supply

The voltage value for the incoming system/sensor power supply is also monitored globally. If the voltage drops below approx. 18 V, or exceeds approx. 30 V, an error diagnosis is generated.

The green U_S indicator is off.

The error diagnosis has no effect on the outputs.



Caution: It must definitely be ensured that the supply voltage, measured at the most remote participant is not below 18 V DC from the perspective of the system power supply.

10.2 Error of the auxiliary/actuator power supply

The voltage value for the incoming auxiliary/actuator power supply is also monitored globally. If *Report U_L/U_{Aux} Supply Voltage Fault* is enabled, an error message is generated when the voltage drops below approx. 18 V or exceeds approx. 30 V. The U_L/U_{Aux} indicator shows red.

If output channels are set to *High State* and *Report DO Fault without U_L/U_{Aux}* , additional error diagnostics, caused by the voltage failure, are generated on the channels.

If *Report U_L/U_{Aux} Supply Voltage Fault* is disabled, no U_L/U_{Aux} or channel diagnostics appear.

10.3 Overload/short circuit of the digital outputs

In case of an overload or a short circuit of an output channel, the following channel-specific diagnostics are generated in the producing data image.

Port No.	Register for Diagnosis	Description	Access
X1	X10	Short circuit X1 Channel A	R ("Read only")
X2	X11	Short circuit X1 Channel B	R
X3	X12	Short circuit X2 Channel A	R
X4	X13	Short circuit X2 Channel B	R
X5	X14	Short circuit X3 Channel A	R
X6	X15	Short circuit X3 Channel B	R
X7	X16	Short circuit X4 Channel A	R
X8	X17	Short circuit X4 Channel B	R
X9	X18	Short circuit X5 Channel A	R
X10	X19	Short circuit X5 Channel B	R
X11	X1A	Short circuit X6 Channel A	R
X12	X1B	Short circuit X6 Channel B	R
X13	X1C	Short circuit X7 Channel A	R
X14	X1D	Short circuit X7 Channel B	R
X15	X1E	Short circuit X8 Channel A	R
X16	X1F	Short circuit X8 Channel B	R

A channel error is determined by comparing the target value set of a controller to the physical value of an output channel.

When an output channel is activated (rising edge of the channel state), the channel errors are filtered for the period that is set by the *Surveillance Timeout*

parameter via the configuration of the device. The value of this parameter can range from 0 to 255 ms; the default setting is 80 ms.

The filter is used to avoid premature error messages when a capacitive load is activated or an inductive load is deactivated, and during other voltage peaks when a status changes.

10.4 Overload/short-circuit of the I/O port sensor supply outputs

In case of an overload or a short circuit between pin 1 and pin 3 on the ports (X1 .. X8), the following channel-specific diagnostics in the producing data image are generated.

Port No.	Register for Diagnosis	Description	Access
X1	X20	X1 sensor short circuit	R ("Read only")
X2	X21	X2 sensor short circuit	R
X3	X22	X3 sensor short circuit	R
X4	X23	X4 sensor short circuit	R
X5	X24	X5 sensor short circuit	R
X6	X25	X6 sensor short circuit	R
X7	X26	X7 sensor short circuit	R
X8	X27	X8 sensor short circuit	R

11 Configuration and operation with GxWorks3®

The configuration and start-up of LioN-X devices described in this chapter refers to the Mitsubishi Engineering Tool GxWorks®, V2. If you are using an engineering tool from another provider, please consider the related documentation.

11.1 Integration of a CSP+ file

Perform the following work steps to integrate a CSP+ file in GxWorks3®:

1. Open GxWorks3® and navigate to **Tool > Profile Management > Register**.

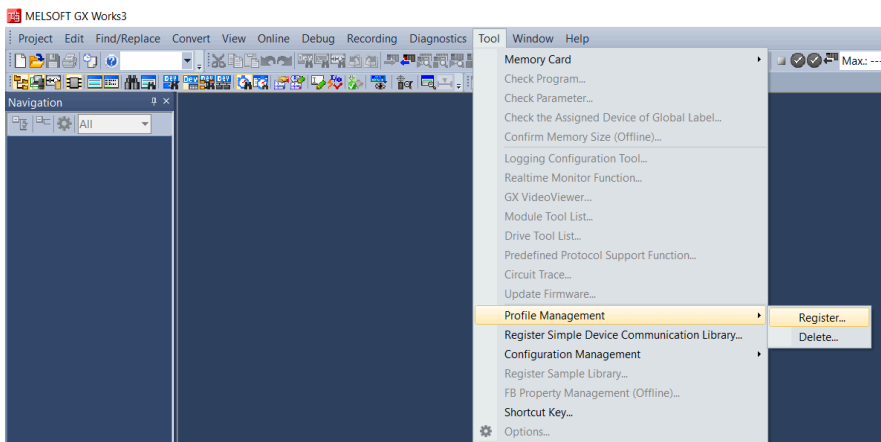

2. Select *0x4338_0980_XXX_1.0_en.CSPP.zip* and the CSP+ file will be registered.

11.2 Network parameters

Perform the following work steps to change the Network parameters:

1. Open GxWorks3® and create a new project.
2. Select the series and the type of the used PLC.

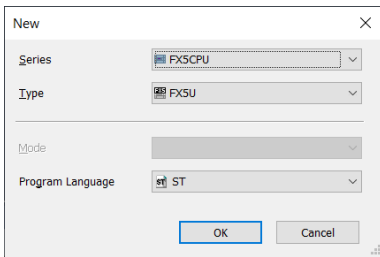

3. To open the setting window, navigate to **Project > Parameter > "the selected CPU module" > Module Parameter**

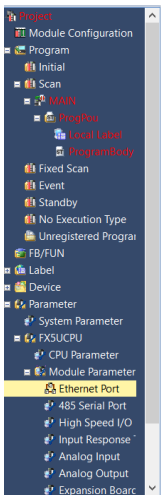

In the appearing window, the CC-Link IE Field Basic Master station can be configured.

4. Navigate to *Own Node Settings* to configure the PLC or Master station.

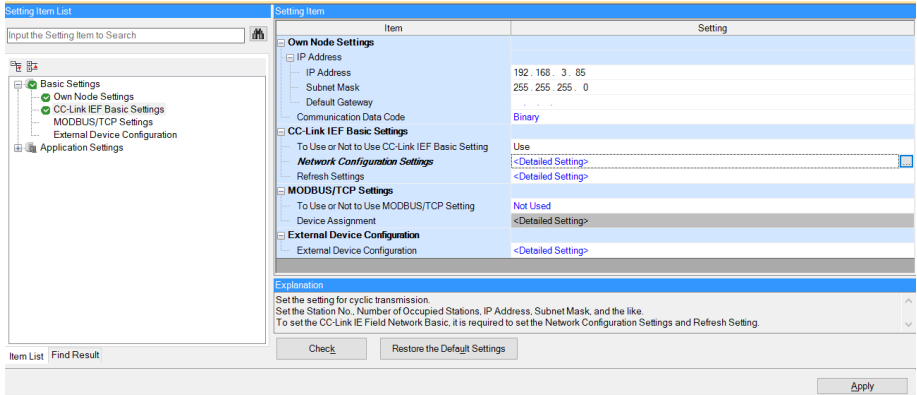

5. Under **CC-Link IEF Basic settings** > **To Use or Not to Use CC-Link IEF Basic Setting** select "Use".

- ▶ The option *Network Configuration Settings* allows you to configure a CC-Link IE Field Basic Master, connected stations, a Network, parameters and many more.
- ▶ Settings under *Refresh Settings* are necessary for the automatic data transfer between Link side and CPU side:

Link Side				CPU Side				
Device Name	Points	Start	End	Target	Device Name	Points	Start	End
RX	256	00000	000FF	Specify Devi	X	256	100	477
RY	256	00000	000FF	Specify Devi	Y	256	100	477
RWr	128	00000	0007F	Specify Devi	R	128	100	227
RWw	128	00000	0007F	Specify Devi	W	128	00100	0017F

6. For applying new changes under **CC-Link IEF Basic settings**, press "apply" in **Module Parameter** > **Ethernet Port**. *Write to PLC* and *PLC reset*

actions are needed. Verify that *Module Parameter* is checked when executing *Write to PLC*.

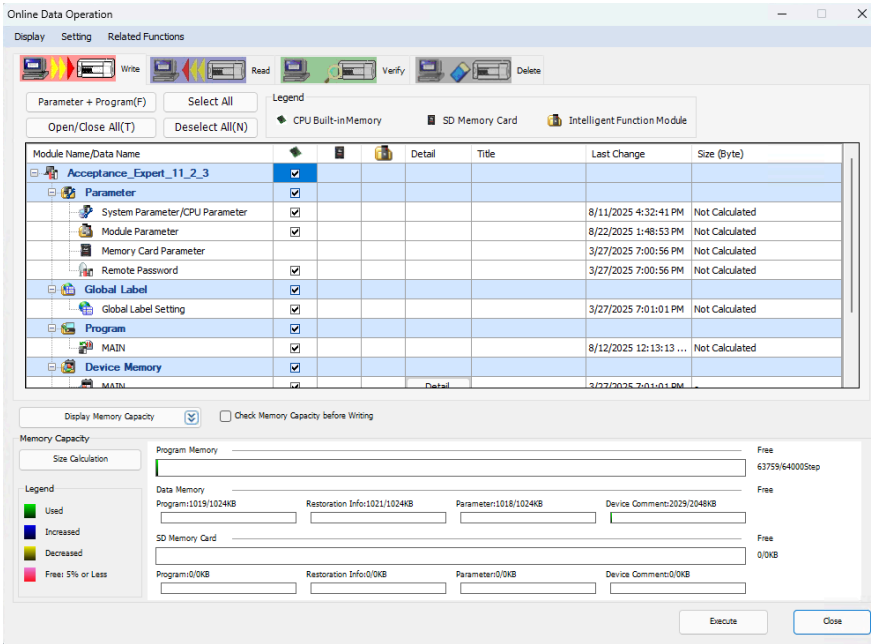

11.3 Parameter processing

Under *Network Configuration Settings*, individual stations can be configured. Perform the following work steps to configure a LioN-X device:

1. Select the LioN-X device from the *Module List*. Alternatively, click the button **Detect Now** for automatic detection of devices.

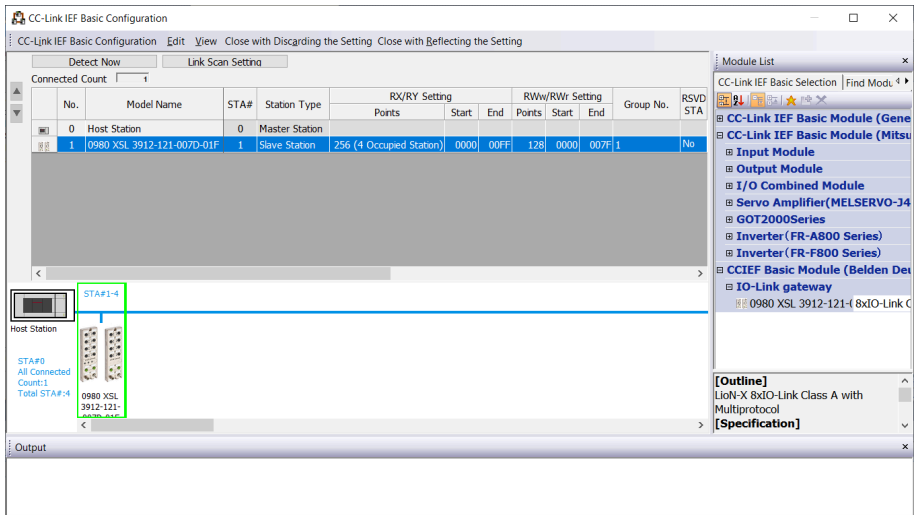

2. Right-click on "Slave Station" and select **Online > Parameter Processing of Slave Station...**

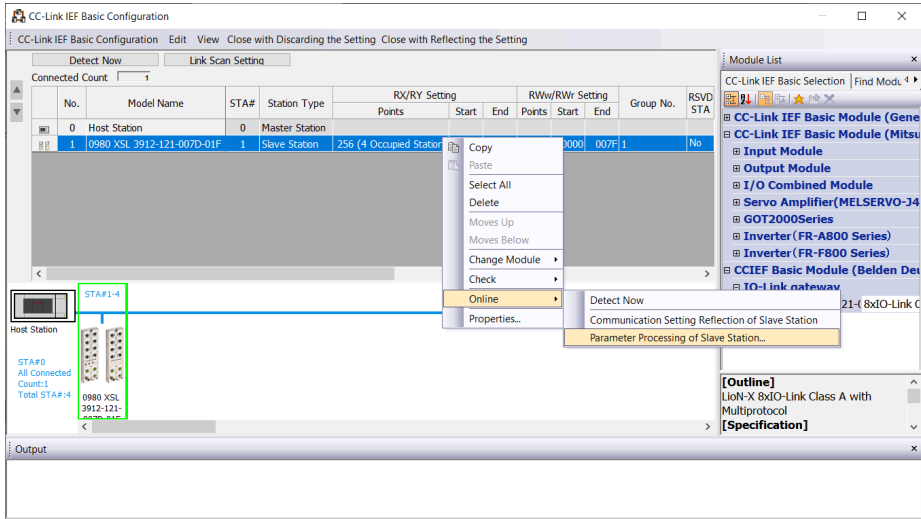

3. In the next window under *Method selection*, choose “Parameter read” or “Parameter write”, depending on which method you want to configure for the LioN-X device. For details on the different parameters please refer to chapter [Configuration CC-Link IE Field Basic](#).

Parameter Processing of Slave Station

Target Module: 0980 XSL 3912-121-007D-01F
Station No.: 1

Method selection: **Parameter read** (selected)
Read parameter from target module.

Parameter Information
Checked parameters are the targets of selected processes.

Select All Cancel All Selections

Name	Initial Value	Unit	Read Value	Unit	Write Value	Unit	Setting Range	Description
General Settings								
<input checked="" type="checkbox"/> GeneralSettings								General Settings
<input type="checkbox"/> Suppress Uaux Diagnosis Mo...	DEVIOL_UL...							
<input type="checkbox"/> Suppress ActuatorDiagnosis ...	0						0 to 1	
<input type="checkbox"/> Suppress US Diagnosis	0						0 to 1	
<input type="checkbox"/> Reserved	0						0 to 1	
<input type="checkbox"/> Output Auto Restart	1						0 to 1	
<input type="checkbox"/> Web Interface Lock	0						0 to 1	
<input type="checkbox"/> Forcing Lock	1						0 to 1	
<input type="checkbox"/> External Configuration Lock	1						0 to 1	

Clear All "Read Value" Clear All "Write Value"

Process Option
There is no option in the selected

- Process is executed to a module of "Target Module Information".
- The device is accessed by using "the current connection destination". Please check if there is any problem with the connection destination.
- For information on items not displayed on the screen, please refer to the Operating Manual.

Import... Export... Execute Close

4. After having adjusted the parameters, click on **Communication Setting Reflection of Slave Station** to apply the changes to the respective module.

12 IloT functionality

The LioN-X variants offer a number of new interfaces and functions for the optimal integration into existing or future IloT (Industrial Internet of Things) networks. The devices continue to work as field bus devices which communicate with and are controlled by a PLC (Programmable Logic Controller).

In addition, the devices offer common IloT interfaces, which enable new communication channels besides the PLC. The communication is performed via IloT-relevant protocols MQTT and OPC UA. With the help of these interfaces not only all information in a LioN-X device can be read. They also enable its configuration and control, if the user wishes. All interfaces can be configured extensively and offer read-only functionality.

All LioN-X variants provide user administration, which is also applicable for accessing and configuring the IloT protocols. This allows you to manage all modification options for the device settings via personalized user authorizations.

All IloT protocols can be used and configured independently of the field bus. It is also possible to use the devices completely without the help of a PLC and control them via IloT protocols.



Attention: When using the IloT functionality, a protected local network environment without direct access to the Internet is recommended.

12.1 MQTT

The MQTT (Message Queueing Telemetry Transport) protocol is an open network protocol for machine-to-machine communication, which provides the transmission of telemetric data messages between devices. The integrated MQTT client allows the device to publish a specific set of information to an MQTT broker.

The publishing of messages can either occur periodically or be triggered manually.

12.1.1 MQTT configuration

In **delivery state**, MQTT functions are **disabled**. The MQTT client can be configured either using the Web interface or directly via a JSON object sent in an HTTP request. For more information see chapter [MQTT configuration - Quick start guide](#) on page 81.

The configuration URL is:

```
http://[ip-address]/w/config/mqtt.json
```

The configuration can also read back as a JSON file:

```
http://[ip-address]/r/config/mqtt.json
```

The configuration is a JSON object. Each JSON member is a configuration element. The object must not contain all elements. Only the provided elements will be changed. The configuration changes apply only after a device restart.

The following configuration elements are available (default values in bold):

Element	Data type	Description	Example data
mqtt-enable	boolean	Master switch for the MQTT client.	true / false
broker	string	IP address of the MQTT Broker	" 192.168.1.1 "
login	string	Username for MQTT Broker	"admin" (Default: null)
password	string	Password for MQTT Broker	"private" (Default: null)
port	number	Broker port	1883
base-topic	string	Base topic	"iomodule_[mac]" (Default: " lionx ")
will-enable	boolean	If true, the device provides a last will message to the broker	true / false
will-topic	string	The topic for the last will message.	(Default: null)
auto-publish	boolean	If true, all enabled domains will be published automatically in the specified interval.	true / false
publish-interval	number	The publish interval in ms if auto-publish is enabled. Minimum is 250 ms.	2000
publish-identity	boolean	If true, all identity domain data will be published	true / false
publish-config	boolean	If true, all config domain data will be published	true / false
publish-status	boolean	If true, all status domain data will be published	true / false
publish-process	boolean	If true, all process domain data will be published	true / false
commands-allowed	boolean	Master switch for MQTT commands. If false, the device will not subscribe to any command topic, even if specific command topics are activated below.	true / false
force-allowed	boolean	If true, the device accepts force commands via MQTT.	true / false
reset-allowed	boolean	If true, the device accepts restart and factory reset commands via MQTT.	true / false
config-allowed	boolean	If true, the device accepts configuration changes via MQTT.	true / false

Element	Data type	Description	Example data
qos	number	Selects the "Quality of Service" status for all published messages.	0 = At most once 1 = At least once 2 = Exactly once

Table 13: MQTT configuration

MQTT response:

The resulting response is a JSON object with a "status" field. Status should be "0" if no error occurred and "-1" if there is an error.

In case of an error, the response contains an error array.

The error array contains an error object for each error occurred. The object consists of a field "Element" which names the config element which caused the error, and a field "Message" for the error message.

- ▶ A malformed JSON object produces an error.
- ▶ Not existing parameters produce an error.
- ▶ Parameters with a wrong data type produce an error.

It is not allowed to write all available parameters at once. You may write only one or a limited number of parameters.

Examples:

```
{ "status": -1, "error": [{ "Element": "publish-interval", "Message": "Integer
  expected" }] }

{ "status": 0 }

{ "status": -1, "error": [{ "Element": "root", "Message": "Not a JSON
  object" }] }
```

For more information see chapter [MQTT topics](#) on page 66.

12.1.2 MQTT topics

MQTT mainly relates to topics. All messages are attached to a topic which adds context to the message itself. Topics may consist of a string and they are allowed to contain slashes (/). In topic filters, there also wildcard symbols like e.g. (#) allowed.

12.1.2.1 Base topic

For all LioN-X variants there is a configurable Base topic which is the prefix for all topics. The Base topic can be chosen freely by the user. The Base topic can also contain selected variables as shown in [Table 14: Base topic variables](#) on page 66.

Variables in the Base topic have to be written in brackets ("["]"). The following variables are possible:

Variable	Description
mac	The MAC address of the device
name	The name of the device
order	The ordering number of the device
serial	The serial number of the device
ip0 ip1 ip2 ip3	IP address octets

Table 14: Base topic variables

Example:

The Base topic "io_[mac]" translates to "io_A3B6F3F0F2F1".

All data is organized in domains. The domain name is the first level in the topic after the Base topic. Note the following notation:

Base-Topic/domain/....

There are the following domains:

Domain name	Definition	Example content
identity	All fixed data which is defined by the used hardware and which cannot be changed by configuration or at runtime.	Device name, ordering number, MAC address, port types, port capabilities and more.
config	Configuration data which is commonly loaded once at startup, mostly by a PLC.	IP address, port modes, input logic, failsafe values and more.
status	All (non-process) data which changes quite often in normal operation.	Bus state, diagnostic information, Device status and data.
process	All process data which is produced and consumed by the device itself or by attached devices.	Digital inputs, digital outputs, cyclic data.

Table 15: Data domains

There is often one topic used for all gateway related information and topics for each port. All identity topics are published just once at start-up, because this information should never change. All other topics are published either in a fixed interval or just triggered manually, according to the configuration.

Topic	Content examples	Total publish count	Publish interval
[base-topic]/identity/gateway	Name, ordering number, MAC, vendor, I&M etc.	1	Startup
[base-topic]/identity/port/n	Port name, port type	8	Startup
[base-topic]/config/gateway	Configuration parameters, ip address etc.	1	Interval
[base-topic]/config/port/n	Port mode, data storage, mapping, direction	8	Interval
[base-topic]/status/gateway	Bus state, device diagnosis, master events	1	Interval
[base-topic]/status/port/n	Port or channel diagnosis, state	8	Interval
[base-topic]/process/gateway	All Digital IN/OUT	1	Interval

Table 16: Data model

An MQTT client which wants to subscribe to one or more of these topics can also use wildcards.

Full topic	Description
[base-topic]/identity/gateway	Receive only identity objects for the gateway
[base-topic]/identity/#	Receive all data related to the identity domain
[base-topic]/status/port/5	Receive only status information for port number 5
[base-topic]/+/port/2	Receive information of all domains for port number 2
[base-topic]/config/#	Receive config data for the gateway and all ports.

Table 17: Use case examples

12.1.2.2 Publish topic

Overview of all publish JSON data for the defined topics:

Identity/gateway	
Key	Data type
product_name	json_string
ordering_number	json_string
device_type	json_string
serial_number	json_string
mac_address	json_string
production_date	json_string
fw_version	json_string
hw_version	json_string
family	json_string
location	json_string
country	json_string
fax	json_string
vendor_name	json_string
vendor_address	json_string
vendor_phone	json_string
vendor_email	json_string
vendor_tech_support	json_string
vendor_url	json_string

Table 18: Identity/gateway

Config/gateway				
Key	Data type	Range	Default value	Remarks
fieldbus_protocol	json_string	PROFINET EtherNet/IP EtherCAT® Modbus TCP CC-Link IE Field Basic		
network_configuration	json_string	PROFINET: ▶ DCP ▶ Manual EtherNet/IP: ▶ Manual ▶ Rotary ▶ DHCP EtherCAT®: ▶ Manual Modbus TCP: ▶ Manual ▶ DHCP ▶ Rotary CC-Link IE Field Basic: ▶ Manual ▶ Rotary		
rotary_switches	json_integer	0 .. 999		
ip_address	json_string		192.168.1.1	
subnet_mask	json_string		255.255.255.0	
report_ul_alarm	json_boolean	true / false	true	
report_do_fault_without_ul	json_boolean	true / false	false	
force_mode_lock	json_boolean	true / false	false	
web_interface_lock	json_boolean	true / false	false	
fast_startup	json_boolean	true / false	false	PROFINET and EIP only

Config/gateway				
Key	Data type	Range	Default value	Remarks
dcu_autostart	json_boolean	true / false	false	

Table 19: Config/gateway

Status/gateway				
Key	Data type	Range	Default value	Remarks
protocol	json_string	PROFINET: ► UNKNOWN ► OFFLINE ► STOP ► IDLE ► OPERATE EtherNet/IP: ► CONNECTED ► DISCONNECTED EtherCAT®: ► PREOP ► SAFEOP ► OP ► INIT ► UNKNOWN Modbus TCP: ► No Connections ► Connected CC-Link IE Field Basic: ► ON ► STOP ► DISCONNECTED ► ERROR		
system_voltage_fault	json_boolean	true / false		
actuator_voltage_fault	json_boolean	true / false		
internal_module_error	json_boolean	true / false		
simulation_active_diag	json_boolean	true / false		
us_voltage	json_integer	0 .. 32		in Volts
ul_voltage	json_integer	0 .. 32		in Volts
forcemode_enabled	json_boolean	true / false		

Table 20: Status/gateway

Process/gateway				
Key	Data type	Range	Default value	Remarks
Input_data	json_integer[]			
output_data	json_integer[]			

Table 21: Process/gateway

Identity/port/1 .. 8				
Key	Data type	Range	Default value	Remarks
port	json_integer	1 .. 8		
type	json_string	Digital Input DIO Digital Output DIO Pin 4 Only DI Pin 4 Only DO Pin 4 Only Not available Unknown		
max_output_power_cha	json_string	2.0_mA 0.5_mA		
max_output_power_chb	json_string	2.0_mA 0.5_mA		
channel_cha	json_string	Digital Input Digital Output DIO Digital Input/Output Not available Unknown		
channel_chb	json_string	Digital Input Digital Output DIO Digital Input/Output Not available Unknown		

Table 22: Identity/port/1 .. 8

Config/port/1 .. 8				
Key	Data type	Range	Default value	Remarks
port	json_integer	1 .. 8		
direction_cha	json_string	Output Input Inactive DIO Unknown		
direction_chb	json_string	Output Input Inactive DIO Unknown		
restart_mode_cha	json_string	Manual Auto		
restart_mode_chb	json_string	Manual Auto		
input_polarity_cha	json_string	NO NC		
input_polarity_chb	json_string	NO NC		
input_filter_cha	json_integer			ms
input_filter_chb	json_integer			ms
failsafe_cha	json_string	set_low set_high hold_last	set_low	
failsafe_chb	json_string	set_low set_high hold_last	set_low	
surveillance_timeout_cha	json_integer	0 .. 255	80	
surveillance_timeout_chb	json_integer	0 .. 255	80	

Table 23: Config/port/1 .. 8

Status/port/1 .. 8				
Key	Data type	Range	Default value	Remarks
port	json_integer	1 .. 8		
physical_state_cha	json_integer	0 .. 1		
physical_state_chb	json_integer	0 .. 1		
actuator_short_circuit_cha	json_boolean	true / false		
actuator_short_circuit_chb	json_boolean	true / false		
sensor_short_circuit	json_boolean	true / false		

Table 24: Status/port/1 .. 8

12.1.2.3 Command topic (MQTT Subscribe)

The main purpose of MQTT is to publish data from the device to a broker. This data can then be received by any subscriber who is interested in this data. But also the other way round is possible. The device can subscribe to a topic on the broker and is then able to receive data. This data can contain configuration or forcing data. This allows the user to fully control a device via MQTT only, without using other ways of communication like Web or REST.

If the configuration allows commands in general, the device subscribes to special Command topics on which it can receive commands from other MQTT clients. The Command topic is based upon the Base topic. It always has the following form:

```
[base-topic]/command
```

After the Command topic, there are fixed topics for different writeable objects. The data format of the MQTT payload is always JSON. It is possible to set only a subset of the possible objects and fields.

[...]/forcing

Use the Command topic `[base-topic]/command/forcing` for *Force object* data. The *Force object* can contain any of the following properties:

Property	Data type	Example values	Remarks
forcemode	boolean	true / false	Forcing Authority: on/off
digital	array (Table 26: Force object: Digital on page 78)		

Table 25: Force object properties

For the *Force object* property *digital*, there are several value specifications arrayed:

Property	Data type	Example values	Remarks
port	integer	1, 2, 5	
channel	string	"a", "b"	
force_dir	string	"out", "in", "clear"	
force_value	integer	0, 1	

Table 26: Force object: Digital

[...]/config

Use the Command topic `[base-topic]/command/config` for *Config object* data. The *Config object* can contain any of the following properties:

Property	Data type	Example values	Remarks
portmode	array (Table 28: Config object: Portmode on page 79)		
ip_address	string	"192.168.1.5"	
subnet_mask	string	"255.255.255.0"	
gateway	string	"192.168.1.100"	

Table 27: Config object properties

For the *Config object* property `portmode`, there are several value specifications arrayed:

Property	Data type	Example values	Remarks
port	integer	2	
channelA*	string	"dio", "di", "do", "off"	
channelB*	string	"dio", "di", "do", "off"	
inlogicA	string	"no", "nc"	
inlogicB	string	"no", "nc"	
filterA	integer	3	input filter in ms
filterB	integer	3	input filter in ms
autorestartA	boolean		
autorestartB	boolean		

Table 28: Config object: Portmode

*channelA = Pin 4, channelB = Pin 2

[...]/reset

Use the Command topic `[base-topic]/command/reset` for *Reset object* data about restart and factory reset issues. The *Reset object* can contain any of the following properties:

Property	Data type	Example values	Remarks
factory_reset	boolean	true / false	
system_reset	boolean	true / false	

Table 29: Reset object properties

[...]/publish

Use the Command topic `[base-topic]/command/publish` for *Publish object* data.

Trigger publish of all topics manually (can be used when auto publish is off or long interval is set).

12.1.3 MQTT configuration - Quick start guide



Attention: Belden Deutschland GmbH is not responsible for any content of the referenced Web pages and provides no warranty for any functionality of the named third party software.

12.1.3.1 MQTT configuration via JSON

1. Depending on your application case, download and install *Insomnia* or a comparable application: <https://insomnia.rest/download/>

2. Configure MQTT:

POST: [IP-address]/w/config/mqtt.json

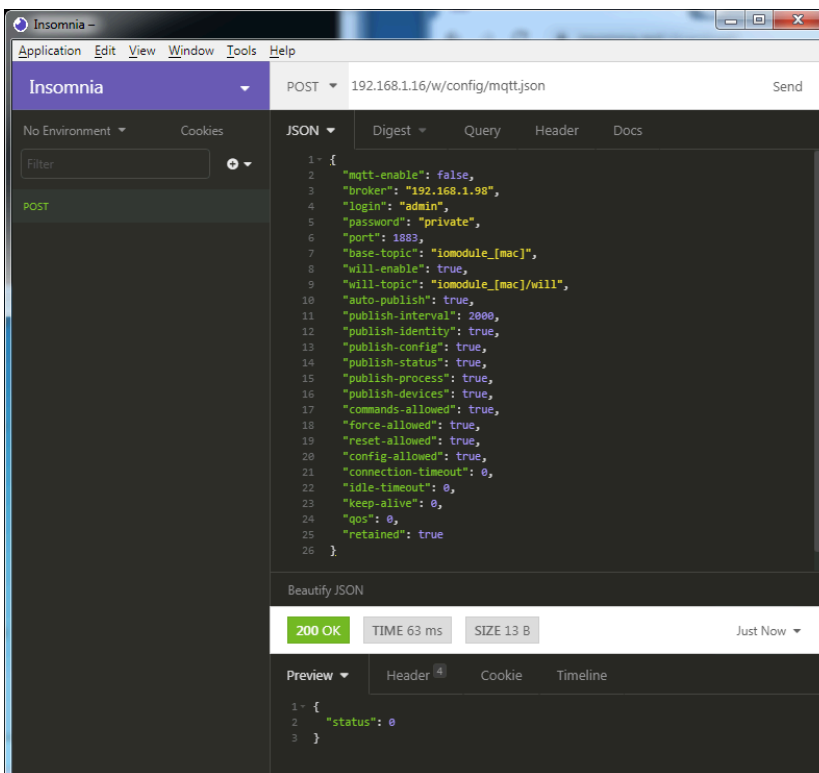

3. Read MQTT:

GET: [IP-address]/r/config/mqtt.json

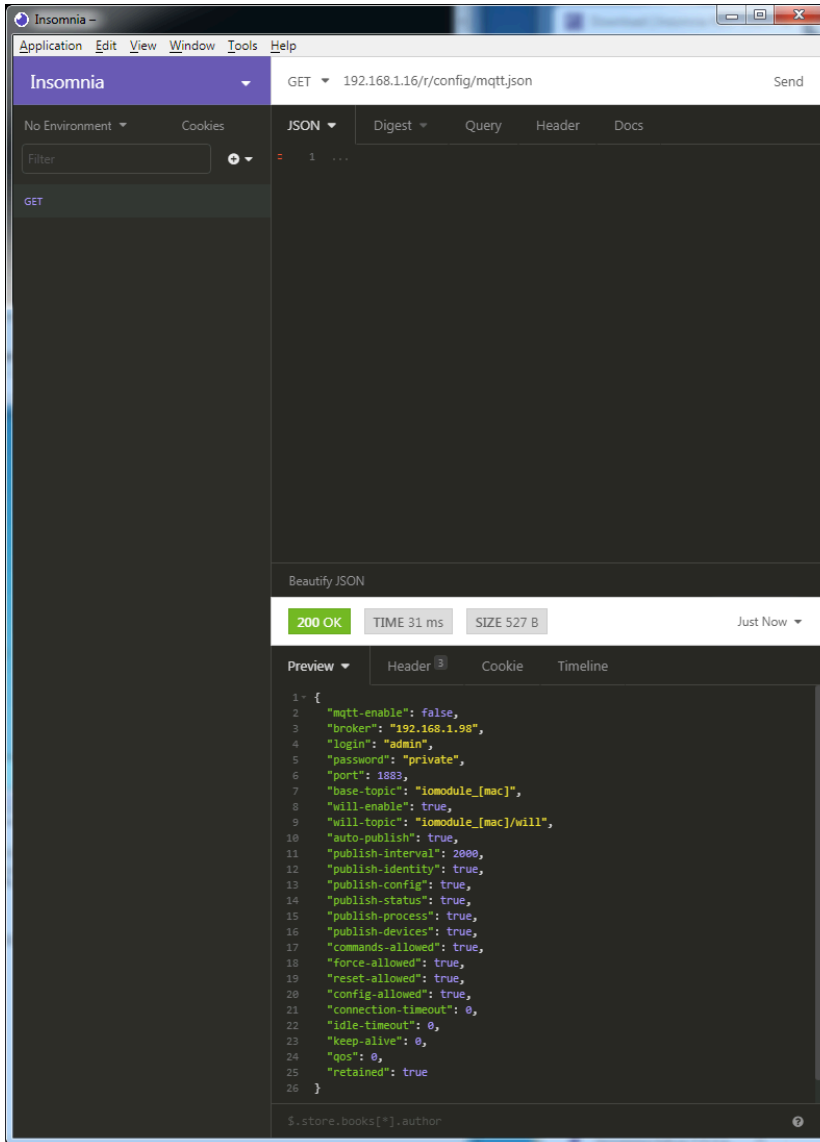

12.2 OPC UA

OPC Unified Architecture (OPC UA) is a platform-independent standard with a service-oriented architecture for communication in and with industrial automation systems.

The OPC UA standard is based on the client-server principle and lets machines and devices, regardless of any preferred field bus, communicate horizontally among each other as well as vertically to the ERP system or the cloud. LioN-X provides an OPC UA server on field device level, with which an OPC UA client can connect for information exchange secure in transmission.

12.2.1 OPC UA configuration

In **delivery state**, OPC UA functions are **disabled**. The OPC UA Server can be configured either using the Web interface or directly via a JSON Object sent in an HTTP request.

The configuration URL is:

```
http://[ip-address]/w/config/opcu.json
```

The configuration can also read back as a JSON file:

```
http://[ip-address]/r/config/opcu.json
```

The configuration is a JSON object. Each JSON member is a configuration element. The object must not contain all elements. Only the provided elements will be changed. All configuration changed applies only after a device restart.

Tree overview of OPC UA objects:

- Gateway
 - Identity
 - Name
 - MAC
 - Ordering Number
 - Production Date
 - Capabilities
 - Firmware Versions
 - Status (r)
 - US present
 - UL present
 - US diag
 - UL diag
 - US Voltage
 - UL Voltage
 - IME
 - Forcemode Diag
 - Rotary positions
 - Forcing (r)
 - Forcing active
 - Forcing client
 - OwnForcing flag
 - Config (rw)
 - IP Config
 - suppressActuatorDiagWithoutUL
 - suppressUSDiag
 - suppressULDiag
 - quickConnect
 - Process (r)
 - Digital Inputs
 - Digital Outputs
 - Producing Data (to PLC)
 - Consuming Data (from PLC)
 - Valid masks
 - Commands (w)
 - Restart
 - Factory Reset
 - Forcemode enable
- Ports
 - Port *n* ("X1"- "X8")
 - Identity
 - Port Name
 - Port Type
 - Channel *m* ("Pin 4" / "Pin 2")
 - Identity (r)
 - Channel Name
 - Channel Type
 - MaxOutputCurrent
 - Status (r)
 - Actuator Diag
 - Actuator Voltage
 - Actuator Current
 - Channel Failsafe flag
 - Config (rw)
 - Surveillance Timeout
 - Failsafe Config
 - Channel Direction
 - Channel Current Limit
 - Auto Restart
 - InputFilterTime
 - InputLogic
 - InputLogic
 - Process (r)
 - Output Bit
 - Input Bit
 - Consuming Bit
 - Producing Bit
 - Forcing (rw)
 - Force channel on/off
 - Force value on/off
 - Simulate channel
 - Simulate value
 - Status (r)
 - Pin 1 Short Circuit Dia

All configuration elements are optional and do not need a specific order. Not every element is required to be sent. This means that only configuration changes will be taken over.

Optional: The configuration parameters of OPC UA can be set directly via the Web interface. It is possible to download the Web interface for sharing with other devices.

Response:

The resulting response is a JSON object with a status field. Status should be "0" if no error occurred and "-1" if there is an error.

In case of an error, the response contains an error array.

The error array contains an error object for each error occurred. The object consists of a field "Element" which names the config element which caused the error, and a field "Message" for the error message.

Examples:

```
{ "status": -1, "error": [ { "Element": "upcua-enable", "Message": "Boolean expected" } ] }  
  
{ "status": 0 }  
  
{ "status": -1, "error": [ { "Element": "root", "Message": "Not a JSON object" } ] }
```

12.2.1.1 Gateway objects

Identity

Name	Data type	Example
Device Name	UA_STRING	
Device ID	UA_STRING	
MAC address	UA_STRING	
Ordering Number	UA_STRING	
Serial Number	UA_STRING	
Production Date	UA_STRING	
Hardware Version	UA_STRING	
App Firmware Version	UA_STRING	
Fieldbus Firmware Version	UA_STRING	
IO Firmware Version	UA_STRING	
Running Fieldbus	UA_STRING	
Forcemode supported	UA_BOOLEAN	Forcing supported by module variant

Status (read)

Name	Data type	Unit	Example
US present	UA_BOOLEAN		
UL present	UA_BOOLEAN		
US diagnosis	UA_BOOLEAN		
UL diagnosis	UA_BOOLEAN		
Internal Module Error diag	UA_BOOLEAN		

Name	Data type	Unit	Example
Forcemode diag	UA_BOOLEAN		
US voltage	UA_DOUBLE	V	23.2
UL voltage	UA_DOUBLE	V	22.9
Rotary position	UA_UINT16		343

Forcing (read)

Name	Data type	Example
Forcing active	UA_BOOLEAN	
Forcing client	UA_STRING	if forcemode is not active, string is empty
Own Forcing	UA_BOOLEAN	Indicates if OPC UA is currently forcing
Forcing possible	UA_BOOLEAN	true if forcing by OPC UA is possible
Forcemode lock	UA_BOOLEAN	Forcing locked by PLC

Config (read + write)

Name	Data type	Example
IP address	UA_STRING	
Subnet Mask	UA_STRING	
Default Gateway IP	UA_STRING	
Suppress US diag	UA_BOOLEAN	
Suppress UL diag	UA_BOOLEAN	
Suppress Actuator Diag w/o UL	UA_BOOLEAN	
QuickConnect	UA_BOOLEAN	

Process (read)

Name	Data type	Example
Input Data	UA_UINT16	ioInput for all channels
Output Data	UA_UINT16	ioOutput for all channels
Consuming Data	UA_UINT16	Data from the PLC to the device
Producing Data	UA_UINT16	Data from the device to the PLC

Commands (write)

Name	Arguments	Return	Example
Restart	void	UA_INT32	
Factory reset	void	UA_INT32	
Forcemode enable	void	UA_INT32	
Forcemode disable	void	UA_INT32	

12.2.1.2 Ports objects

Identity

Name	Data type	Example
Name	UA_STRING	"X1"
Type	UA_STRING	"DIO"

Channel *m* ("Pin 4" / "Pin 2")

See details in [Channel objects](#) on page 90.

Status (read)

Name	Data type	Unit	Example
Sensor Diag	UA_BOOLEAN		

12.2.1.3 Channel objects**Identity (read)**

Name	Data type	Unit	Example
Name	UA_STRING		"X1A"
Type	UA_STRING		"DIO"
MaxOutputCurrent	UA_INT16	mA	1300

Status (read)

Name	Data type	Unit	Example
Actuator Diag	UA_BOOL		
Channel Failsafe	UA_BOOL		

Config (read + write)

Name	Data type	Unit	Example / Remarks
Surveillance Timeout	UA_UINT8	ms	80 ms
Failsafe Config	UA_ENUMERATION		Low Hi Hold Last
Channel Direction	UA_ENUMERATION		DIO Input Output Inactive

Name	Data type	Unit	Example / Remarks
Auto Restart	UA_BOOL		
InputFilterTime	UA_UINT8	ms	3ms
InputLogic	UA_ENUMERATION		NO NC

Process (read)

Name	Data type	Example / Remarks
Output	UA_BOOLEAN	Output type channels only.
Input	UA_BOOLEAN	Input type channels only.
Consuming	UA_BOOLEAN	
Producing	UA_BOOLEAN	

Forcing (read + write)

Name	Data type	Example / Remarks
Force channel	UA_BOOLEAN	Enable forcing with the current force value or disable forcing for this channel. Output type channels only.
Force value	UA_BOOLEAN	When changed by the user it will start forcing with the new value if forcing is enabled for opcua. Output type channels only.
Simulate channel	UA_BOOLEAN	Enable simulation with the current force value or disable simulation for this channel. Input type channels only.

Name	Data type	Example / Remarks
Simulate value	UA_BOOLEAN	When changed by the user it will start simulation with the new value if forcing is enabled for opcua. Input type channels only.

12.2.2 OPC UA address space

OPC UA provides different services on the LioN-X devices with which a client can navigate through the hierarchy of the address space and read or write variables. In addition, the client can monitor up to 10 attributes from the address space for value changes.

A connection to an OPC UA server is established via the endpoint URL:

```
opc.tcp://[ip-address]:[port]
```

Various device data such as MAC address, device settings, diagnostics or status information can be read via *Identity objects*, *Config objects*, *Status objects* and *Process objects*.

Command objects can be read and written. This makes it possible, for example, to transfer new network parameters to the device, to use Force Mode or to reset the entire device to its factory settings.

12.2.3 OPC UA configuration - Quick start guide



Attention: Belden Deutschland GmbH is not responsible for any content of the referenced Web pages and provides no warranty for any functionality of the named third party software.

12.2.3.1 OPC UA configuration via JSON

1. Depending on your application case, download and install *Insomnia* or a comparable application: <https://insomnia.rest/download/>

2. Configure OPC UA:

POST: [IP-address] /w/config/opcuajson

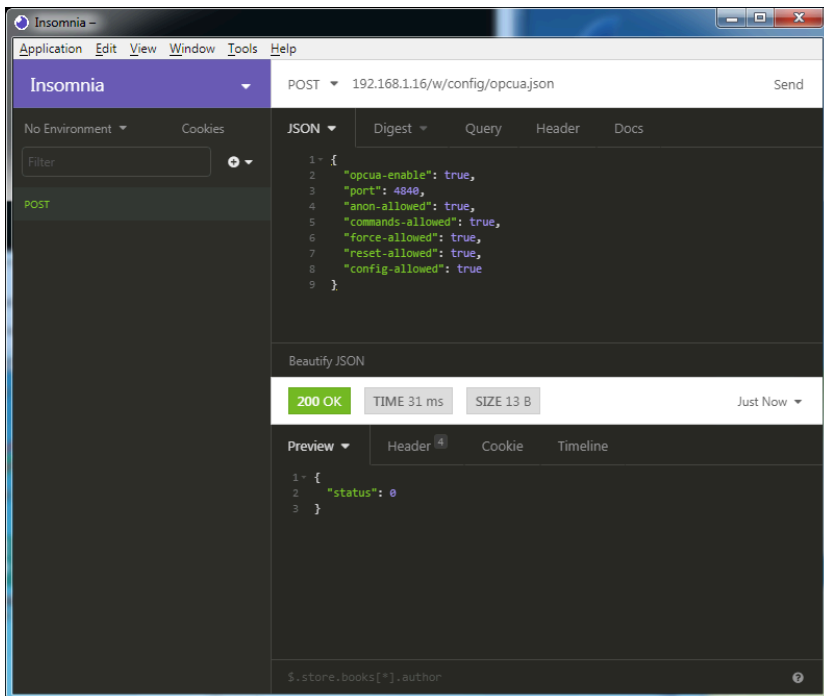

3. Read OPC UA:

GET: [IP-address]/r/config/opcuajson

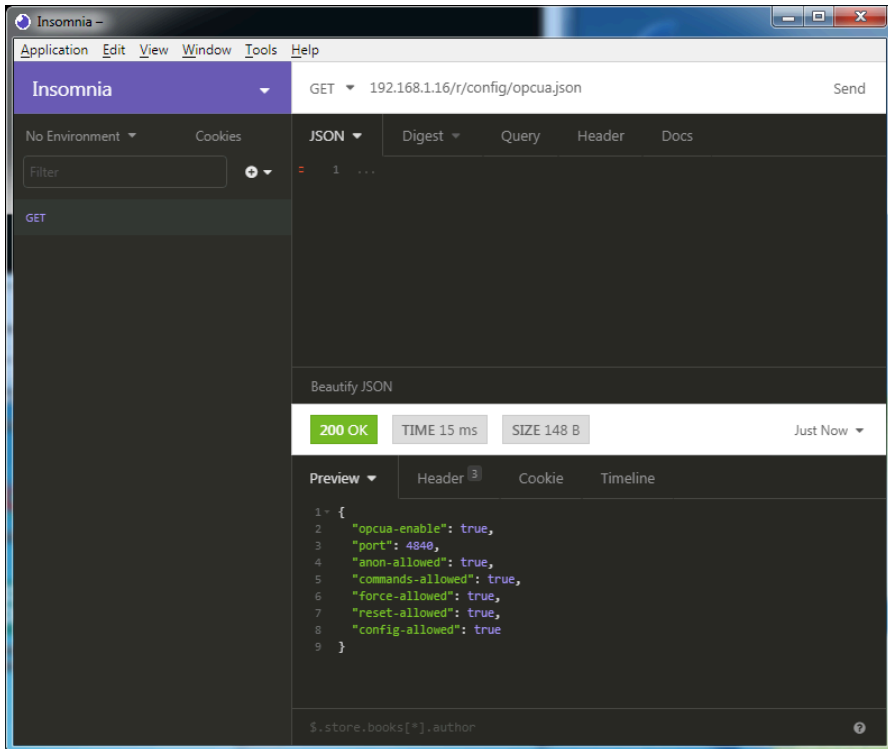

12.3 REST API

The Representational State Transfer – Application Programming Interface (REST API) is a programmable interface which uses HTTP requests to GET and POST data. This enables the access to detailed device information.

For all LioN-X variants, the REST API can be used to read the device status. For the LioN-X multi-protocol variants, the REST API can also be used to write configuration and forcing data.

The customized Belden REST API is described in the following chapters.

12.3.1 Standard device information

Request method:	http GET
Request URL:	<ip>/info.json
Parameters	n.a.
Response format	JSON

The goal of the "Standard device information" request is to get a complete snapshot of the current device status. The format is JSON.

12.3.2 Structure

Name	Data type	Description	Example
name	string	Device name	0980 XLC 3900-121-007D-01F
order-id	string	Ordering number	935715001
fw-version	string	Firmware version	V.11.2.0.0 - 08.08.2024
hw-version	string	Hardware version	V.1.00
mac	string	MAC address of the device	3C B9 A6 F3 F6 05
bus	number	0 = No connection 1 = Connection with PLC	1
failsafe	number	0 = Normal operation 1 = Outputs are in failsafe	0
ip	string	IP address of the device	
snMask	string	Subnet Mask	
gw	string	Default gateway	
rotarys	array of numbers (3)	Current position of the rotary switches: Array element 0 = x1 Array element 1 = x10 Array element 2 = x100	
ulPresent	boolean	True, if there is a UL voltage supply detected within valid range	
usVoltage_mv	number	US voltage supply in mV	
ulVoltage_mv	number	UL voltage supply in mV (only available for devices with UL supply)	
inputs	array of numbers (2)	Real state of digital inputs. Element 0 = 1 Byte: Port X1 Channel A to Port X4 Channel B Element 0 = 1 Byte: Port X5 Channel A to Port X8 Channel B	[128,3]
output	array of numbers (2)	Real State of digital outputs. Element 0 =1 Byte: Port X1 Channel A to port X4 Channel B Element 0 = 1 Byte: Port X5 Channel A to port X8 Channel B	[55,8]

Name	Data type	Description	Example
consuming	array of numbers (2)	Cyclic data from PLC to device	
producing	array of numbers (2)	Cyclic data from device to PLC	
diag	array of numbers (4)	Diagnostic information	<p>Element 0 = 1 Byte: Bit 7: Internal module error (IME) Bit 6: Forcemode active Bit 3: Actuator short Bit 2: Sensor short Bit 1: U_L fault Bit 0: U_S fault</p> <p>Element 1 = 1 Byte: Sensor short circuit ports X1 .. X8.</p> <p>Element 2 = 1 Byte: Actuator short circuit ports X1 Channel A to X4 Channel B</p> <p>Element 3 = 1 Byte: Actuator short circuit ports X5 Channel A to X8 Channel B</p>
fieldbus	FIELDBUS Object		
FIELDBUS Object			
fieldbus_name	string	Currently used fieldbus	
state	number	Fieldbus state	
state_text	number	Textual representation of fieldbus state: 0 = Unknown 1 = Bus disconnected 2 = Preop 3 = Connected 4 = Error 5 = Stateless	
forcing	FORCING Object	Information about the forcing state of the device	

Name	Data type	Description	Example
channels	Array of CHANNEL (16)	Basic information about all input/output channels	
CHANNEL Object			
name	string	Name of channel	
type	number	Hardware channel type as number: 0 = DIO 1 = Input 2 = Output 3 = Input/Output 4 = Channel not available 5 = Channel not available 6 = Channel not available 7 = Channel not available 8 = Channel not available	
type_text	string	Textual representation of the channel type	
config	number	Current configuration of the channel: 0 = DIO 1 = Input 2 = Output 3 = Channel not available 4 = Deactivated 5 = Channel not available	
config_text	string	Textual representation of the current config	
inputState	boolean	Input data (producing data) bit to the PLC	
outputState	boolean	Output data bit to the physical output pin	
forced	boolean	True, if the output pin of this channel is forced	
simulated	boolean	True, if the input value to the PLC of this channel is simulated	
actuatorDiag	boolean	True, if the output is in short circuit / overload condition	
sensorDiag	boolean	True, if the sensor supply (Pin 1) is in short circuit / overload condition	

Name	Data type	Description	Example
maxOutputCurrent_mA	number	Maximum output current of the output in mA	
current_mA	number	Measured current of the output in mA (if current measurement is available)	
voltage_mV	number	Measured voltage of this output in mV (if voltage measurement is available)	
PORT Object			
port_type	string	Textual representation of the port type	
ds_fault	number	Data storage error number	
ds_fault_text	string	Textual data storage error.	
diag	array of DIAG (n)	Array of port related events	
DIAG Object			
error	number	Error code	
source	string	Source of the current error.	"device" "master"
message	string	Error message	"Supply Voltage fault"
FORCING Object			
forcingActive	boolean	Force mode is currently active	
forcingPossible	boolean	True, if forcing is possible and force mode can be activated	
AuthPossible	boolean	True, if the JSON Interface can obtain forcing authorization	
ownForcing	boolean	True, if forcing is performed by REST API at the moment	
currentClient	string	Current forcing client identifier	
digitalOutForced	array of numbers (2)	The force values of all 16 digital output channels.	
digitalOutMask	array of numbers (2)	The forcing mask of all 16 digital output channels.	
digitalInForced	array of numbers (2)	The force values of all 16 digital input channels.	
digitalInMask	array of numbers (2)	The forcing mask of all 16 digital input channels.	

12.3.3 Configuration and forcing

Method:	POST
URL:	<ip>/w/force.json
Parameters:	None
Post-Body:	JSON Object

Property	Data type	Example values	Description
forcemode	boolean	true / false	Forcing authority on/off
portmode	array (Port mode object)		
digital	array (Digital object)		

Table 30: Root object

Property	Data type	Example values	Remarks
port	integer	0..7	
channel	string	"a","b"	optional default is "a"
direction	string	"dio","di","do", "off"	
inlogica	string	"no","nc"	
inlogicb	string	"no","nc"	

Table 31: Port mode object

Property	Data type	Example values	Remarks
port	integer	0..7	
channel	string	"a","b"	
force_dir	string	"phys_out","plc_in","clear"	optional default is "phys_out"
force_value	integer	0,1	

Table 32: Digital object

12.4 CoAP server

The **Constrained Application Protocol (CoAP)** is a specialized Internet application protocol for constrained networks such as lossy or low power networks. CoAP is useful especially in M2M (Machine to Machine) communication and can be used to translate simplified HTTP requests of low speed networks.

CoAP is based on the Server-Client principle and a service layer protocol that lets nodes and machines communicate with each other. The LioN-X multi-protocol variants provide CoAP server functionalities via a REST API interface over UDP.

12.4.1 CoAP configuration

In delivery state, CoAP functions are *disabled*. The CoAP server can be configured either using the Web interface or directly via a JSON object sent in an HTTP/HTTPS request. For more information see chapter [CoAP configuration - Quick start guide](#) on page 105.

The configuration URL is:

```
http://[ip-address]/w/config/coapd.json
```

The configuration can also read back as a JSON file:

```
http://[ip-address]/r/config/coapd.json
```

The configuration is a JSON object. Each JSON member is a configuration element. The object must not contain all elements. Only the provided elements will be changed. The configuration changes apply only after a device restart.

The following configuration elements are available (default values in bold):

Element	Data type	Description	Example data
enable	boolean	Master switch for the CoAP server	true / false
port	integer (0 to 65535)	Port of the CoAP server	5683

Table 33: CoAP configuration

CoAP response:

The resulting response is a JSON object with a "status" field. Status should be "0" if no error occurred, and "-1" if there is an error.

In case of an error, the response contains an error array.

The error array contains an error object for each error occurred. The object consists of a field "Element" which names the config element that caused the error, and of a field "Message" for the error message.

Examples:

```
{ "status": -1, "error": [ { "Element": "upcua-enable", "Message": "Boolean
expected" } ] }

{ "status": 0 }

{ "status": -1, "error": [ { "Element": "root", "Message": "Not a JSON
object" } ] }
```

12.4.2 REST API access via CoAP

A connection to the CoAP server running on the LioN-X multi-protocol variants can be established via the following URL:

```
coap://[ip-address]:[port]/[api]
```

For LioN-X, the following REST API Requests (JSON format) can be accessed via a CoAP endpoint:

Type	API	Note
GET	/r/status.lr	
GET	/r/system.lr	
GET	/info.json"	
GET	/r/config/net.json	
GET	/r/config/mqtt.json	
GET	/r/config/opcu.json	
GET	/r/config/coapd.json	
GET	/r/config/syslog.json	
GET	/contact.json	
GET	/fwup_status	

Table 34: REST API access via CoAP

12.4.3 CoAP configuration - Quick start guide



Attention: Belden Deutschland GmbH is not responsible for any content of the referenced Web pages and provides no warranty for any functionality of the named third party software.

12.4.3.1 CoAP configuration via JSON

1. Depending on your application case, download and install *Insomnia* or a comparable application: <https://insomnia.rest/download/>

2. Configure CoAP:

POST: [IP-address] /w/config/coapd.json

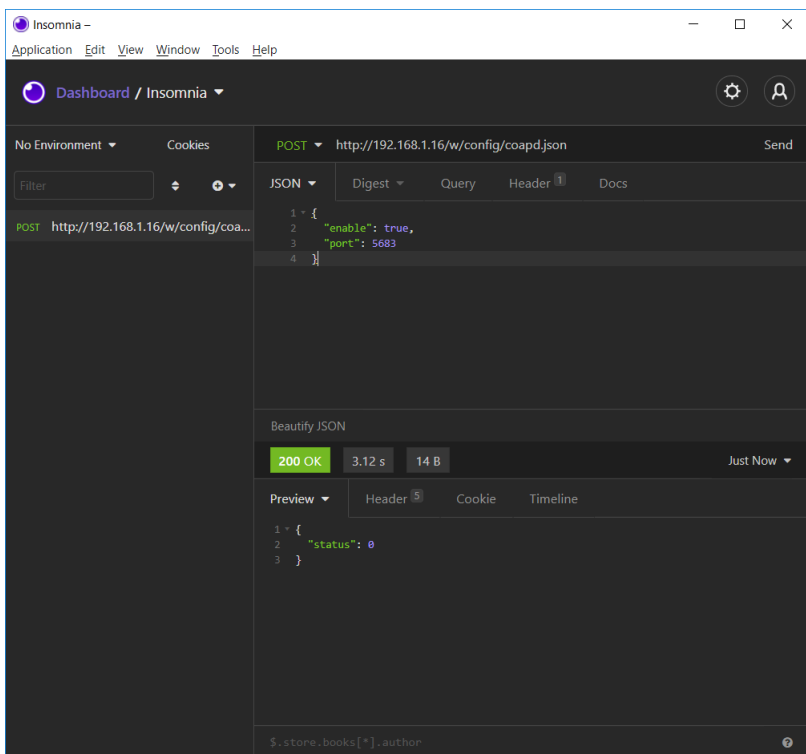

3. Read CoAP configuration:

GET: [IP-address]/r/config/coapd.json

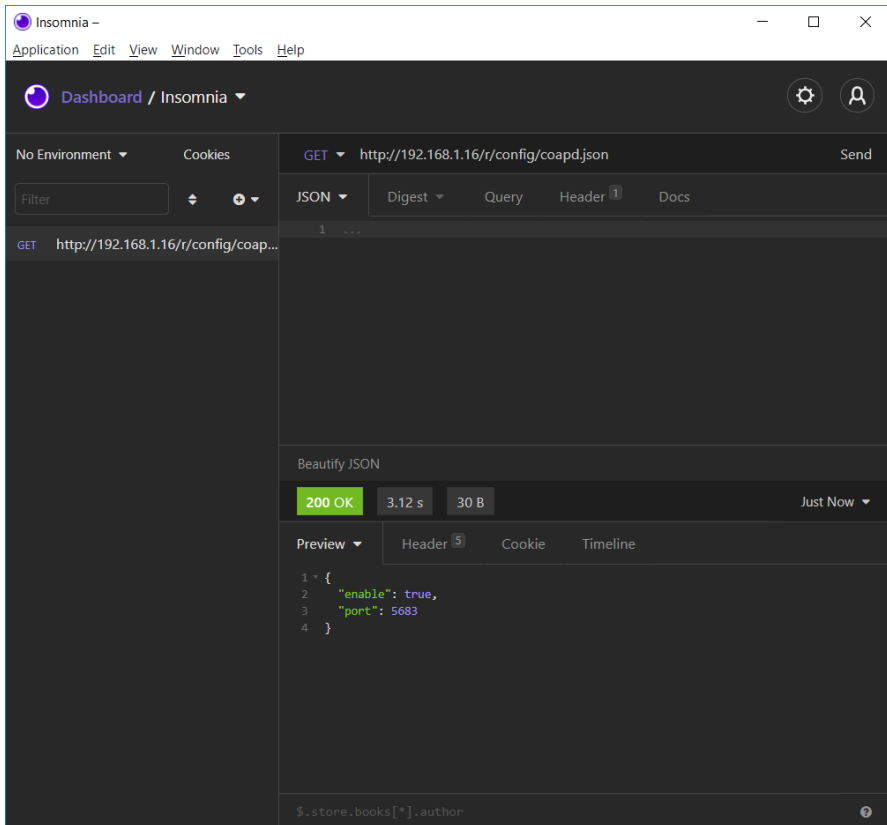

The screenshot shows the Insomnia REST client interface. The top bar displays the application name 'Insomnia' and standard window controls. Below the menu bar, the 'Dashboard / Insomnia' view is active. The main workspace is divided into several sections:

- Environment:** 'No Environment' is selected.
- Request:** A GET request is defined for the URL 'http://192.168.1.16/r/config/coapd.json'. The request body is empty.
- Response:** The response is a JSON object:

```
1 * {
2   "enable": true,
3   "port": 5683
4 }
```
- Status:** The response is successful, indicated by a green '200 OK' status, a response time of '3.12 s', and a size of '30 B'.
- Preview:** The response body is displayed in a preview window, showing the JSON structure.

12.5 Syslog

The LioN-X multi-protocol variants provide a Syslog client which can connect with a configured Syslog server and is able to log messages.

Syslog is a platform-independent standard for logging messages. Each message contains a timestamp as well as information about the severity level and the subsystem. The Syslog protocol RFC5424 is based on the Server-Client principle and lets machines and devices send messages in the network and collect them centrally. (For more details on the used syslog standard, please refer to <https://datatracker.ietf.org/doc/html/rfc5424>.)

LioN-X supports the storage of 256 messages in a ring buffer which are sent to the configured Syslog server. When the ring is full with 256 messages, the oldest message is always replaced by the newly arriving messages. All messages can be saved on the Syslog server. The Syslog client will not store any message permanently.

12.5.1 Syslog configuration

In **delivery state**, Syslog functions are **disabled**. The Syslog client can be configured either using the Web interface or directly via a JSON object sent in an HTTP/HTTPS request. For more information see chapter [Syslog configuration - Quick start guide](#) on page 110.

The configuration URL is:

```
http://[ip-address]/w/config/syslog.json
```

The configuration can also read back as a JSON file:

```
http://[ip-address]/r/config/syslog.json
```

The configuration is a JSON object. Each JSON member is a configuration element. The object must not contain all elements. Only the provided elements will be changed. The configuration changes apply only after a device restart.

The following configuration elements are available (default values in bold):

Element	Data type	Description	Example data
syslog-enable	boolean	Master switch for the Syslog client	true / false
global-severity	integer	<u>Severity level of Syslog client</u> 0 – Emergency 1 – Alert 2 – Critical 3 – Error 4 – Warning 5 – Notice 6 – Info 7 – Debug The client will log all messages of severity according to the setting, including all below levels.	0/1/2/ 3 /4/5/6/7
server-address	string (IP address)	IP address of the Syslog server	192.168.0.51 (Default: null)
server-port	integer (0 to 65535)	Server port of the Syslog server	514
server-severity	integer (0 to 7)	<u>Severity level of Syslog server</u> 0 – Emergency 1 – Alert 2 – Critical 3 – Error 4 – Warning 5 – Notice 6 – Info 7 – Debug	0/1/2/ 3 /4/5/6/7

Table 35: Syslog configuration

Syslog response:

The resulting response is a JSON object with a "status" field. Status should be "0" if no error occurred, and "-1" if there is an error.

In case of an error, the response contains an error array.

The error array contains an error object for each error occurred. The object consists of a field "Element" which names the config element that caused the error, and of a field "Message" for the error message.

Examples:

```
{ "status": -1, "error": [ { "Element": "upcua-enable", "Message": "Boolean
expected" } ] }

{ "status": 0 }

{ "status": -1, "error": [ { "Element": "root", "Message": "Not a JSON
object" } ] }
```

12.5.2 Syslog configuration - Quick start guide



Attention: Belden Deutschland GmbH is not responsible for any content of the referenced Web pages and provides no warranty for any functionality of the named third party software.

12.5.2.1 Syslog configuration via JSON

1. Depending on your application case, download and install *Insomnia* or a comparable application: <https://insomnia.rest/download/>

2. Configure Syslog:

POST: [IP-address]/w/config/syslog.json

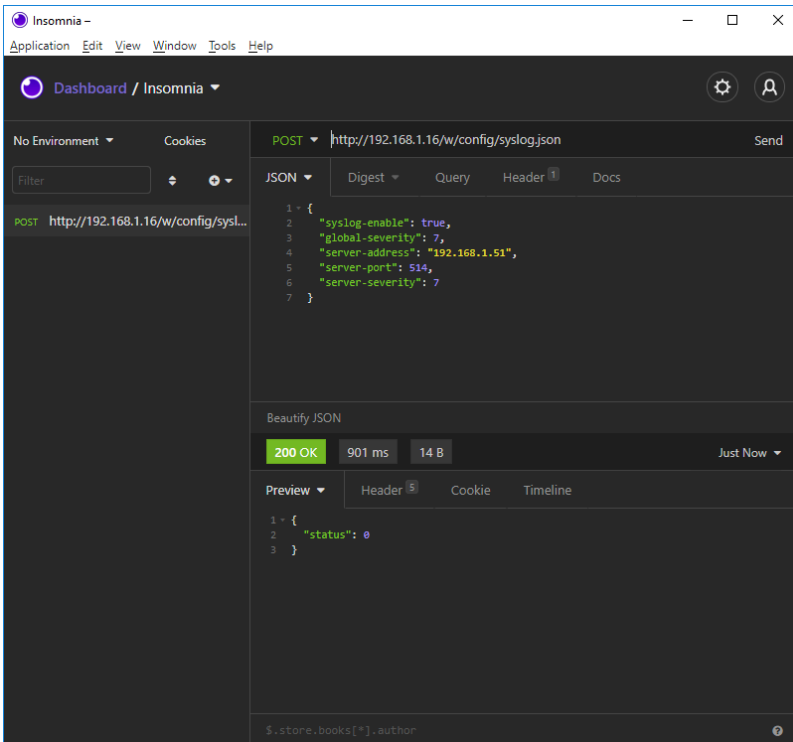

3. Read Syslog configuration:

GET: [IP-address]/r/config/syslog.json

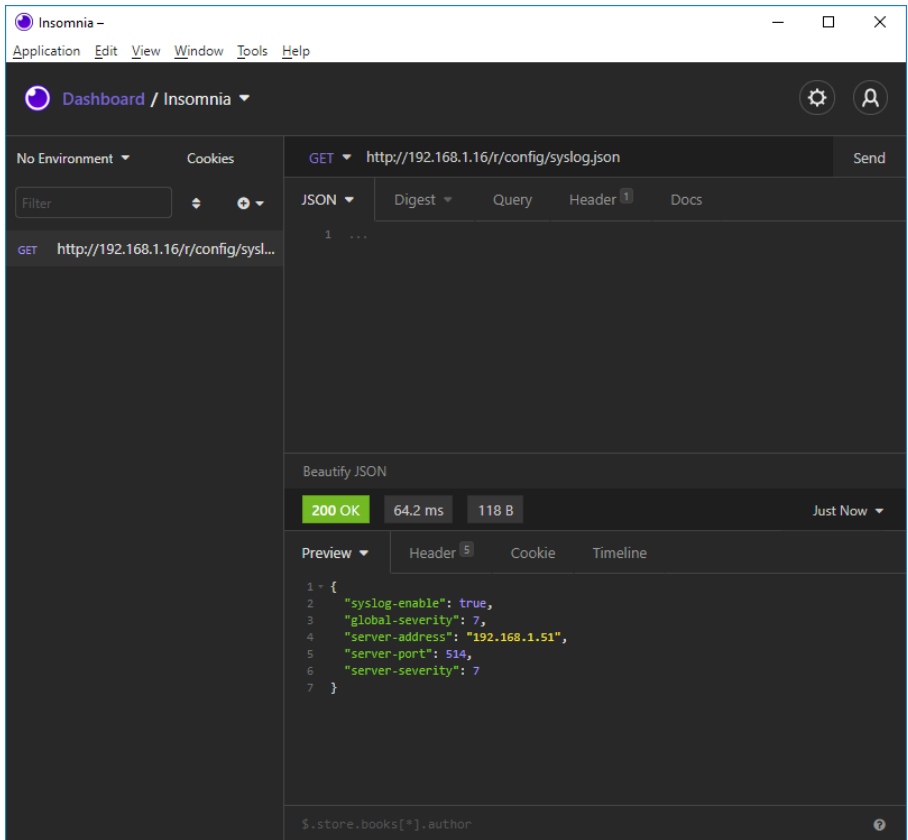

The screenshot shows the Insomnia REST client interface. The top bar displays "Insomnia -" and standard window controls. Below the menu bar, the "Dashboard / Insomnia" header is visible. The main interface is divided into several sections:

- Environment:** "No Environment" and "Cookies" are shown.
- Request:** A GET request to "http://192.168.1.16/r/config/syslog.json" is configured. The "Send" button is visible.
- Response:** The response is displayed in JSON format. The status is "200 OK", the response time is "64.2 ms", and the size is "118 B".
- Preview:** The response body is shown in a preview view, displaying the following JSON structure:

```
1 {
2   "syslog-enable": true,
3   "global-severity": 7,
4   "server-address": "192.168.1.51",
5   "server-port": 514,
6   "server-severity": 7
7 }
```

12.6 Network Time Protocol (NTP)

The LioN-X multi-protocol variants provide an NTP client (version 3) which can connect with a configured NTP server and is able to synchronize the network time at a configurable interval.

NTP is a network protocol which uses UDP datagrams to send and receive timestamps in order to synchronize with a local clock. The NTP protocol RFC1305 is based on the Server-Client principle and exclusively supplies the synchronization with Coordinated Universal Time (UTC). (For more details on the used NTP standard, please refer to <https://datatracker.ietf.org/doc/html/rfc1305>.)

12.6.1 NTP configuration

In **delivery state**, the NTP client is **disabled**. The NTP client can be configured either using the Web interface or directly via a JSON object sent in an HTTP/HTTPS request. For more information see chapter [NTP configuration - Quick start guide](#) on page 114.

The configuration URL is:

```
http://[ip-address]/w/config/ntpc.json
```

The configuration can also read back as a JSON file:

```
http://[ip-address]/r/config/ntpc.json
```

The configuration is a JSON object. Each JSON member is a configuration element. The object must not contain all elements. Only the provided elements will be changed. The configuration changes apply only after a device restart.

The following configuration elements are available (default values in bold):

Element	Data type	Description	Example data
NTP client state	boolean	Master switch for the NTP client	true / false
Server address	string	IP address of the NTP server	192.168.1.50
Server port	integer	Port of the NTP server	123
Update interval	integer	Interval at which the client will connect with the configured NTP server (see table row "Server address"). Note: This value is in seconds.	1/2/10/ 60

Table 36: NTP configuration

NTP response:

The resulting response is a JSON object with a "status" field. Status should be "0" if no error occurred, and "-1" if there is an error.

In case of an error, the response contains an error array.

The error array contains an error object for each error occurred. The object consists of a field "Element" which names the configuration element that caused the error, and of a field "Message" for the error message.

Examples:

```
{ "status": -1, "error": [{"Element": "ntpc-enable", "Message": "Boolean expected"}] }
{ "status": 0 }
{ "status": -1, "error": [{"Element": "root", "Message": "Not a JSON object"}] }
```

12.6.2 NTP configuration - Quick start guide



Attention: Belden Deutschland GmbH is not responsible for any content of the referenced Web pages and provides no warranty for any functionality of the named third party software.

12.6.2.1 NTP configuration via JSON

1. Depending on your application case, download and install *Insomnia* or a comparable application: <https://insomnia.rest/download/>

2. Configure NTP:

POST: [IP-address]/w/config/ntpc.json

The screenshot shows the Insomnia REST client interface. The top bar displays "Insomnia - Insomnia" and standard window controls. Below the menu bar, the "Dashboard / Insomnia" section is visible. The main workspace is divided into several panes:

- Left Pane:** Shows the request method "POST" and the URL "http://192.168.1.16/w/config/ntpc.json".
- Request Body:** A JSON object is displayed:

```
1 {
2   "enable": false,
3   "server-address": "192.168.1.8",
4   "server-port": 123,
5   "update-interval": 5
6 }
```
- Response:** Shows a "200 OK" status, a response time of "75.4 ms", and a response size of "14 B". The response body is:

```
1 {
2   "status": 0
3 }
```

3. Read NTP configuration:

GET: [IP-address]/r/config/ntpc.json

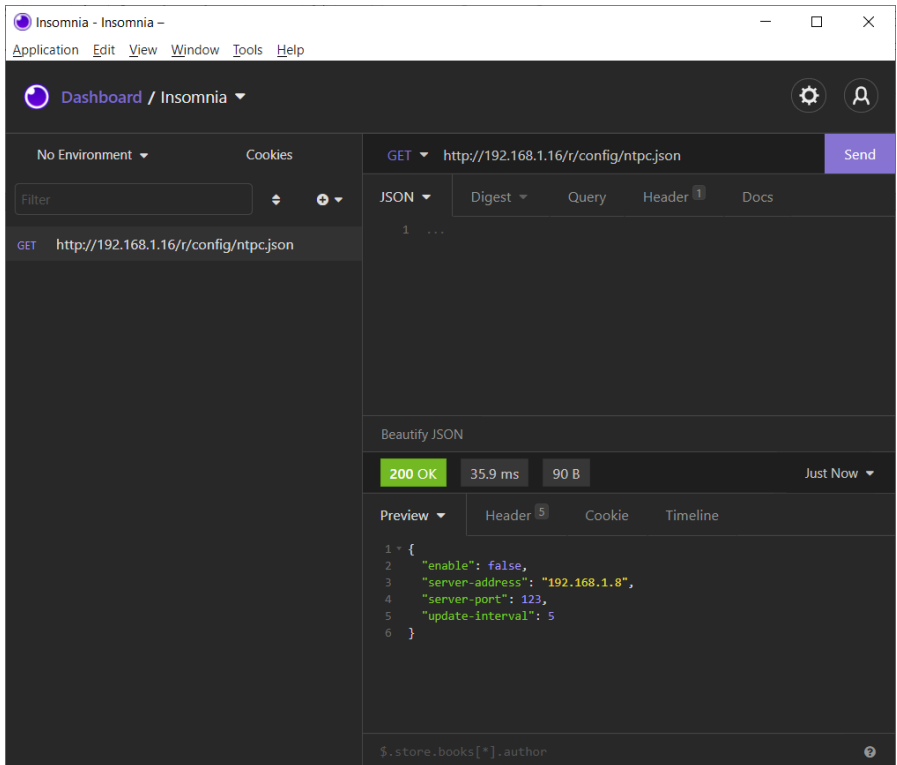

13 The integrated Web server

All device variants are equipped with an integrated Web server which makes functions for the device configuration and the display of status and diagnostic information available via a Web interface.

The Web interface provides an overview of the configuration and status of the device. It is also possible to use the Web interface to trigger a reboot, reset to the factory defaults, or perform a firmware update.

Enter "http://" followed by the IP address, such as "http://192.168.1.5", in your Web browser's address bar. If the status page of the device is not displayed, check your browser and firewall settings.

13.1 LioN-X 0980 XLC... variants

13.1.1 The Status page

The screenshot displays the 'LioN-X Digital Low Current Web Interface' with a navigation menu (Status, Parts, System, User, Contact) and a 'Status' section. The 'Device Overview' includes a graphical representation of the module with LEDs and rotary switches. The 'Device Information' table provides details about the device, and the 'Port Information' table lists the configuration and state of the I/O ports.

Device Information	
Name	LioN-X Digital 16DIO Low Current
Application Version	11.2.3.51903
Fieldbus Version	1.0.1.0
Bus	OPERATE
Device Diagnosis	
US Voltage	23.2V
UL Voltage	23.5V
Forcemode	Forcing is locked. <input type="button" value="Locked"/>

Port Information					
Channel	Type	Configuration	State	Dia	Details
X1 A	DIO	DIO	<input type="button" value="ON"/>		<input type="button" value="⊕"/>
X1 B	DIO	DIO	<input type="button" value="OFF"/>		<input type="button" value="⊕"/>
X2 A	DIO	DIO	<input type="button" value="OFF"/>		<input type="button" value="⊕"/>
X2 B	DIO	DIO	<input type="button" value="OFF"/>		<input type="button" value="⊕"/>
X3 A	DIO	DIO	<input type="button" value="OFF"/>		<input type="button" value="⊕"/>
X3 B	DIO	DIO	<input type="button" value="OFF"/>		<input type="button" value="⊕"/>
X4 A	DIO	DIO	<input type="button" value="OFF"/>		<input type="button" value="⊕"/>
X4 B	DIO	DIO	<input type="button" value="OFF"/>		<input type="button" value="⊕"/>
X5 A	DIO	DIO	<input type="button" value="OFF"/>		<input type="button" value="⊕"/>
X5 B	DIO	DIO	<input type="button" value="OFF"/>		<input type="button" value="⊕"/>
X6 A	DIO	DIO	<input type="button" value="OFF"/>		<input type="button" value="⊕"/>
X6 B	DIO	DIO	<input type="button" value="OFF"/>		<input type="button" value="⊕"/>
X7 A	DIO	DIO	<input type="button" value="OFF"/>		<input type="button" value="⊕"/>
X7 B	DIO	DIO	<input type="button" value="ON"/>		<input type="button" value="⊕"/>
X8 A	DIO	DIO	<input type="button" value="OFF"/>		<input type="button" value="⊕"/>
X8 B	DIO	DIO	<input type="button" value="OFF"/>		<input type="button" value="⊕"/>

The status page provides a quick overview of the current state of the device.

The left side shows a graphical representation of the module with all its LEDs and the positions of the rotary encoding switches.

The right side shows the "Device Information" table with some basic data for the module; for example, the variant, the cyclic communication status and a diagnostic indicator. The indicator shows whether diagnostics for the module exist.

The "Port Information" table shows the configuration and state of the I/O ports.

13.1.2 The Ports page

LioN-X Digital Low Current Web Interface

Status Ports System User Contact

Port Details

Show details for port

X1 X2 X3 X4 X5 X6 X7 X8

Port Information

Forcemode	Forcemode off
Port	X1
Dia	

Port Diagnosis

- No diagnosis

Pin 4 / Channel A

Type	DIO
Function	DIO
State	On
Output Restart	On
Input Logic	Normally Open
Input Filter	Off

Pin 2 / Channel B

Type	DIO
Function	DIO
State	Off
Output Restart	On
Input Logic	Normally Open
Input Filter	Off

The page shows detailed port information. In the field **Port Diagnosis**, incoming and outgoing diagnostics are displayed as clear text. **Pin 2** and **Pin 4** contain information about the configuration and state of the port.

13.1.3 The System page

LioN-X Digital Low Current Web Interface

Status
Ports
System
User
Contact

System

General Information

Firmware	
Application Version	11.2.3.51903
Fieldbus Version	1.0.1.0
Device	
Name	LioN-X Digital 16DIO Low Current
Product ID	0980 XLC 3900-121-007D-01F
Ordering Number	935715001
Hardware	1.0
Serial Number	123456
Production Date	2020-12-24T12:00:00Z
Ethernet	
MAC Address	3C B9 A6 20 05 30
Network	
Source	DCP
IP-Address	192.168.0.3
Subnetmask	255.255.255.0
Gateway	192.168.0.3
Fieldbus	
Name	PROFINET
State	OPERATE

IP Settings

IP configuration Manual DHCP

MQTT Config		OPC UA Server Config	
Mqtt state	Disabled	Opua state	Disabled
Broker	192.168.1.1	Port	4840
Port	1883	Anonymous login	Yes
Base Topic	lionx	Listen for Commands	No
Auto Publish	Yes	Process Forcing	No
Publish Interval (ms)	2000	Change Config	No
Publish Identity	Yes	Device Reset	No
Publish Config	Yes	Syslog	
Publish Status	Yes	Syslog state	Disabled
Publish Process	Yes	Global severity	3
Publish Devices	No	Server address	
Will State	Disabled	Server port	514
Will Topic		Server severity	3
Listen for Commands	No	CoAP	
Process Forcing	No	CoAP state	Disabled
Change Config	No	Port	5683
Device Reset	No	NTP	
QOS	At most once	NTP client state	Disabled
		Server address	0.0.0.0
		Server port	123
		Update interval	60

License Information

Config upload/download

Choose config file to upload:
 | Keine ausgewählt

Restart device

Confirm to restart the device. All connections will be closed.

Reset configuration to factory defaults

Restoring factory settings affects all network parameters, including fieldbus specific settings. All network connections will be closed.

Note: If the module has rotary switches, the new IP address is equivalent to the rotary switch position.

Confirm to reset the device. All configuration data will be overwritten by default values!

Firmware update

System diagnosis

Store timer:

System diagnosis severity Error Warning Information

The System page shows the basic information for the module like Firmware version, Device information, Ethernet, Network and Fieldbus information.

Config upload/download

With this feature, settings configured via the Web interface can be stored outside the I/O-Device (Download) for later Upload, e.g. after an I/O-Device change.

Config upload/download

Choose config file to upload:

No file selected.

Downloaded config_LioN-X_SN123456_2024-06-03T13-49-09.cfg

Restart Device

The module initializes a software reset.

Reset to Factory Settings

The module restores to the default factory settings.

IP Settings

Use this parameter to change the current IP address of the module.

For PROFINET, this is only useful during commissioning. Normally, the PLC sets the IP address at start-up by detecting the PROFINET module via its device name.

Firmware Update

The module initializes a Firmware update.



Attention: Firmware updates may only be performed in a non-production environment! The I/O data is not updated during the firmware update. As a minimum requirement, the controller must be in operating state “Stop”, or the connection to the controller must be disconnected before the update. The device automatically performs a reset during the update.

For a firmware update choose the *.ZIP container available on our website or ask our support team. Afterwards follow the instructions shown on your screen.

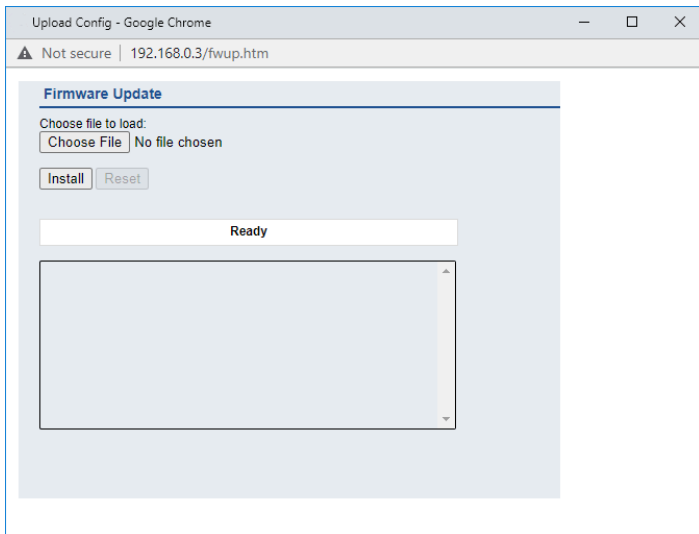

System diagnosis

All Syslog messages will be displayed in a ring buffer with 256 entries. With the 'Store timer', the nonvolatile storing interval can be set.

The default value is 'Off' (no nonvolatile storage of system diagnosis ring buffer).

The configuration is activated by clicking the button *Set configuration*.



13.1.4 The User page

Username	Groups	Edit	Del
admin	Admin, REST, WEB, OPC-UA, FWupdate, IOTconfig		

Add new user

Please change admin password

The User page provides the user management of the Web interface. New users with access rights "Admin" or "Write" can be added here. For security reasons please change the default admin password immediately after configuring the device.

Default user login data:

- ▶ User: admin
- ▶ Password: private

14 Technical data

The following sections give an overview of the most important functional data needed to operate the device. For further information and detailed technical data, see the respective **Data Sheet** of your required product in the product specific download area on <https://catalog.belden.com>.

14.1 General

Protection class (Only applies if the connectors are screwed together or if protective caps are used.) ¹	IP65 IP67 IP69K	
Ambient temperature (during operation and storage)	0980 XLC 3900... 0980 XLC 3901... 0980 XLC 3903... 0980 XLC 3923...	-40 °C .. +70 °C (-40 °F .. +158 °F)
Weight	LiON-X 60 mm	approx. 500 gr. (17.6 oz)
Ambient moisture	Max. 98% RH (For UL applications: Max. 80% RH)	
Housing material	Die-cast zinc	
Surface finish	Frosted nickel	
Flammability class	UL 94 (IEC 61010)	
Vibration resistance (oscillation) DIN EN 60068-2-6 (2008-11)	15 g/5–500 Hz	
Shock resistance DIN EN 60068-2-27 (2010-02)	50 g/11 ms +/- X, Y, Z	
Fastening torques	M4 fixing screws	1 Nm
	M4 ground connection	1 Nm
	M12 connector	0.5 Nm
Permitted cables	Ethernet cables according to IEEE 802.3, min. CAT 5 (shielded) Max. length of 100 m, not routed out of facility (= local network)	

Table 37: General information

¹ Not under UL investigation.

14.2 CC-Link IE Field Basic protocol

Protocol	CC-Link IE Field Basic
Update cycle	1 ms
Transmission rate	100 Mbit/s, full duplex
Transmission procedure Autonegotiation	100BASE-TX supported
Product type	12 (Communications Adapter)
Product ID	0980 XLC 3900-121-007D-01F, 935715001) 0980 XLC 3901-121-007D-01F, 935716001) 0980 XLC 3903-121-007D-01F, 935717001) 0980 XLC 3923-121-007D-01F, 935718001)
Supported Ethernet protocols	Ping ARP HTTP TCP/IP
Switch functionality	Integrated
CC-Link IE Field Basic interface	2 M12 sockets, 4-pin, D-coded (see Port assignments on page 30)
Connections	2 M12 Hybrid male/female, 8-pin
Autocrossing	supported
Electrically isolated Ethernet ports -> FE	2000 V DC

Table 38: CC-Link IE Field Basic protocol

14.3 Power supply of the module electronics/sensors

Port X03, X04	M12-L-coded Power, connector/socket, 5-pole Pin 1 / Pin 3		
Nominal voltage U_S	24 V DC (SELV/PELV)		
Current U_S	Max. 16 A		
Voltage range	21 .. 30 V DC		
Power consumption of module electronics	Typically 160 mA (+/-20 % at U_S nominal voltage)		
Power supply interruption	Max. 10 ms		
Voltage ripple U_S	Max. 5 %		
Current consumption sensor system (Pin 1)	0980 XLC 3900...	Port X1 .. X8 (Pin 1)	max. 2 A in total for X1 .. X8 (at $T_{\text{ambient}} = 30^\circ \text{C}$)
Current consumption sensor system (Pin 1)	0980 XLC 3901...	Port X1 .. X8 (Pin 1)	max. 2 A in total for X1 .. X8 (at $T_{\text{ambient}} = 30^\circ \text{C}$)
Current consumption sensor system (Pin 1)	0980 XLC 3903...	Port X1 .. X4 (Pin 1)	max. 2 A in total for X1 .. X4 (at $T_{\text{ambient}} = 30^\circ \text{C}$)
Current consumption sensor system (Pin 1)	0980 XLC 3923...	Port X1 .. X4 (Pin 1)	max. 0.2 A per port (at $T_{\text{ambient}} = 30^\circ \text{C}$)
Voltage level of the sensor power supply	Min. ($U_S - 1.5 \text{ V}$)		
Short circuit/overload protection of sensor supply	Yes, per port		
Reverse polarity protection	Yes		

Operational indicator (U _S)	LED green:	18 V (+/- 1 V) < U _S
	LED red:	U _S < 18 V (+/- 1 V)

*Table 39: Information on the power supply of the module electronics/
sensors*

14.4 Power supply of the actuators

Port X03, X04	M12_L-coded Power, connector/socket, 5-pole Pin 2 / Pin 4
Nominal voltage U_L	24 V DC (SELV/PELV)
Voltage range	18 .. 30 V DC
Current U_L	Max. 16 A
Voltage ripple U_L	Max. 5 %
Reverse polarity protection	Yes
Operational indicator (U_L)	LED green: $18 \text{ V (+/- 1 V)} < U_L$ LED red: $U_L < 18 \text{ V (+/- 1 V)}$ or $U_L > 30 \text{ V (+/- 1 V)}$ * if "Report U_L supply voltage fault" is enabled.

Table 40: Information on the power supply of the actuators

14.5 I/O ports

0980 XLC 3900...	Ports X1 .. X8	DI, DO	M12 socket, 5-pin
0980 XLC 3901...	Ports X1 .. X8	DI	M12 socket, 5-pin
0980 XLC 3903...	Ports X1 .. X4	DI	M12 socket, 5-pin
0980 XLC 3923...	Ports X5 .. X8	DO	

Table 41: I/O ports: Overview of functions

14.5.1 Digital inputs

Input connection	0980 XLC 3900...	Type 1 as per IEC 61131-2	
Input connection	0980 XLC 3901...	Type 1 as per IEC 61131-2	
Input connection	0980 XLC 3903...	Type 1 as per IEC 61131-2	
Input connection	0980 XLC 3923...	Type 3 as per IEC 61131-2	
Nominal input voltage	24 V DC		
Input current	Typically 3 mA		
Channel type	Normally open, p-switching		
Number of digital inputs	0980 XLC 3900... 0980 XLC 3901...	X1 .. X8	16
Number of digital inputs	0980 XLC 3903... 0980 XLC 3923...	X1 .. X4	8
Status indicator	yellow LED for Channel A (Pin 4) white LED for Channel B (Pin 2)		

Table 42: I/O ports configured as digital input

14.5.2 Digital outputs



Attention: Do not exceed the following maximum currents for the actuator supply:

- ▶ Max. 2.0 A per port
- ▶ Max. 5.0 A for each port pair X1/X2, X3/X4, X5/X6, X7/X8
- ▶ Max. 9.0 A in total for the whole port group X1 .. X8 (X5 .. X8 at 8DI8DO devices)

Pay attention to the derating!

Derating

Depending on the temperature, the module can be loaded with the following maximum total output current of the outputs:

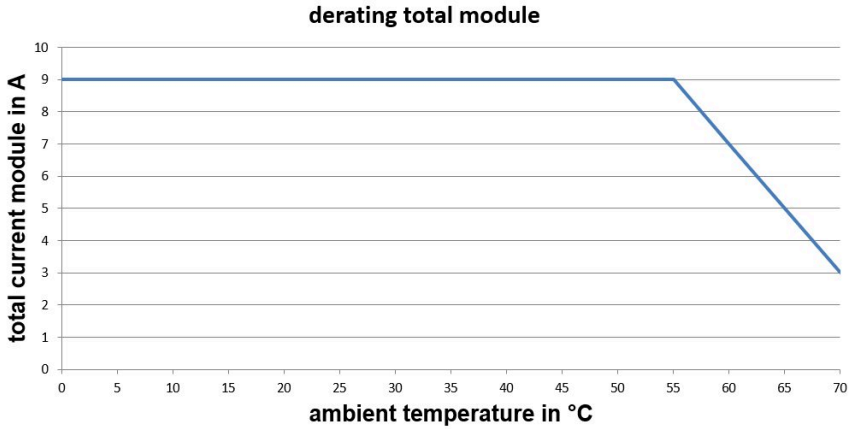

For applications with ambient temperatures higher than +55° C (131° F), a power supply cable (M12-L) with 2.5 mm² must be used.

Output type	normally open, p-switching	
Nominal output voltage per channel	Signal status "1" Signal status "0"	min. ($U_L - 1\text{ V}$) max. 2 V
Max. output current per device	0980 XLC 3900... 0980 XLC 3903... 0980 XLC 3923...	9 A
Max. output current per channel	0980 XLC 3900... (X1 .. X8) 0980 XLC 3903... (X5 .. X8) 0980 XLC 3923... (X5 .. X8)	2 A
Short-circuit/overload protected	yes/yes	
Behavior in case of short circuit or overload	deactivation with automatic power-on (parameterized)	
Number of digital outputs	0980 XLC 3900... (X1 .. X8)	16
Number of digital outputs	0980 XLC 3901...	0
Number of digital outputs	0980 XLC 3903... (X5 .. X8) 0980 XLC 3923... (X5 .. X8)	8
Status indicator	yellow LED per output Channel A (Pin 4) white LED per output Channel B (Pin 2)	

Table 43: I/O ports configured as digital output



Warning: If devices with electric isolation and devices without electric isolation are used within the same system, the electric isolation of all connected devices is annulled.

14.6 LEDs

LED	Color	Description
U _L	Green	Auxiliary sensor/actuator voltage OK $18\text{ V (+/- 1 V)} < U_L < 30\text{ V (+/- 1 V)}$
	Red [*]	Auxiliary sensor/actuator voltage LOW $U_L < 18\text{ V (+/- 1 V)}$ or $U_L > 30\text{ V (+/- 1 V)}$ [*] if "Report U _L supply voltage fault" is enabled.
	OFF	None of the above conditions.
U _S	Green	System/sensor voltage OK $18\text{ V (+/- 1 V)} < U_S < 30\text{ V (+/- 1 V)}$
	Red	System/sensor voltage LOW $U_S < 18\text{ V (+/- 1 V)}$ or $U_S > 30\text{ V (+/- 1 V)}$
	Red flashing	Device performs a factory reset (position of rotary encoding switches: 9-7-9)
OFF	None of the above conditions.	
X1 .. X8 A	Yellow	Status of digital input or digital output on pin 4 line "on".
	Yellow flashing	Short circuit on pin 4 line. / Overload or short circuit on L+ (pin 1) line / communication error
	OFF	None of the above conditions.
X1 .. X8 B	White	Status of digital input or digital output on pin 2 line "on".
	White flashing	Short circuit on pin 2 line. / Overload or short circuit on L+ (pin 1) line / communication error
	OFF	None of the above conditions.
P1 Lnk/Act P2 Lnk/Act	Green	Ethernet connection to another subscriber exists. Link detected.
	Yellow flashing	Data exchange with another subscriber.
	OFF	No connection to another subscriber. No link, no data exchange.

LED	Color	Description
RUN	Green	Device is in operation, cyclic transmission is in progress.
	Green flashing slowly at 2.5 Hz ("on" for 200 ms, "off" for 200 ms)	Device is in operation, cyclic transmission has stopped.
	Green flashing fast at 10 Hz ("on" for 50 ms, "off" for 50 ms)	Device not configured.
	OFF	No connection.
ERR	Red	Communication error.
	Red triple flash	DPM watchdog has expired.
	OFF	Device in normal operation.
IO	Red	Detected I/O error (output short circuit or Pin1 short circuit)
	OFF	No detected I/O error

Table 44: Information on the LED colors

14.7 Data transfer times

The following tables give an overview of the internal data transfer times of LioN-X.

There are three measured data direction values for each use case:

- ▶ **PLC to DO:** Transfer of a changed PLC output data to the digital output channel.
- ▶ **DI to PLC:** Transfer of a changed digital input signal on digital input channel to PLC.
- ▶ **Round-trip time (RTT):** Transfer of a changed PLC output data to digital output. The digital output is connected to a digital input. Transfer of the changed digital input signal on the channel to PLC. $RTT = [PLC\ to\ DO] + [DI\ to\ PLC]$.

The measured values are taken from the ethernet data transmission line. The values are therefore without PLC processing times and PLC cycle time.

For calculation of user specific data transfer and round-trip times of possible input filters, PLC processing and cycles times must be taken into calculation.

I/IOT disabled

Data direction	Data transfer time in ms		
	Minimum	Average	Maximum
PLC to DO	2.3	3.8	5.6
DI to PLC	5.9	6.8	7.8
RTT	8.5	10.7	12.0

I/IOT enabled

Data direction	Data transfer time in ms		
	Minimum	Average	Maximum
PLC to DO	2.5	3.8	5.5
DI to PLC	5.9	7.0	7.8
RTT	8.5	10.8	12.0

15 Recycling note



The symbol of a crossed-out wheeled bin shown on the device indicates that the device **MUST NOT** be disposed of with household waste at the end of its service life.

After its service life, the used device must be disposed of properly as electronic waste in accordance with the locally applicable disposal regulations.

End users are responsible for deleting personal data from the used device prior to disposal.

End users are obliged to separate used batteries and accumulators that are not enclosed by the used device from the used device in a nondestructive manner before disposing of the used device. The used batteries and accumulators must be handed in for separate collection. This does not apply if the used device is handed in for reuse.

16 Accessories

In order to get access to various types of accessories, please visit our Web page:

<https://www.belden.com>