



HIRSCHMANN

A **BELDEN** BRAND

User Manual

Installation

Industrial Ethernet Rail Switch SPIDER Standard Line PoE

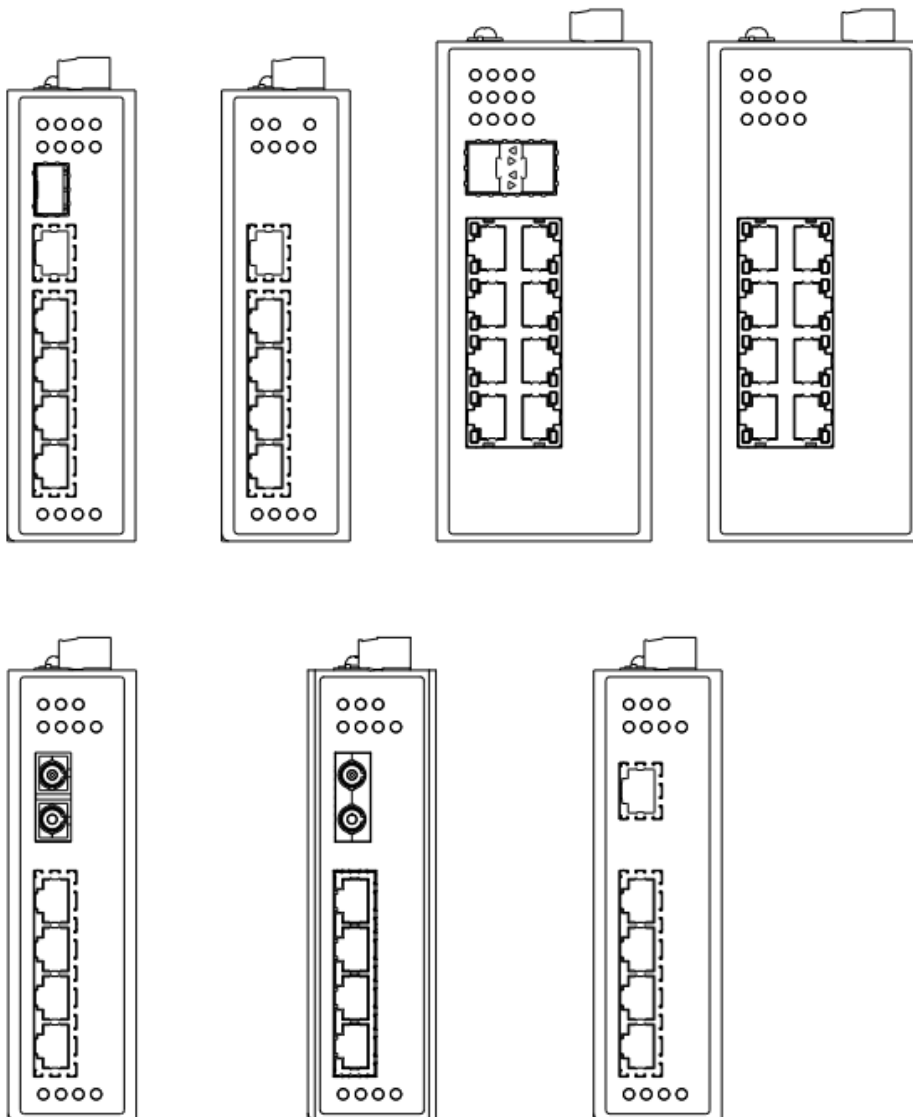

The naming of copyrighted trademarks in this manual, even when not specially indicated, should not be taken to mean that these names may be considered as free in the sense of the trademark and tradename protection law and hence that they may be freely used by anyone.

© 2025 Hirschmann Automation and Control GmbH

Manuals and software are protected by copyright. All rights reserved. The copying, reproduction, translation, conversion into any electronic medium or machine scannable form is not permitted, either in whole or in part. An exception is the preparation of a backup copy of the software for your own use.

The performance features described here are binding only if they have been expressly agreed when the contract was made. This document was produced by Hirschmann Automation and Control GmbH according to the best of the company's knowledge. Hirschmann reserves the right to change the contents of this document without prior notice. Hirschmann can give no guarantee in respect of the correctness or accuracy of the information in this document.

Hirschmann can accept no responsibility for damages, resulting from the use of the network components or the associated operating software. In addition, we refer to the conditions of use specified in the license contract.

You can get the latest version of this manual on the Internet at the Hirschmann product site (www.doc.hirschmann.com).

Hirschmann Automation and Control GmbH
Stuttgarter Str. 45-51
72654 Neckartenzlingen
Germany

Contents

Safety instructions	4
About this Manual	8
Legend	8
1 Description	9
1.1 General device description	9
1.2 Device name and product code	9
1.3 Device view	11
1.3.1 Front view.....	11
1.4 Power supply.....	13
1.5 Ethernet ports.....	13
1.5.1 10/100/1000 Mbit/s twisted pair port	13
1.5.2 10/100/1000 Mbit/s PoE port	13
1.5.3 10/100 Mbit/s twisted pair port.....	14
1.5.4 10/100 Mbit/s PoE port	14
1.5.5 100/1000 Mbit/s F/O port.....	14
1.5.6 100 Mbit/s F/O port.....	14
1.6 Pin assignments	15
1.7 Display elements	16
1.7.1 Power supply state	16
1.7.2 Port state	16
1.7.3 PoE state.....	17
2 Installation	19
2.1 Checking the package contents.....	19
2.2 Mounting the device	20
2.2.1 Installing the device onto the DIN rail.....	20
2.2.2 Grounding the device.....	20
2.3 Installing an SFP transceiver (optional)	21
2.4 Adjust DIP switch settings	22
2.5 Wiring the terminal block for the supply voltage and the grounding	23
2.6 Operating the device	24
2.7 Connecting data cables	24
3 Monitoring the ambient air temperature	25
4 Maintenance and service	26
5 Disassembly	27
5.1 Removing an SFP transceiver (optional)	27
5.2 Removing the device	27
6 Technical data	28
A. Further Support	34

Safety instructions

■ General safety instructions

You operate this device with electricity. Improper usage of the device entails the risk of physical injury or significant property damage. The proper and safe operation of this device depends on proper handling during transportation, proper storage and installation, and careful operation and maintenance procedures.

- Before connecting any cable, read this document, and the safety instructions and warnings.
- Operate the device with undamaged components exclusively.
- The device is free of any service components. In case of a damaged or malfunctioning the device, turn off the supply voltage and return the device to Hirschmann for inspection.

■ Certified usage

- Use the product only for the application cases described in the Hirschmann product information, including this manual.
- Operate the product only according to the technical specifications. See “Technical data” on page [28](#).
- Connect to the product only components suitable for the requirements of the specific application case.

■ Installation site requirements

- Install the device in a fire enclosure according to EN 60950-1.

■ Device casing

Only technicians authorized by the manufacturer are permitted to open the casing.

- Never insert pointed objects (narrow screwdrivers, wires, etc.) into the device or into the connection terminals for electric conductors. Do not touch the connection terminals.
- Install the device in the vertical position.

■ Qualification requirements for personnel

- Only allow qualified personnel to work on the device.

Qualified personnel have the following characteristics:

- ▶ Qualified personnel are properly trained. Training as well as practical knowledge and experience make up their qualifications. This is the prerequisite for grounding and labeling circuits, devices, and systems in accordance with current standards in safety technology.
- ▶ Qualified personnel are aware of the dangers that exist in their

work.

- ▶ Qualified personnel are familiar with appropriate measures against these hazards in order to reduce the risk for themselves and others.
- ▶ Qualified personnel receive training on a regular basis.

- National and international safety regulations
Verify that the electrical installation meets local or nationally applicable safety regulations.
- Grounding the device
The device is grounded by means of a separate ground screw.
- Requirements for connecting electrical wires
Before connecting the electrical wires, **always** verify that the requirements listed are complied with.

General requirements for connecting electrical wires

The following requirements apply without restrictions:

- ▶ The electrical wires are voltage-free.
- ▶ The cables used are permitted for the temperature range of the application case.
- ▶ This device must be operated with a separate power supply or DC/DC converter with galvanically separated SELV/PELV output voltages.
- ▶ ⚠: Relevant for North America: Use 75 °C copper (Cu) wire only (Utilisez uniquement des câbles en cuivre (Cu) 75 ° C)

Requirements for connecting the supply voltage

The following requirements apply without restrictions:

The power supply cable is suitable for the voltage, the current and the physical load. Hirschmann recommends a wire diameter of 0.81-3.33mm² (18~12AWG). The cross-section of the ground conductor is the same size as or bigger than the cross-section of the power supply cables. The max torque of the terminal block screws is M3,6.0 Lb.in.

The following requirements apply alternatively:

Alternative 1	The power supply complies with the requirements for a limited power source as per EN 60950-1.
Alternative 2	All of the following requirements are complied with: <ul style="list-style-type: none">▶ The power supply complies with the requirements for a safety extra-low voltage (SELV) as per IEC/EN 60950-1.▶ A fuse suitable for DC voltage is located in the plus conductor of the power supply. The minus conductor is on ground potential. Otherwise, a fuse is also located in the minus conductor. Regarding the properties of this fuse: See "General technical data" on page 28.

- Supply voltage
The supply voltage is only connected with the ground connection via protective elements.

■ E marking

This applies to the following device variants only:

- ▶ SPIDER-SL-24-05T1999999Txxxxxx

The labeled devices comply with the regulations contained in the following European directive(s):

UN/ECE Regulation No. 10

Uniform provisions concerning the approval of vehicles with regard to electromagnetic compatibility.

UN/ECE Regulation No. 118

Uniform technical prescriptions concerning the burning behaviour and/or the capability to repel fuel or lubricant of materials used in the construction of certain categories of motor vehicles.

Note: For use in connection with a suitable type approved power supply only.

Certified devices are marked with an E type approval indicator.

■ CE marking

The labeled devices comply with the regulations contained in the following European directive(s):

2011/65/EU (RoHS)

Directive of the European Parliament and of the Council on the restriction of the use of certain hazardous substances in electrical and electronic equipment.

2014/30/EU (EMC)

Directive of the European Parliament and the council for standardizing the regulations of member states with regard to electromagnetic compatibility.

In accordance with the above-named EU directive(s), the EU conformity declaration will be available to the relevant authorities at the following address:

Hirschmann Automation and Control GmbH
Stuttgarter Str. 45-51
72654 Neckartenzlingen
Germany

The device can be used in the industrial sector.

- ▶ Interference immunity: EN 61000-6-2
- ▶ Emitted interference: EN 55032

You find more information on technical standards here:
“Technical data” on page [28](#).

The assembly guidelines provided in these instructions must be strictly adhered to in order to observe the EMC threshold values.

Warning! This is a class A device. This device can cause interference in living areas, and in this case the operator may be required to take appropriate measures.

■ **FCC note:**

This device complies with part 15 of the FCC rules. Operation is subject to the following two conditions: (1) this device may not cause harmful interference; (2) this device must accept any interference received, including interference that may cause undesired operation. Appropriate testing has established that this device fulfills the requirements of a class A digital device in line with part 15 of the FCC regulations.

These requirements are designed to provide sufficient protection against interference when the device is being used in a business environment. The device creates and uses high frequencies and can also radiate these frequencies. If it is not installed and used in accordance with this operating manual, it can cause radio transmission interference. The use of this device in a residential area can also cause interference, and in this case the user is obliged to cover the costs of removing the interference.

■ **UL Approval:**

This device complies with UL 61010-1 and UL 61010-2-201. If the equipment is used in a manner not specified by the manufacturer, the protection provided by the equipment may be impaired.

■ **Recycling note**



After usage, this device must be disposed of properly as electronic waste, in accordance with the current disposal regulations of your county, state, and country.

About this Manual

The “Installation User Manual” document contains a device description, safety instructions, a display description and further information that you require to install the device.

Legend

The symbols used in this manual have the following meanings:

	Listing
	Work step
	Subheading

1 Description

1.1 General device description

The SPIDER-SL PoE devices are designed for the special requirements of industrial automation. They meet the relevant industry standards, provide very high operational reliability, even under extreme conditions, and also long-term reliability and flexibility.

The SPIDER-SL PoE is a power sourcing equipment (PSE), provides up to 8 Power-over-Ethernet ports. Through a twisted-pair cable connected to the 10/100/1000 Mbit/s PoE port, the device provides power for a powered device (PD) such as a WLAN access point, an IP camera or an IP telephone. With the presence of the PoE power supply, a separate power supply for the powered device is unnecessary.

You have numerous options of combining the device characteristics. You can determine the possible combinations using the configurator which is available in the Belden E-Catalog (www.e-catalog.beldensolutions.com) on the web page of the device.

1.2 Device name and product code

The device name corresponds to the product code. The product code is made up of characteristics with defined positions. The characteristic values stand for specific product properties.

Item	Characteristic	Characteristic value	Description
1 ... 9	Product	SPIDER-SL	SPIDER Standard Line
10	(hyphen)	-	
11	Data rate	2	10/100 Mbit/s
		4	10/100/1000 Mbit/s
12	Power over Ethernet (PoE)	4	PoE+ support
			(hyphen)
14 ... 17	Number Twisted pair ports	04T1	4 × Twisted Pair TX, RJ45
		05T1	5 × Twisted Pair TX, RJ45
		08T1	8 × Twisted Pair TX, RJ45
18 ... 19	Optical fiber port 1	M2	DSC multimode socket for 100 Mbit/s F/O connections
		S2	DSC singlemode socket for 100 Mbit/s F/O connections
		M4	ST multimode socket for 100 Mbit/s F/O connections
		S4	ST singlemode socket for 100 Mbit/s F/O connections

Item	Characteristic	Characteristic value	Description
		O6	SFP slot for 100/1000 Mbit/s F/O connections
		99	without
20 ... 21	Optical fiber port 2	O6	SFP slot for 100/1000 Mbit/s F/O connections
		99	without
22 ... 23	Optical fiber port 3	99	without
24	Temperature range	T	Extended -40 °C ... +70 °C (-40 °F ... +158 °F)
25 ... 26	Certificates and declarations	Y9	CE, FCC, EN61131,UL61010
		RY	Y9 + E1
27 ... 28	Customer-specific version	HH	Hirschmann standard
29 ... 30	Configuration	HH	Hirschmann standard

Table 1: Device name and product code

1.3 Device view

1.3.1 Front view

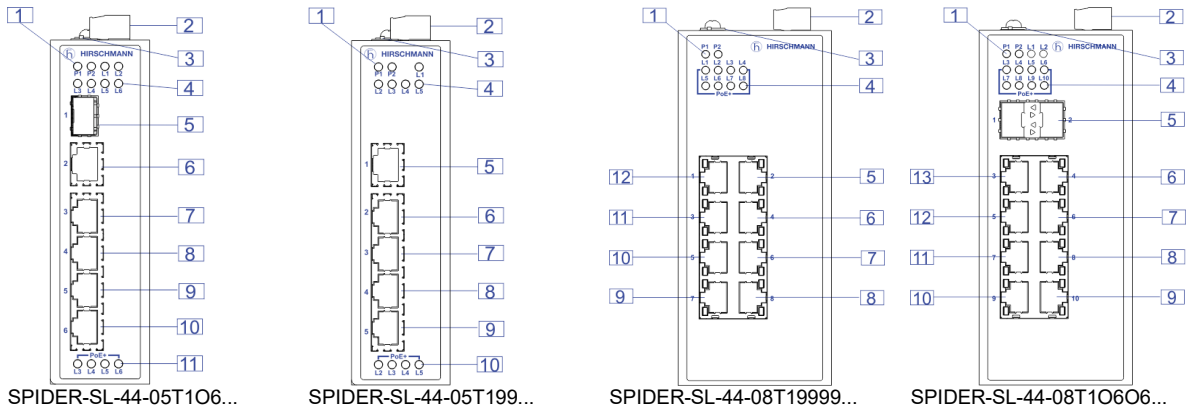

Front view using example of device variants SPIDER-SL-44...

SPIDER-SL-44-05T106...

1	LED display elements for power supply status
2	4-pin, pluggable terminal block for power supply
3	DIP
4	LED display elements for port status
5	1 × SFP slot for 100/1000 Mbit/s F/O connections
6	1 × RJ45 socket for 10/100/1000 Mbit/s Twisted Pair connections
7 ... 10	4 × RJ45 socket for 10/100/1000 Mbit/s PoE+ port
11	LED display elements for PoE status

SPIDER-SL-44-05T199...

1	LED display elements for power supply status
2	4-pin, pluggable terminal block for power supply
3	DIP
4	LED display elements for port status
5	1 × RJ45 socket for 10/100/1000 Mbit/s Twisted Pair connections
6 ... 9	4 × RJ45 socket for 10/100/1000 Mbit/s PoE+ port
10	LED display elements for PoE status

SPIDER-SL-44-08T1999...

1	LED display elements for power supply status
2	4-pin, pluggable terminal block for power supply
3	DIP
4	LED display elements for PoE status
5 ... 12	8 × RJ45 socket for 10/100/1000 Mbit/s PoE+ port

SPIDER-SL-44-08T10606...

1	LED display elements for power supply status
2	4-pin, pluggable terminal block for power supply
3	DIP
4	LED display elements for PoE status
5	2 × SFP slot for 100/1000 Mbit/s F/O connections
6 ... 13	8 × RJ45 socket for 10/100/1000 Mbit/s PoE+ port

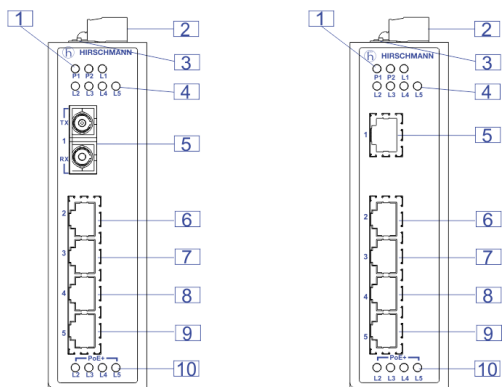

SPIDER-SL-24-04T1...

SPIDER-SL-24-05T1...

Front view using example of device variants SPIDER-SL-24...

SPIDER-SL-24-04T1...

1	LED display elements for power supply status
2	4-pin, pluggable terminal block for power supply
3	DIP
4	LED display elements for port status
5	depending on device variant <ul style="list-style-type: none"> ▶ DSC multimode socket for 100 Mbit/s F/O connections ▶ DSC singlemode socket for 100 Mbit/s F/O connections ▶ ST multimode socket for 100 Mbit/s F/O connections ▶ ST singlemode socket for 100 Mbit/s F/O connections
6 ... 9	4 × RJ45 socket for 10/100 Mbit/s PoE+ port
10	LED display elements for PoE status

SPIDER-SL-24-05T1...

1	LED display elements for power supply status
2	4-pin, pluggable terminal block for power supply
3	DIP
4	LED display elements for port status
5	1 × RJ45 socket for 10/100 Mbit/s twisted pair connections
6 ... 9	4 × RJ45 socket for 10/100 Mbit/s PoE+ port
10	LED display elements for PoE status

1.4 Power supply

You have the following options to supply your device with voltage:

- Power supply via a 4-pin terminal block
For the power supply of the device, a 4-pin terminal block is available.
For further information see [“Wiring the terminal block for the supply voltage and the grounding”](#) on page [23](#).

1.5 Ethernet ports

You can connect end devices and other segments to the device ports using twisted pair cables or optical fibers (F/O).

The PoE port of the device (Endpoint PSE) supplies voltage to the twisted pair cables via the wire pairs carrying the signal (Alternative A) You find information on pin assignments for making patch cables here: “Pin assignments” on page [15](#).

1.5.1 10/100/1000 Mbit/s twisted pair port

This port is an RJ45 socket.

The 10/100/1000 Mbit/s twisted pair port offers you the ability to connect network components

This port supports:

- ▶ Autonegotiation
- ▶ Autopolarity
- ▶ Autocrossing
- ▶ 1000 Mbit/s full duplex
- ▶ 100 Mbit/s half-duplex mode, 100 Mbit/s full duplex mode
- ▶ 10 Mbit/s half-duplex mode, 10 Mbit/s full duplex mode

1.5.2 10/100/1000 Mbit/s PoE port

This port is an RJ45 socket.

The 10/100/1000 Mbit/s PoE port allows you to connect network components such as a powered device (PD)

This port supports:

- ▶ Autonegotiation
- ▶ Autopolarity
- ▶ Autocrossing
- ▶ 1000 Mbit/s full duplex

- ▶ 100 Mbit/s half-duplex mode, 100 Mbit/s full duplex mode
- ▶ 10 Mbit/s half-duplex mode, 10 Mbit/s full duplex mode
- ▶ Power over Ethernet (PoE/PoE+)

1.5.3 10/100 Mbit/s twisted pair port

This port is an RJ45 socket.

The 10/100 Mbit/s twisted pair port offers you the ability to connect network components

This port supports:

- ▶ Autonegotiation
- ▶ Autopolarity
- ▶ Autocrossing
- ▶ 100 Mbit/s half-duplex mode, 100 Mbit/s full duplex mode
- ▶ 10 Mbit/s half-duplex mode, 10 Mbit/s full duplex mode

1.5.4 10/100 Mbit/s PoE port

This port is an RJ45 socket.

The 10/100 Mbit/s PoE port allows you to connect network components such as a powered device (PD)

This port supports:

- ▶ Autonegotiation
- ▶ Autopolarity
- ▶ Autocrossing
- ▶ 100 Mbit/s half-duplex mode, 100 Mbit/s full duplex mode
- ▶ 10 Mbit/s half-duplex mode, 10 Mbit/s full duplex mode
- ▶ Power over Ethernet (PoE/PoE+)

1.5.5 100/1000 Mbit/s F/O port

This port is an SFP slot. The 100/1000 Mbit/s F/O port offers you the ability to connect network components.

This port supports:

- ▶ 100 Mbit/s full duplex when using a Fast Ethernet SFP transceiver
- ▶ 1000 Mbit/s full duplex when using a Gigabit Ethernet SFP transceiver

1.5.6 100 Mbit/s F/O port

The 100 Mbit/s F/O port offers you the ability to connect network components.

This port supports:

- ▶ Full duplex mode

1.6 Pin assignments

Pin assignment of a TP/TX interface in MDI mode, RJ45 socket

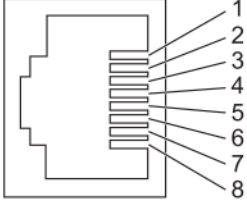
RJ45	Pin	10/100 Mbit/s	1000 Mbit/s	PoE voltage
	MDI mode			
	1	TX+	BI_DA+	Plus terminal
	2	TX-	BI_DA-	Plus terminal
	3	RX+	BI_DB+	Minus terminal
	4	-	BI_DC+	
	5	-	BI_DC-	
	6	RX-	BI_DB-	Minus terminal
	7	-	BI_DD+	
8	-	BI_DD-		

1.7 Display elements

After the supply voltage is switched on, the device performs a self-test. During this process, various LEDs light up.

1.7.1 Power supply state

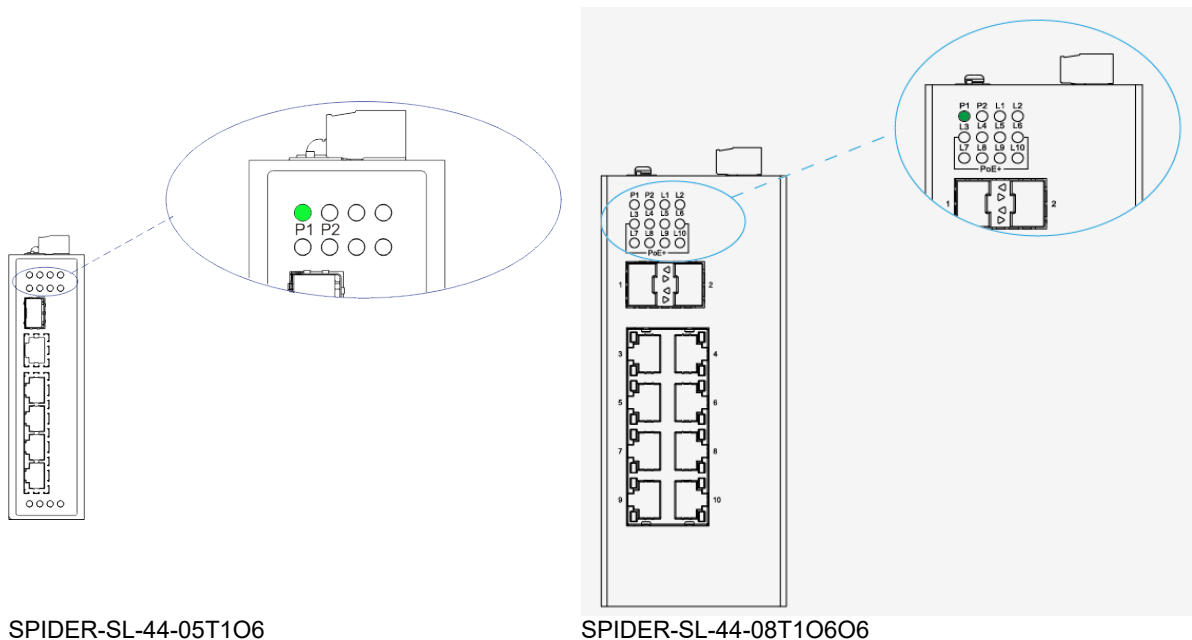

SPIDER-SL-44-05T106

SPIDER-SL-44-08T10606

This LED provides information on the status of the power supply.

LED	Color	Activity	Meaning
P1	Green	Lights up	The operating voltage 1 is on
		None	The operating voltage 1 is off
P2	Green	Lights up	The operating voltage 2 is on
		None	The operating voltage 2 is off

1.7.2 Port state

These LEDs provide port-related information.

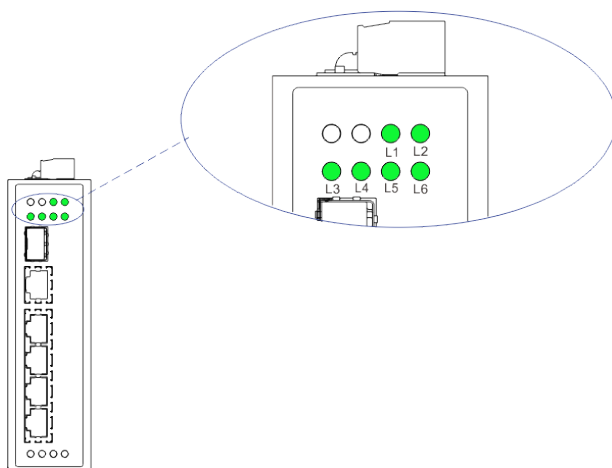

SPIDER-SL-44-05T106

L/D (link status/data)	Color	Activity	Meaning
	Green	Lights up	Device detects a valid link
		Flashing	Device is transmitting and/or receiving data
		None	Device detects an invalid or missing link

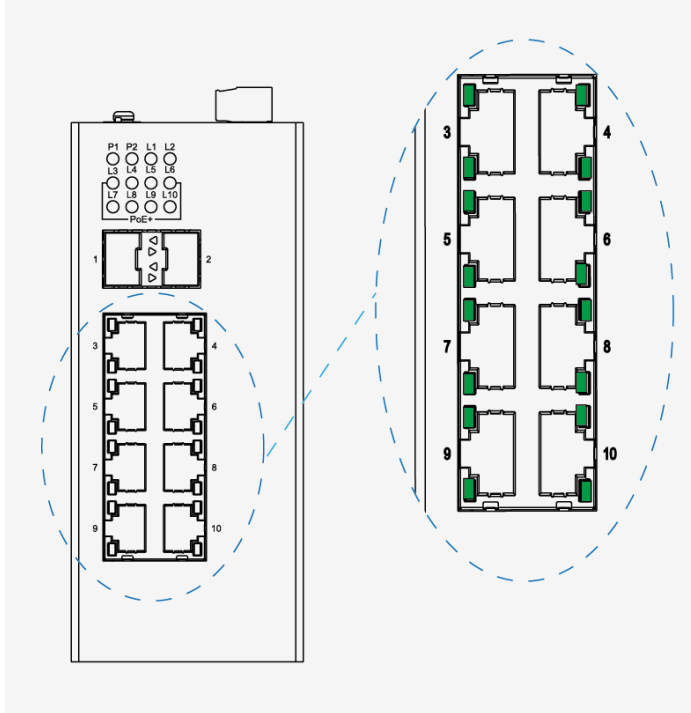

SPIDER-SL-44-08T10606

L/D (link status/data)	Color	Activity	Meaning
	Green	Lights up	Device detects a valid link
		Flashing	Device is transmitting and/or receiving data
		None	Device detects an invalid or missing link

SP (data rate)	Color	Activity	Meaning
	Green	Lights up	1000 Mbit/s connection
		None	10/100 Mbit/s connection

1.7.3 PoE state

These LEDs provide information on the status of the PoE.

LED	Color	Activity	Meaning
	Green	Lights up	The PoE power supply is active
		None	The PoE power supply is inactive

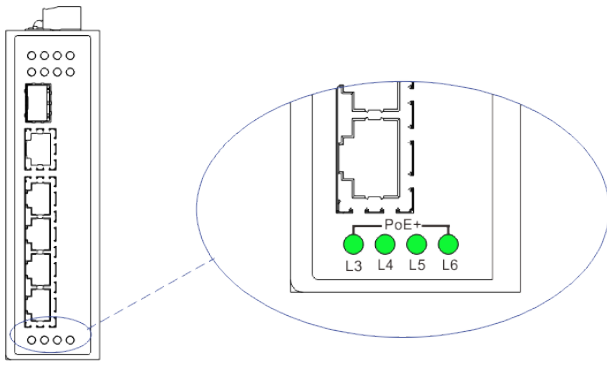

SPIDER-SL-44-05T106

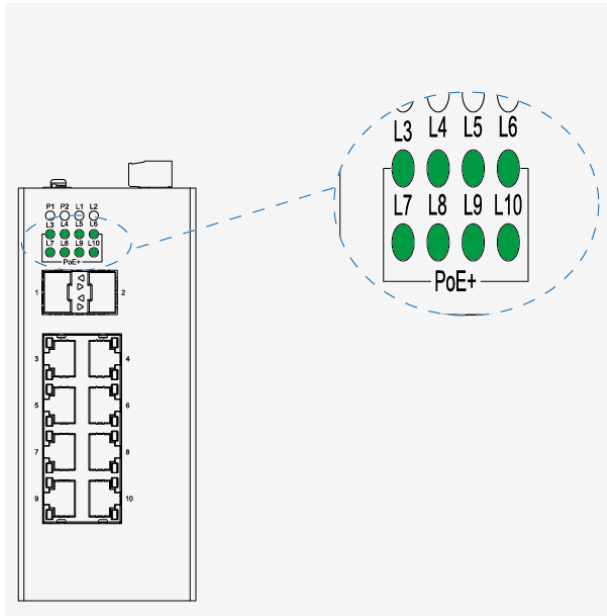

SPIDER-SL-44-08T106O6

2 Installation

The devices have been developed for practical application in a harsh industrial environment but for indoor use only.

The typical final cabinet operating environment of the device meets the requirements of IP30 or better.

On delivery, the device is ready for operation.

To configure a subdomain, follow these steps:

- ▶ Checking the package contents
- ▶ Mounting the device
- ▶ Installing an SFP transceiver (optional)
- ▶ Wiring the terminal block for the supply voltage and the grounding
- ▶ Operating the device
- ▶ Connecting data cables

2.1 Checking the package contents

- Check whether the package includes all items named in the section “Scope of delivery” on page [31](#).
- Check the individual parts for transport damage.

2.2 Mounting the device

Installing the device onto the DIN rail

2.2.1 Installing the device onto the DIN rail

Prerequisite:

The device is for mounting on a 35 mm DIN rail in accordance with DIN EN 60715.

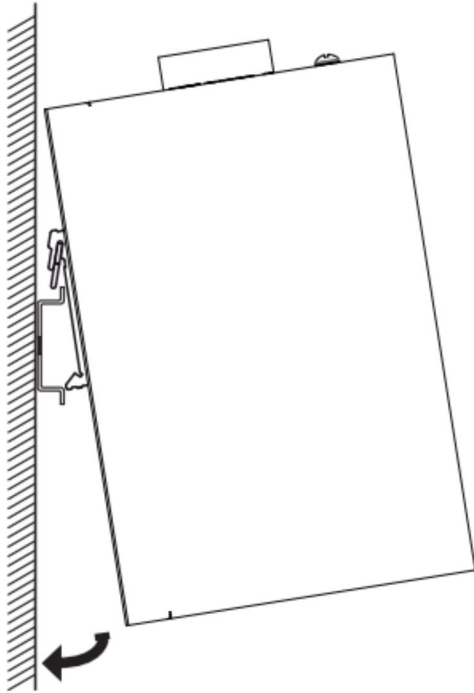

Proceed as follows:

- Slide the upper stiff metal spring of the device into the DIN rail.
- Press the device downwards onto the clip-in bar.
- Snap in the device.

2.2.2 Grounding the device

The device has a functional ground connection.

The device is grounded via the separate ground screw.

Note: Ground the device before connecting any other cables.

2.3 Installing an SFP transceiver (optional)

Prerequisite:

- ▶ Use only Hirschmann SFP transceivers which are suitable for usage with the device.

See “Accessories” on page [31](#).



Proceed as follows:

- Remove the protection cap from the SFP transceiver.
- Push the transceiver with the lock closed into the slot until it latches in.

2.4 Adjust DIP switch settings

The 2-pin DIP switch on the top of the device gives you the following options:

Device	DIP Switch	Setting	Description
SPIDER-SL-44-05T106...	100/1GSFP	ON	Supports 1000M SFP module
		OFF	Supports 100M SFP module
	Jumbo	ON	Enable Jumbo frame function
		OFF	Disable Jumbo frame function
SPIDER-SL-44-05T199...	N.C.	--	Serves no function
	Jumbo	ON	Enable Jumbo frame function
		OFF	Disable Jumbo frame function
SPIDER-SL-44-08T19999...	N.C.	--	Serves no function
	Jumbo	ON	Enable Jumbo frame function
		OFF	Disable Jumbo frame function
SPIDER-SL-44-08T10606...	N.C.	--	Serves no function
	Jumbo	ON	Enable Jumbo frame function
		OFF	Disable Jumbo frame function
SPIDER-SL-24-...	N.C.	--	Serves no function
	Jumbo	ON	Enable Jumbo frame function
		OFF	Disable Jumbo frame function

Note: For the SPIDER-SL-44-05..., you must restart the device for the changes to take effect after modifying the DIP switch.

- Before starting operation of the device, check whether the default settings of the DIP switch correspond to your requirements.

2.5 Wiring the terminal block for the supply voltage and the grounding

⚠ WARNING

ELECTRIC SHOCK

Connect only a supply voltage that corresponds to the type plate of your device.

Never insert sharp objects (small screwdrivers, wires, etc.) into the connection terminals for the supply voltage, and do not touch the terminals.

Failure to follow these instructions can result in death, serious injury, or equipment damage.

A 4-pin terminal block is used for connecting the supply voltage and it is a redundant power.
A grounded screw is used for the grounding.

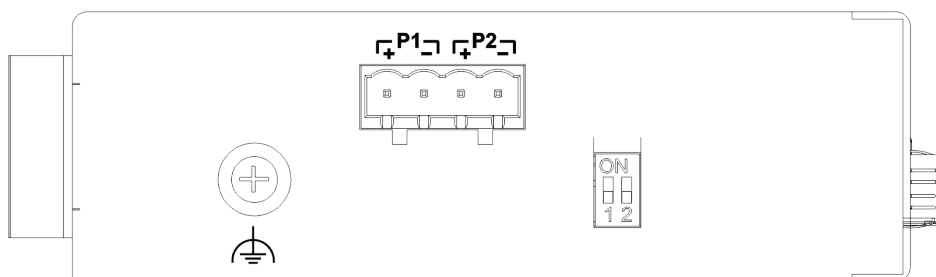

Figure 1: 4-pin, pluggable terminal block for power supply

Type of the voltages that can be connected	Specification of the supply voltage		Connections
DC voltage	Rated voltage range DC 12 V ... 57V	+	Plus terminal of the supply voltage
		-	Minus terminal of the supply voltage

Table 2: Type and specification of the supply voltage and pin assignment on the device

- The operating voltage can be connected redundantly. Both inputs are uncoupled. There is no distributed load. With redundant supply, the power supply unit with the higher output voltage supplies the device on its own.

Proceed as follows:

- Ensure the required conditions for connecting the supply voltage.
- See “Requirements for connecting electrical wires” on page [4](#).
- Pull the terminal block off the device.
- Connect the ground connection.
- Connect the power supply cables.
- Plug the terminal block into the connection on the housing.

2.6 Operating the device

By connecting the supply voltage via the terminal block, you start the operation of the device.

2.7 Connecting data cables

Note the following general recommendations for data cable connections in environments with high electrical interference levels:

- ▶ Keep the length of the data cables as short as possible.
 - ▶ Use optical data cables for the data transmission between the buildings.
 - ▶ When using copper cables, provide a sufficient separation between the power supply cables and the data cables. Ideally, install the cables in separate cable channels.
 - ▶ Verify that power supply cables and data cables do not run parallel over longer distances, and that ideally they are installed in separate cable channels. If reducing the inductive coupling is necessary, verify that the power supply cables and data cables cross at a 90° angle.
 - ▶ Use shielded cables (SF/UTP cables as per ISO/IEC 11801:2002).
 - ▶ Beware of possible short circuits when connecting a cable section with conductive shielding braiding.
-
- Connect the data cables according to your requirements.

3 Monitoring the ambient air temperature

Operate the device below the specified maximum ambient air temperature exclusively.

See “General technical data” on page [27](#).

The ambient air temperature is the temperature of the air at a distance of 2 in (5 cm) from the device. It depends on the installation conditions of the device, e.g. the distance from other devices or other objects, and the output of neighboring devices.

NOTE: We recommend the installation environment for the equipment is: 0.8 in (2 cm) left and right spacing, 2 in (5 cm) up and down

4 Maintenance and service

When designing this device, Hirschmann largely avoided using high-wear parts. The parts subject to wear and tear are dimensioned to last longer than the lifetime of the product when it is operated normally. Operate this device according to the specifications. Depending on the degree of pollution in the operating environment, check at regular intervals that the ventilation slots in the device are not obstructed.

 CAUTION
RISK OF TRANSIENTS OR ELECTROSTATIC DISCHARGES Do not open the housing. Failure to follow these instructions can result in injury or equipment damage.

Note: You will find information about the complaints and returns procedures on the Internet under <http://www.beldensolutions.com/en/Service/Repairs/index.phtml> .

5 Disassembly

5.1 Removing an SFP transceiver (optional)

Proceed as follows:

- Pull the SFP transceiver out of the slot by means of the opened lock.
- Close the SFP transceiver with the protective cap.

5.2 Removing the device

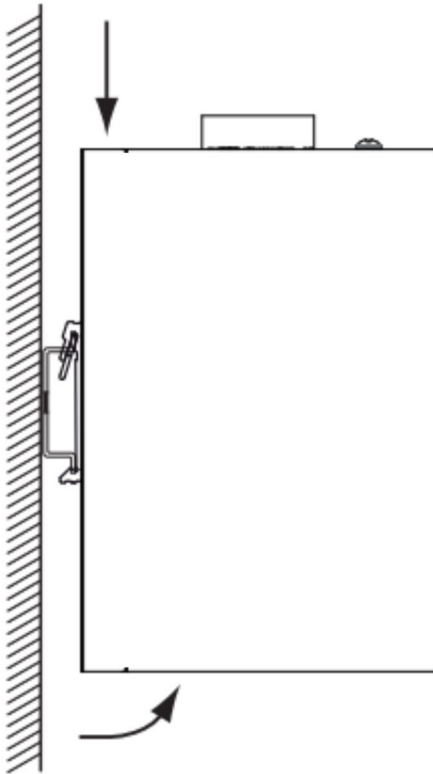

Proceed as follows:

- ▶ Disconnect the data cables.
- ▶ Disable the supply voltage.
- ▶ Remove the power connector from the device.
- ▶ Press the device downwards.
- ▶ Pull it device from under the DIN rail.

6 Technical data

■ General technical data

Dimensions W × H × D	SPIDER Standard Line PoE	See "Dimension drawings" on page 28 .
Power supply	<ul style="list-style-type: none"> ▶ 2 voltage input ▶ 4-pin terminal block ▶ Safety extra-low voltage (SELV) 	
	Rated voltage range DC	24 V
	Voltage range DC incl. maximum tolerances	12 V ... 57 V
		SPIDER-SL-44-05T1... 7.3 A
		SPIDER-SL-44-08T1... 7.4 A
		SPIDER-SL-24... 7.4 A
	PoE power output	12 ... 18.9 V 60 W ¹ 19 ... 57 V 120 W ¹
	Power loss buffer	10 ms at 20.4 V DC (no PoE buffer)
	Back-up fuse	≤ 15 A, quick acting
	Peak inrush current	2.77 A ² s
Climatic conditions during operation	Ambient air temperature ²	-40 °C ... +70 °C (-40 °F ... +158 °F) Derating ³
	Humidity	10 % ... 95 % (non-condensing)
	Maximum Altitude	2000 m (6562 ft)
	Air pressure	minimum 795 hPa (+6562 ft; +2000 m)
Climatic conditions during storage	Ambient air temperature ²	-40 °C ... +85 °C (-40 °F ... +185 °F)
	Humidity	10 % ... 95 % (non-condensing)
	Air pressure	minimum 795 hPa (+6562 ft; +2000 m)
Pollution degree		2
Protection classes	Degree of protection	IP30

1. When the total PoE output power exceeds Max. PoE power output, the device stops working.

2. Temperature of the ambient air at a distance of 2 inches (5 cm) from the device.

3. Derating:

Vertical Installation -40 °C ... +65 °C at $U_{in} < 24$ VDC combined with PoE load > 90 W.

Horizontal Installation -40 °C ... +65 °C at $U_{in} < 24$ VDC combined with PoE load > 60 W.

-40 °C ... +60 °C at $U_{in} < 24$ VDC combined with PoE load > 90 W.

■ Dimension drawings

Figure 2: Dimensions of device variants SPIDER-SL-24...

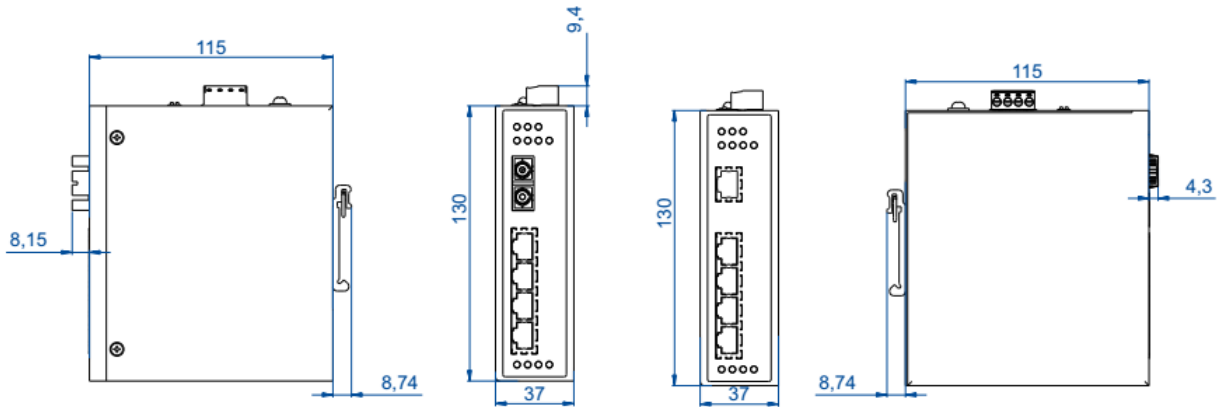
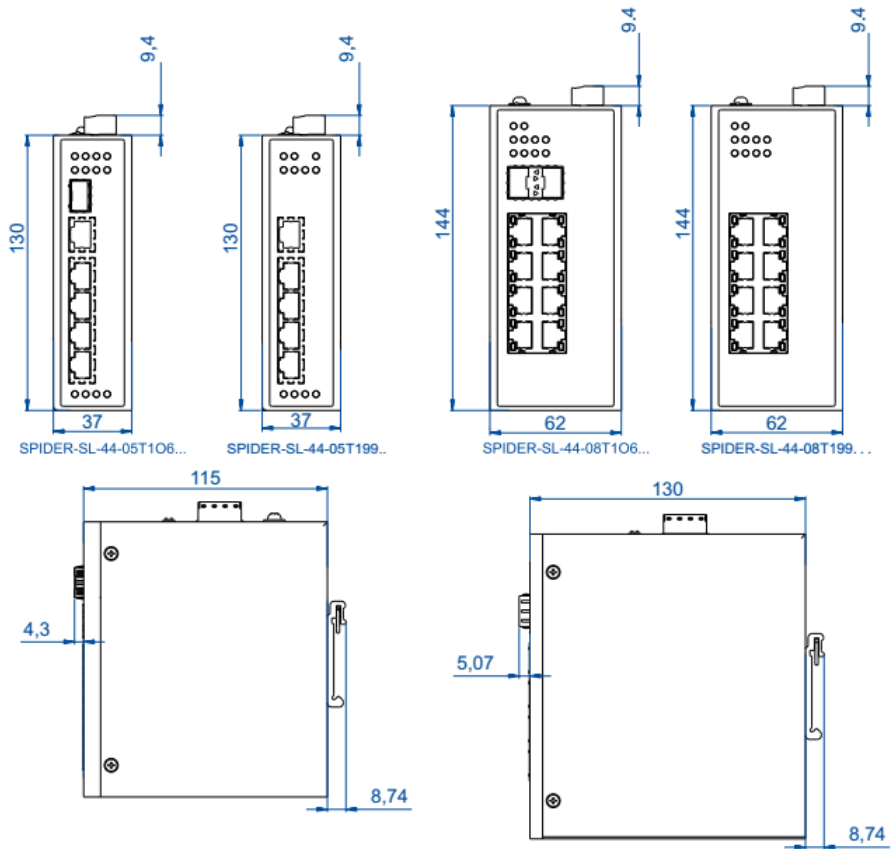

Figure 3: Dimensions of device variants SPIDER-SL-44...



■ EMC and immunity

EMC interference emission		
Radiated emission		
FCC 47 CFR Part 15		Class A
EN 55032		Class A
Conducted emission		
FCC 47 CFR Part 15		Class A
EN 55032		Class A

EMC interference immunity		
Electrostatic discharge		
EN 61000-4-2	Contact discharge	± 6 kV
IEEE C37.90.3		
EN 61000-4-2	Air discharge	± 8 kV
IEEE C37.90.3		
Electromagnetic field		
EN 61000-4-3	80 MHz ... 6000 MHz	10 V/m
Fast transients (burst)		
EN 61000-4-4	DC supply connection	± 2 kV
IEEE C37.90.1		
EN 61000-4-4	Data line	± 2 kV
IEEE C37.90.1		
Voltage surges - DC supply connection		
EN 61000-4-5	line/earth	± 2 kV
EN 61000-4-5	line/line	± 1 kV
Voltage surges - data line		
EN 61000-4-5	line/earth	± 1 kV
Conducted disturbances		
EN 61000-4-6	150 kHz ... 80 MHz	10 V

Stability		
IEC 60068-2-6, test Fc	Vibration	5 Hz ... 8.4 Hz with 3.5 mm amplitude
		8.4 Hz ... 150 Hz with 1 g
IEC 60068-2-27, test Ea	Shock	15 g at 11 ms

■ Network range

10/100/1000 Mbit/s twisted pair port	
Length of a twisted pair segment	max. 109 yards (100 m) (for Cat5e cable)

■ Scope of delivery

Number	Article
1 ×	Device
1 ×	4-pin, pluggable terminal block for power supply
1 ×	General safety instructions

■ Order number

Device	
SPIDER-SL-44-05T1O69999TY9HHHH	942-274-001
SPIDER-SL-44-05T1999999TY9HHHH	942-274-002
SPIDER-SL-44-08T1999999TY9HHHH	942-274-003
SPIDER-SL-44-08T1O6O699TY9HHHH	942-274-004
SPIDER-SL-24-04T1M29999TY9HHHH	942-274-005
SPIDER-SL-24-04T1M49999TY9HHHH	942-274-006
SPIDER-SL-24-04T1S29999TY9HHHH	942-274-007
SPIDER-SL-24-04T1S49999TY9HHHH	942-274-008
SPIDER-SL-24-05T1999999TRYHHHH	942-274-009

■ Accessories

Note that products recommended as accessories may have different characteristics to those of the device, which may limit the application range of the overall system. For example, if you add an accessory with IP20 to a device with IP65, the IP of the overall system is reduced to 20.

Fast-Ethernet-SFP-Transceiver	Order number
M-FAST SFP-MM/LC	943 865-001
M-FAST SFP-MM/LC EEC	943 945-001
M-FAST SFP-SM/LC	943 866-001
M-FAST SFP-SM/LC EEC	943 946-001
M-FAST SFP-SM+/LC	943 867-001
M-FAST SFP-SM+/LC EEC	943 947-001
M-FAST SFP-LH/LC	943 868-001
M-FAST SFP-LH/LC EEC	943 948-001
SFP-FAST-MM/LC ^a	942 194-001
SFP-FAST-MM/LC EEC ^a	942 194-002
SFP-FAST-SM/LC ^a	942 195-001
SFP-FAST-SM/LC EEC ^a	942 195-002

Bidirectional Gigabit Ethernet SFP transceiver	Order number
M-SFP-BIDI Type A LX/LC EEC	943 974-001
M-SFP-BIDI Type B LX/LC EEC	943 974-002
M-SFP-BIDI Type A LH/LC EEC	943 975-001
M-SFP-BIDI Type B LH/LC EEC	943 975-002
M-SFP-BIDI Bundle LX/LC EEC (type A + B)	943 974-101
M-SFP-BIDI Bundle LH/LC EEC (type A + B)	943 975-101

Gigabit Ethernet SFP transceiver	Order number
M-SFP-SX/LC	943 014-001
M-SFP-SX/LC EEC	943 896-001
M-SFP-LX/LC	943 015-001
M-SFP-LX/LC EEC	943 897-001
M-SFP-LX+/LC	942 023-001
M-SFP-LX+/ LC EEC	942 024-001
M-SFP-LH/LC	943 042-001
M-SFP-LH/LC EEC	943 898-001
M-SFP-LH+/LC	943 049-001
SFP-GIG-LX/LC ^a	942 196-001
SFP-GIG-LX/LC EEC ^a	942 196-002

- a. You will find further information on the certificates on the Internet on the Hirschmann product pages (www.doc.hirschmann.com).

Underlying technical standards

Name	
EN 55032	Information technology equipment – Radio disturbance characteristics – Limits and methods of measurement
EN 61000-6-2	Electromagnetic compatibility (EMC) – Part 6-2: Generic standards – Immunity for industrial environments
EN 61131-2	Programmable controllers – Part 2: Equipment requirements and tests
FCC 47 CFR Part 15	Code of Federal Regulations
UN/ECE No. 10	E type approval for use in vehicles.
UN/ECE No. 118	Burning behavior of materials used in motor vehicles.

Table 3: List of the technical standards

The device has an approval based on a specific standard only if the approval indicator appears on the device casing.

The device generally fulfills the technical standards named in their current versions.

A. Further Support

■ Technical Questions

For technical questions, please contact any Hirschmann dealer in your area or Hirschmann directly.

You will find the addresses of our partners on the Internet at <http://www.hirschmann.com>.

A list of local telephone numbers and email addresses for technical support directly from Hirschmann is available at

<https://hirschmann-support.belden.com>.

This site also includes a free of charge knowledge base and a software download section.

■ Hirschmann Competence Center

The Hirschmann Competence Center is ahead of its competitors:

- ▶ Consulting incorporates comprehensive technical advice, from system evaluation through network planning to project planning.
- ▶ Training offers you an introduction to the basics, product briefing and user training with certification.

The current technology and product training courses can be found at <http://www.hicomcenter.com>

- ▶ Support ranges from the first installation through the standby service to maintenance concepts.

With the Hirschmann Competence Center, you have decided against making any compromises. Our client-customized package leaves you free to choose the service components you want to use.

Internet:

<http://www.hicomcenter.com>