



HIRSCHMANN

A **BELDEN** BRAND

User Manual

Installation

Dragon PTN

Interface Module PTN-7-SERIAL

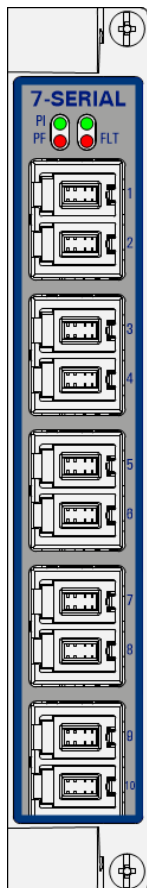

The naming of copyrighted trademarks in this manual, even when not specially indicated, should not be taken to mean that these names may be considered as free in the sense of the trademark and tradename protection law and hence that they may be freely used by anyone.

© 2019 Hirschmann Automation and Control GmbH

Manuals and software are protected by copyright. All rights reserved. The copying, reproduction, translation, conversion into any electronic medium or machine scannable form is not permitted, either in whole or in part. An exception is the preparation of a backup copy of the software for your own use.

The performance features described here are binding only if they have been expressly agreed when the contract was made. This document was produced by Hirschmann Automation and Control GmbH according to the best of the company's knowledge. Hirschmann reserves the right to change the contents of this document without prior notice. Hirschmann can give no guarantee in respect of the correctness or accuracy of the information in this document.

Hirschmann can accept no responsibility for damages, resulting from the use of the network components or the associated operating software. In addition, we refer to the conditions of use specified in the license contract.

You can get the latest version of this manual on the Internet at the Hirschmann product site (www.doc.hirschmann.com).

Hirschmann Automation and Control GmbH
Stuttgarter Str. 45-51
72654 Neckartenzlingen
Germany

Contents

1.	INTRODUCTION	6
1.1	General.....	6
1.2	Manual References	7
2.	MODULE DESCRIPTION	8
2.1	Front Panel And Connection Kits	8
2.1.1	Insert/Remove Module into/from Node	8
2.1.2	LEDs.....	8
2.1.3	RJ.5 Connector	9
2.1.4	RJ.5 Cable	10
2.1.5	Connection Kits	10
2.1.6	Signals per Serial Port	13
2.2	Functional Operation	14
2.2.1	General	14
2.2.2	Service Combination Examples per Interface Module	14
2.2.3	Port Interface Types	16
2.2.4	Serial Port Role DTE/DCE	16
2.2.5	Synchronization Parameter	16
2.2.6	Pin Layout Parameter	17
2.2.7	Services	17
2.2.8	CES: SAToP (Point-to-Point).....	18
2.2.9	CES: CESoPSN (Point-to-Point).....	18
2.2.10	CES: Hitless Switching	18
2.2.11	CES: Single Path	19
2.2.12	CES: Delay Comparison in CES Features	20
2.2.13	Serial Ethernet (Point-to-Multipoint)	21
2.2.14	Serial Ethernet: Master/Slave.....	21
2.2.15	Serial Ethernet: Advanced Mode - Bandwidth Optimization	21
2.2.16	Serial Ethernet: Multidrop Consistency.....	22
2.2.17	I/O with the Central Switching Module (=CSM)	22
2.2.18	Synchronization / Clock Distribution / Network Timing.....	22
2.2.19	Test and Loopback Selftests	25
2.3	Onboard Interfaces	25
2.3.1	Straps	25
2.3.2	DIP Switches	25
3.	TDM FRAMES/PACKET FOR CES	26
3.1	General.....	26
3.2	Bandwidth.....	26
3.3	Delay	27
3.3.1	General	27
3.3.2	Delay Parameters	27
3.3.3	Estimated Delay Calculation and Formulas	28
3.3.4	Estimated Delay Examples.....	28

3.3.5	Differential Delay	28
3.4	Tuning CES = Tuning TDM Frames/Packet	29
4.	MODULE SPECIFICATIONS	29
4.1	General Specifications.....	29
4.2	Other Specifications.....	29
4.3	Ordering Information.....	29
5.	ABBREVIATIONS	29

List of figures

Figure 1	Functional Overview Matrix	6
Figure 2	General PTN-7-SERIAL Example.....	7
Figure 3	Front Panel And Connection Kits.....	8
Figure 4	RJ.5 Connector.....	9
Figure 5	RJ.5 Cable/Pin Numbering/Color Coding.....	10
Figure 6	Example1	14
Figure 7	Example2	15
Figure 8	Example3	15
Figure 9	Example4	16
Figure 10	Hitless Switching.....	19
Figure 11	Single Path Enabled	20
Figure 12	Single Path Disabled	20
Figure 13	PTN-7-SERIAL Clocking/Synchronization Overview.....	23
Figure 14	PTN-7-SERIAL: Side View	25
Figure 15	Hardware Edition.....	26
Figure 16	CESoPSN Bandwidth	26
Figure 17	Delays	27
Figure 18	Differential Delay.....	28

List of Tables

Table 1	Manual References.....	7
Table 2	LED Indications In Boot Operation	8
Table 3	LED Indications In Normal Operation	9
Table 4	RJ.5 Cables to Serial Ports Mapping (Basic Kit).....	11
Table 5	RJ.5 Cables to Serial Ports Mapping (Extension Kit)	12
Table 6	Signals per Serial Port	13
Table 7	Difference Between Hitless and Protection Switching	19
Table 8	Delay Comparison in CES (Features).....	20
Table 9	Clocking Parameters on Port & Service Level.....	24
Table 10	Estimated Delay Formulas	28
Table 11	Estimated Delay (μ s) Examples.....	28
Table 12	Other Specifications.....	29

1. INTRODUCTION

1.1 General

This document is valid as of Dragon PTN Release 4.0DR.

This document describes the PTN-7-SERIAL interface module which provides 7 logical serial ports.

Depending on how the Interface Module is used, the amount of available serial ports varies from 4 to 7 per Interface Module. The matrix figure below indicates how many and which ports (Pn) can be used to transport the indicated protocol (RS232 (V.24)...) in the indicated mode (Asynchronous, Synchronous, Optimised, Full) in the indicated service (CES, Serial Ethernet). More information on all these modes and services can be found further on.

- ▶ **'CES'**: Circuit Emulation Service;
- ▶ **'X'**: this individual port can transport the indicated service;
- ▶ **'X combi'**: these two ports are required to transport the indicated service;
- ▶ **'spare'**: this individual port cannot transport the indicated service, though it can still be used to transport another service in the matrix, see §2.2.2 for some examples;
- ▶ A **point-to-multipoint** service (e.g. SCADA) requires a Serial Ethernet service;

See the figure below for an overview:

	RS232			RS422			RS485		X.21		V.35	
	Async (Serial Ethernet)	Async (CES)	Sync (CES)	Async (Serial Ethernet)	Async (CES)	Sync (CES)	Async (Serial Ethernet)	Async (CES)	Optimised (CES)	Full (CES)	Optimised (CES)	Full (CES)
P1	X	X	X	X	X	spare	X	X	X	spare	X	spare
P2	X	X	X	X	X	X combi	X	X	X	X combi	X	X combi
P3	X	spare	spare	X	spare		X	spare	spare		spare	
P4	X	X	X	X	X	X combi	X	X	X	X combi	X	X combi
P5	X	spare	spare	X	spare		X	spare	spare		spare	
P6	X	X	X	X	X	X combi	X	X	X	X combi	X	X combi
P7	X	spare	spare	X	spare		X	spare	spare		spare	

Figure 1 Functional Overview Matrix

Verify the 'Dragon PTN Bandwidth Overview' manual (Ref. [100] in Table 1) to see in which node and Interface Module slot this Interface Module can be used.

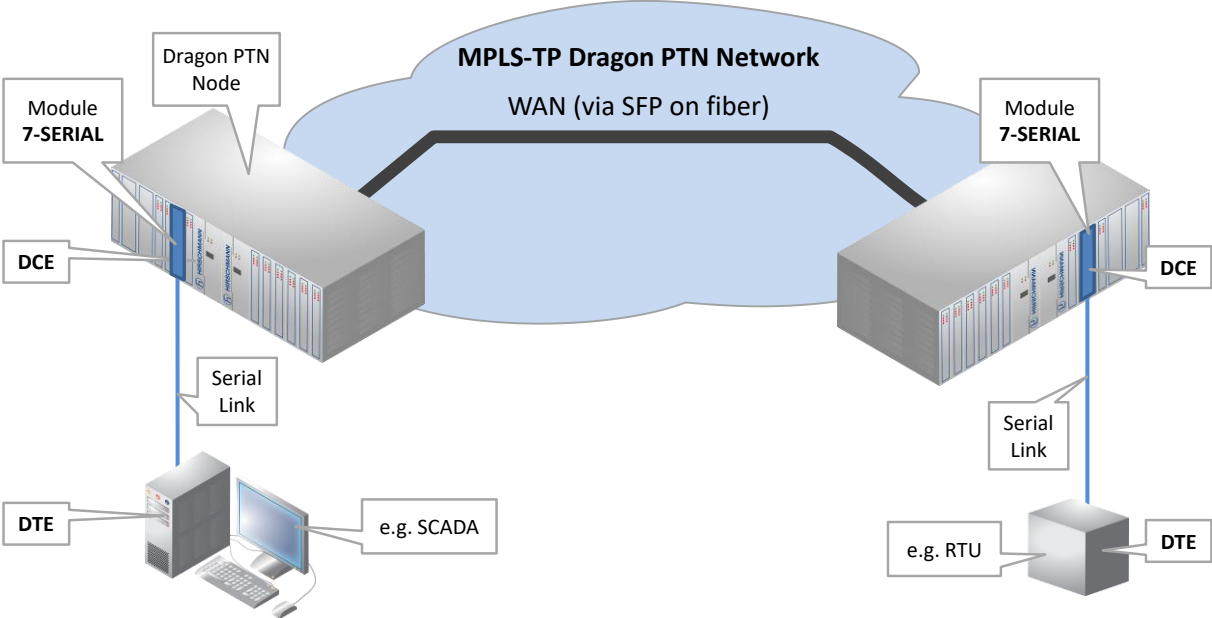

Figure 2 General PTN-7-SERIAL Example

1.2 Manual References

Table 1 is an overview of the manuals referred to in this manual. All these manuals can be found in the HiProvision (= Dragon PTN Management System) Help function.

Table 1 Manual References

Ref.	Manual	Title
[1]	UM_BasicConfig_Dragon-PTN_and_HiProvision-Operation_Rel_4-ODR_1019_en.pdf	Dragon PTN and HiProvision Operation
[2]	IG_Dragon-PTN_Installation-and-Operation_02_1019_en.pdf	Dragon PTN Installation and Operation
[4]	IG_Dragon-PTN_PTN-CSM310-A_02_1019_en.pdf	Dragon PTN Switching Module: PTN-CSM310-A
[5]	IG_Dragon-PTN_General-Specifications_01_1019_en.pdf	Dragon PTN General Specifications
[100]	UM_Dragon-PTN_Bandwidth-Overview_01_1019_en.pdf	Dragon PTN Bandwidth Overview

2. MODULE DESCRIPTION

2.1 Front Panel And Connection Kits

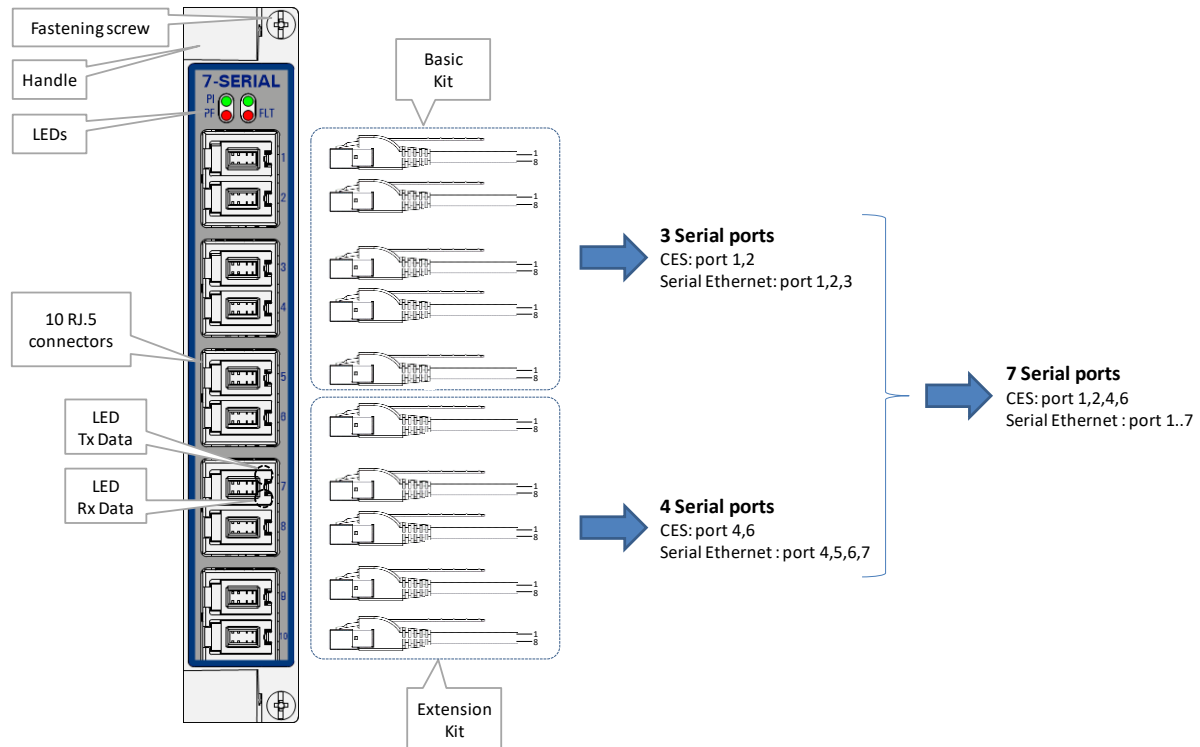

Figure 3 Front Panel And Connection Kits

2.1.1 Insert/Remove Module into/from Node

See 'Dragon PTN Installation and Operation Manual' Ref.[2].

2.1.2 LEDs

The meaning of the LEDs depends on the mode of operation (= boot or normal) in which the PTN-7-SERIAL module currently is running. After plugging in the module or rebooting it, the module turns into the boot operation, see Table 2. After the module has gone through all the cycles in the table below (=rebooted successfully), the module turns into the normal operation, see LEDs in Table 3.

Table 2 LED Indications In Boot Operation

Cycle	PI	PF	FLT	Tx Data[1..10]	Rx Data[1..10]
1	x	---	Slow blinking	---	---
2	x	---	Fast blinking	---	---
3	x	---	---	---	---
4	x	---	x	x red	x red
5	x	---	x	x green	x green

x : LED is lit / --- : LED is not lit; The sub cycle times may vary. The entire boot cycle time [1→5] takes approximately 2 minutes;

Table 3 LED Indications In Normal Operation

LED	Color	Status
PI (=Power Input)	Not lit, dark	+12V power input to the board not OK
	Green	+12V power input to the board OK
PF (=Power Failure)	Not lit, dark	power generation on the board itself is OK
	Red	power generation on the board itself is erroneous
FLT (=FauLT)	Not lit, dark	no other fault or error situation, different from PF, is active on the module
	Red	a fault or error situation, different from PF, is active on the module
Tx Data RJ.5 Connector 'x'	Not lit, dark	- No service programmed - Service programmed: 'Tx Data' is not active on serial port 'x'
	Green	Service programmed: 'Tx Data' is active on serial port 'x'
	Red	Service programmed but no data receiving from network, e.g. WAN link interrupted, destination Interface Module failure....
Rx Data RJ.5 Connector 'x'	Not lit, dark	- No service programmed - Service programmed: 'Rx Data' is not active on serial port 'x'
	Green	Service programmed: 'Rx Data' is active on serial port 'x'
	Red	Service programmed but no data receiving from network, e.g. WAN link interrupted, destination Interface Module failure....

2.1.3 RJ.5 Connector

This connector has 8 pins and 2 bi-color (green/red) LEDs, see figure below. For the meaning of the LEDs, see Table 3. The LEDs shown on connector 'x' show information of serial port 'x' although the pins of connector 'x' are not necessarily pins of serial port 'x' (see Table 4, Table 5). Example:

- ▶ RJ.5 connector 1 LEDs show information of serial port 1;
- ▶ RJ.5 connector 2 LEDs show information of serial port 2; etc.....
- ▶ RJ.5 connector 8, 9, 10 LEDs are only lit during the self-test in the boot cycle (see Table 2) but have no further meaning.

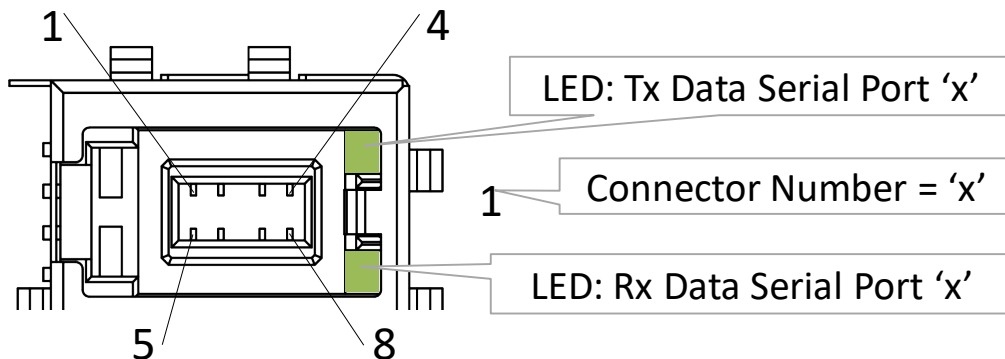

Figure 4 RJ.5 Connector

2.1.4 RJ.5 Cable

Each connection kit has five RJ.5 cables. This cable is very suited for high density cabling compared to traditional RJ45 cables. The RJ.5 cables in the connection kits are open end, with the color coding of the wires as indicated in the figure below. WH = white; OG = Orange; GN = Green; BU = Blue; BN = Brown; When a cable is plugged into the RJ.5 connector on the front panel and must be disconnected, remove the connector by pulling out the unlock handle.

The cable connector has little holes which allow the LED light from the front panel RJ.5 connector to shine through, after the cable has been plugged in.

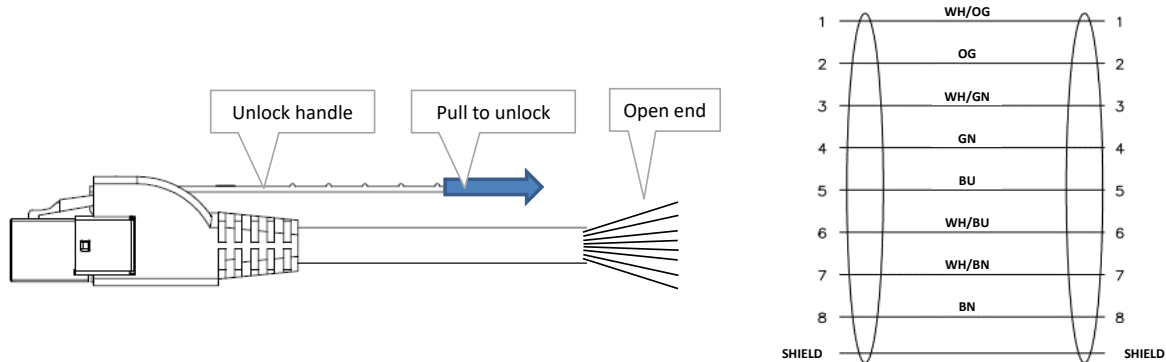

Figure 5 RJ.5 Cable/Pin Numbering/Color Coding

2.1.5 Connection Kits

The PTN-7-SERIAL module provides 10 RJ.5 connectors on the front with each connector 8 pins. As a result, a total of 80 pins are used to provide 7 serial ports that are wired out via 2 connection kits. The table below lists a mapping between the front panel connectors and the 7 serial ports; The signals available on the serial port pins depend on the port interface type, see §2.2.1.

a. Basic Kit

The Basic kit (order n° 942 256-300) must be used to wire out serial port 1, 2 and 3. This kit includes 5 open end RJ.5 cables of 3 meter marked from 1 to 5. This kit must be connected to connector [1→5] on the front panel;

b. Extension Kit

The Extension kit (order n° 942 256-301) must be used to wire out serial port 4, 5, 6 and 7. This kit includes 5 open end RJ.5 cables of 3 meter marked from 6 to 10. This kit must be connected to connector [6→10] on the front panel;

Table 4 RJ.5 Cables to Serial Ports Mapping (Basic Kit)

Cable Kit	RJ.5 Cable	RJ.5 Pin n°	Color	Serial Port – Pin n°
Basic Kit	1	1	WH/OG	1-1
		2	OG	1-2
		3	WH/GN	1-3
		4	GN	1-4
		5	BU	1-5
		6	WH/BU	1-6
		7	WH/BN	1-7
		8	BN	1-8
	2	1	WH/OG	1-9
		2	OG	1-10
		3	WH/GN	GND
		4	GN	GND
		5	BU	GND
		6	WH/BU	GND
		7	WH/BN	GND
		8	BN	GND
	3	1	WH/OG	2-1
		2	OG	2-2
		3	WH/GN	2-3
		4	GN	2-4
		5	BU	2-5
		6	WH/BU	2-6
		7	WH/BN	2-7
		8	BN	2-8
	4	1	WH/OG	2-9
		2	OG	2-10
		3	WH/GN	3-1
		4	GN	3-2
		5	BU	3-3
		6	WH/BU	3-4
		7	WH/BN	3-5
		8	BN	3-6
	5	1	WH/OG	GND
		2	OG	Frame GND
		3	WH/GN	Frame GND
		4	GN	Frame GND
		5	BU	3-7
		6	WH/BU	3-8
		7	WH/BN	3-9
		8	BN	3-10

Table 5 RJ.5 Cables to Serial Ports Mapping (Extension Kit)

Cable Kit	RJ.5 Cable	RJ.5 Pin n°	Color	Serial Port – Pin n°
Extension Kit	6	1	WH/OG	4-1
		2	OG	4-2
		3	WH/GN	4-3
		4	GN	4-4
		5	BU	4-5
		6	WH/BU	4-6
		7	WH/BN	4-7
		8	BN	4-8
	7	1	WH/OG	4-9
		2	OG	4-10
		3	WH/GN	5-1
		4	GN	5-2
		5	BU	5-3
		6	WH/BU	5-4
		7	WH/BN	5-5
		8	BN	5-6
	8	1	WH/OG	6-1
		2	OG	6-2
		3	WH/GN	6-3
		4	GN	6-4
		5	BU	6-5
		6	WH/BU	6-6
		7	WH/BN	6-7
		8	BN	6-8
	9	1	WH/OG	6-9
		2	OG	6-10
		3	WH/GN	7-1
		4	GN	7-2
		5	BU	7-3
		6	WH/BU	7-4
		7	WH/BN	7-5
		8	BN	7-6
10	1	WH/OG	5-7	
	2	OG	5-8	
	3	WH/GN	5-9	
	4	GN	5-10	
	5	BU	7-7	
	6	WH/BU	7-8	
	7	WH/BN	7-9	
	8	BN	7-10	

2.1.6 Signals per Serial Port

An individual serial port ('X' in Figure 1) has 11 pins whereas a combined serial port ('X combi' in Figure 1) has 22 pins. See table below.

In RS232 (V.24), RS422, X.21, V.35: Pin 9, 10, 20 and 21 are bidirectional pins. If the signal is available, the pin is output in DTE and input in DCE.

Table 4 and Table 5 shows where all these pins are outputted via the basic and extension kit.

Table 6 Signals per Serial Port

Serial Port n°	Pin n°	In/ Out	RS232 (V.24)				RS422				RS485	X.21				V.35			
			Asynchronous		Synchronous		Asynchronous		Synchronous		Asynchronous	Optimised		Full		Optimised		Full	
			DTE	DCE	DTE	DCE	DTE	DCE	DTE	DCE		DTE	DCE	DTE	DCE	DTE	DCE	DTE	DCE
n	1	Out1+	TxD	RxD	TxD	RxD	TxDb	RxDb	TxDb	RxDb	Tri-state	TxDb	RxDb	TxDb	RxDb	TxDb	RxDb	TxDb	RxDb
	2	Out1-	RTS	CTS	RTS	CTS	TxDa	RxDa	TxDa	RxDa	Tri-state	TxDa	RxDa	TxDa	RxDa	TxDa	RxDa	TxDa	RxDa
	3	In1+	RxD	TxD	RxD	TxD	RxDb	TxDb	RxDb	TxDb	---	RxDb	TxDb	RxDb	TxDb	RxDb	TxDb	RxDb	TxDb
	4	In1-	CTS	RTS	CTS	RTS	RxDa	TxDa	RxDa	TxDa	---	RxDa	TxDa	RxDa	TxDa	RxDa	TxDa	RxDa	TxDa
	5	Out2+	---	---	TTC	RxC	RTSb	CTSb	TTCb	RxCb	Tri-state	Cb	lb	Cb	lb	TTCb	RxCb	TTCb	RxCb
	6	Out2-	DTR	DSR	DTR	DSR	RTSa	CTSa	TTCa	RxCa	Tri-state	Ca	la	Ca	la	TTCa	RxCa	TTCa	RxCa
	7	In2+	---	---	RxC	TTC	CTSb	RTSb	RxCb	TTCb	---	lb	Cb	lb	Cb	RxCb	TTCb	RxCb	TTCb
	8	In2-	DSR	DTR	DSR	DTR	CTSa	RTSa	RxCa	TTCa	---	la	Ca	la	Ca	RxCa	TTCa	RxCa	TTCa
	9	In3/Out3+	---	---	TxC(In)	TXC(Out)	DCDb(In)	DCDb(Out)	TxCb(In)	TXCb(Out)	TRxDb	Sb(In)	Sb(Out)	Sb(In)	Sb(Out)	TxCb(In)	TXCb(Out)	TxCb(In)	TXCb(Out)
	10	In3/Out3-	DCD(In)	DCD(Out)	DCD(In)	DCD(Out)	DCDa(In)	DCDa(Out)	TxCa(In)	TXCa(Out)	TRxDa	Sa(In)	Sa(Out)	Sa(In)	Sa(Out)	TxCa(In)	TXCa(Out)	TxCa(In)	TXCa(Out)
	11	GND	GND	GND	GND	GND	GND	GND	GND	GND	GND	GND	GND	GND	GND	GND	GND	GND	GND
n+1 (=combi)	1	Out1+							RTSb	CTSb				Xb	Bb			---	---
	2	Out1-							RTSa	CTSa				Xa	Ba			RTS	CTS
	3	In1+							CTSb	RTSb				Bb	Xb			---	---
	4	In1-							CTSa	RTSa				Ba	Xa			CTS	RTS
	5	Out2+							DTRb	DSRb				---	---			---	---
	6	Out2-							DTRa	DSRa				---	---			DTR	DSR
	7	In2+							DSRb	DTRb				---	---			---	---
	8	In2-							DSRa	DTRa				---	---			DSR	DTR
	9	In3/Out3+							DCDb(In)	DCDb(Out)				---	---			---	---
	10	In3/Out3-							DCDa(In)	DCDa(Out)				---	---			DCD(In)	DCD(Out)
	11	GND							GND	GND				GND	GND			GND	GND

2.2 Functional Operation

2.2.1 General

Depending on how the Interface Module is used, the amount of available serial ports varies from 4 to 7 per Interface Module. See Figure 1 for an overview matrix. The figure indicates how many and which ports (Pn) can be used to transport the indicated protocol (RS232 (V.24)...) in the indicated mode (Asynchronous, Synchronous, Optimised, Full) in the indicated service (CES, Serial Ethernet).

- ▶ Functional overview matrix, see Figure 1;
- ▶ Service Combination Examples per Interface Module: see §2.2.2;
- ▶ Supported interface types or protocols: see §2.2.3;
- ▶ Port role DTE/DCE: see §2.2.4;
- ▶ Synchronization parameter (Asynchronous/Synchronous): see §2.2.5;
- ▶ Pin Layout parameter (Full/Optimised): see §2.2.6;
- ▶ Services (CES/Serial Ethernet): see §2.2.7;

2.2.2 Service Combination Examples per Interface Module

The figures below show some examples how the transport of different serial services can be -combined on one PTN-7-SERIAL Interface Module. All the examples below have all the 7 serial ports in use. A green highlighted box indicates a used port for the indicated service.

Example1:

- ▶ Transports 4 services in total;
- ▶ P1 transports an Asynchronous RS232 (V.24) protocol via a Serial Ethernet service.
- ▶ P2+P3 transports a Full V.35 protocol via a CES service;
- ▶ P4+P5 transports a Full V.35 protocol via a CES service;
- ▶ P6+P7 transports a Full V.35 protocol via a CES service;

3*V.35 (Full) + 1*RS232 Async

	RS232			RS422			RS485		X.21		V.35	
	Async (Serial Ethernet)	Async (CES)	Sync (CES)	Async (Serial Ethernet)	Async (CES)	Sync (CES)	Async (Serial Ethernet)	Async (CES)	Optimised (CES)	Full (CES)	Optimised (CES)	Full (CES)
P1	X	X	X	X	X	spare	X	X	X	spare	X	spare
P2	X	X	X	X	X	X combi	X	X	X	X combi	X	X combi
P3	X	spare	spare	X	spare		X	spare	spare		spare	
P4	X	X	X	X	X	X combi	X	X	X	X combi	X	X combi
P5	X	spare	spare	X	spare		X	spare	spare		spare	
P6	X	X	X	X	X	X combi	X	X	X	X combi	X	X combi
P7	X	spare	spare	X	spare		X	spare	spare		spare	

Figure 6 Example1

3*RS232 Sync + 4*RS422 Async

	RS232			RS422			RS485		X.21		V.35	
	Async (Serial Ethernet)	Async (CES)	Sync (CES)	Async (Serial Ethernet)	Async (CES)	Sync (CES)	Async (Serial Ethernet)	Async (CES)	Optimised (CES)	Full (CES)	Optimised (CES)	Full (CES)
P1	X	X	X	X	X	spare	X	X	X	spare	X	spare
P2	X	X	X	X	X	X combi	X	X	X	X combi	X	X combi
P3	X	spare	spare	X	spare		X	spare	spare		spare	
P4	X	X	X	X	X	X combi	X	X	X	X combi	X	X combi
P5	X	spare	spare	X	spare		X	spare	spare		spare	
P6	X	X	X	X	X	X combi	X	X	X	X combi	X	X combi
P7	X	spare	spare	X	spare		X	spare	spare		spare	

Figure 7 Example2

2*V.35 (Full) + 1*RS232 Async + 2*RS422 Async

	RS232			RS422			RS485		X.21		V.35	
	Async (Serial Ethernet)	Async (CES)	Sync (CES)	Async (Serial Ethernet)	Async (CES)	Sync (CES)	Async (Serial Ethernet)	Async (CES)	Optimised (CES)	Full (CES)	Optimised (CES)	Full (CES)
P1	X	X	X	X	X	spare	X	X	X	spare	X	spare
P2	X	X	X	X	X	X combi	X	X	X	X combi	X	X combi
P3	X	spare	spare	X	spare		X	spare	spare		spare	
P4	X	X	X	X	X	X combi	X	X	X	X combi	X	X
P5	X	spare	spare	X	spare		X	spare	spare		spare	spare
P6	X	X	X	X	X	X combi	X	X	X	X combi	X	X
P7	X	spare	spare	X	spare		X	spare	spare		spare	spare

Figure 8 Example3

4*X.21 Optimised + 3*RS232 Async

	RS232			RS422			RS485		X.21		V.35	
	Async (Serial Ethernet)	Async (CES)	Sync (CES)	Async (Serial Ethernet)	Async (CES)	Sync (CES)	Async (Serial Ethernet)	Async (CES)	Optimised (CES)	Full (CES)	Optimised (CES)	Full (CES)
P1	X	X	X	X	X	spare	X	X	X	spare	X	spare
P2	X	X	X	X	X	X combi	X	X	X	X combi	X	X combi
P3	X	spare	spare	X	spare		X	spare	spare		spare	
P4	X	X	X	X	X	X combi	X	X	X	X combi	X	X combi
P5	X	spare	spare	X	spare		X	spare	spare		spare	
P6	X	X	X	X	X	X combi	X	X	X	X combi	X	X combi
P7	X	spare	spare	X	spare		X	spare	spare		spare	

Figure 9 Example4

2.2.3 Port Interface Types

Each serial port can be configured via HiProvision (= Dragon PTN Management System) in one of the interface types listed below. This setting occurs at service creation. As a result, both end points or ports will have the same setting after the service creation.

- ▶ RS232 (V.24) / RS422 / RS485 / X.21 / V.35;

2.2.4 Serial Port Role DTE/DCE

For the protocols RS232 (V.24), RS422, X.21, V.35, each serial port can be configured via HiProvision in the port role DTE or DCE. By default, when a service is configured on a port, its port role is set automatically to DCE. If it must be changed to DTE, it must be done later on via changing the port settings in the Network Hardware tab.

- ▶ DTE (=Data Terminal Equipment): Example: PC, RTU, terminal, printer, etc.
- ▶ DCE (=Data Communication Equipment): modems etc.

NOTE: Not relevant for RS485;

2.2.5 Synchronization Parameter

- ▶ **Synchronous:** both the transmitter and receiver use a clock to exchange data. The clock is transmitted over the network as well;
- ▶ **Asynchronous:** no clock is exchanged between the transmitter and receiver. Only data is exchanged. Both the transmitter and receiver use start and stop bits to indicate the start and stop of data;

2.2.6 Pin Layout Parameter

This parameter is only relevant for X.21 and V.35. See Table 6.

- ▶ **Full:** indicates that all protocol signals are fully supported and transported. As a result, this service requires a combi port 'X combi';
- ▶ **Optimised:** indicates an optimised pin layout of the available protocol signals. It means that only the essential signals are transported. As a result, this service only requires one port 'X', which leaves some spare ports to transport other protocols;
 - ▶ X.21: One clock and all control signals are transmitted;
 - ▶ V.35: All three clocks are transmitted, but not the control signals;

2.2.7 Services

Serial communication can be configured in HiProvision via creating a CES or Serial Ethernet Service.

- ▶ **CES (=Circuit Emulation Service) - Serial:** use this service when **Point-to-Point** is needed. Serial data will be encapsulated in TDM packets which will be sent over the Dragon PTN network as Ethernet packets.
- ▶ **Serial Ethernet:** use this service when **Point-to-Multipoint** (e.g. SCADA) is needed. Serial data will be encapsulated directly into Ethernet packets and sent over the Dragon PTN network. All 7 ports can transport such a service. Master(s)/slave(s) must be configured in this service.

Following parameters are needed per service:

- ▶ CES: Service Type: Circuit Emulation;
 - ▶ Protocol: Serial;
 - ▶ SAToP/CESoPSN;
 - ▶ optional: Hitless Switching;
 - ▶ optional: Single Path;
 - ▶ Synchronization: Synchronous/Asynchronous;
 - ▶ Interface Type:
 - ▶ Asynchronous: RS232 (V.24)/RS422/RS485;
 - ▶ Synchronous: RS232 (V.24)/RS422/X.21/V.35;
 - ▶ Bitrate;
 - ▶ Pin Layout: Full/Optimised
- ▶ Serial Ethernet: Service Type: Serial Ethernet;
 - ▶ (Always Asynchronous)
 - ▶ Interface Type: RS232 (V.24)/RS422/RS485;
 - ▶ Bitrate;
 - ▶ Stop Bits;
 - ▶ Data Bits;
 - ▶ Parity;
 - ▶ Master(s)/Slave(s) selection;

2.2.8 CES: SAToP (Point-to-Point)

SAToP (=Structure Agnostic TDM over Packet) is a point-to-point service between two serial ports. The serial data will be packetized in an E1 frame, using all 32 timeslots, over the Dragon PTN network. As a result, maximum one SAToP service can be configured per port.

This way of transportation consumes more bandwidth over the Dragon PTN network than CESoPSN (see next paragraph), but has less differential delay than CESoPSN. If delay must be as low as possible, use SAToP instead of CESoPSN to transport your PTN-7-SERIAL data.

NOTE: Each end-point or PTN-7-SERIAL port must be located in a different node. Future: end-points can also be located intra-module or intra-node.

2.2.9 CES: CESoPSN (Point-to-Point)

CESoPSN (=Circuit Emulation Service over Packet Switched Network) is a point-to-point service between two serial ports. One such service can be configured per port. This service converts the incoming serial data into an amount of timeslots, to transport it over the MPLS-TP Dragon PTN network. The amount of timeslots over the network just depends on the selected bit rate.

The destination module will receive the transported timeslots from the Dragon PTN network and regenerate the serial data from it. As a result, the destination sends out the regenerated serial data on its serial port.

Each end-point or port must be located in a different node.

2.2.10 CES: Hitless Switching

Hitless Switching is a feature within CESoPSN that provides a safe redundant connection where no data or synchronization is lost when switching from the active to the backup path or vice versa, e.g. because of cable break. The total delay over the network remains nearly constant during switch-over. Redundancy via Hitless Switching is obtained via completing the list below:

- ▶ creating two independent point-to-point tunnels without protection;
- ▶ setting the Hitless Switching on at service creation time in HiProvision.

NOTE: See Ref.[1] for the creation of tunnels and services;

On the source side, with Hitless Switching enabled, the Interface Module duplicates each packet on a second tunnel (e.g. Tunnel y, see figure below). Each packet also contains a 16 bit sequence number. Different tunnels mean different paths through the network, with each path its own delay. Different delays result in a slow and a fast path.

On the destination side, with Hitless Switching enabled, the Interface Module buffers the fastest path and forwards packets from the slowest path on the serial link. Packets will be processed according a packet sequence number.

Hitless Switching is a redundant mechanism but differs from Protection Switching, see the table below for an overview. So if redundancy is needed in the service, either choose Hitless Switching or Protection Switching, mixing up both mechanisms is not allowed. Depending on the choice, settings must be done at tunnel creation time and/or service creation time.

When Hitless Switching has been enabled, the CES can only start up with two links up, coming out of a two-links-down situation (except when Single Path has been enabled, see §2.2.11). See §2.2.12 for a delay comparison within CES depending on the enabled sub features, see also further on.

Table 7 Difference Between Hitless and Protection Switching

	Protection Switching	Hitless Switching
required tunnel type	1 point-to-point tunnel	2 point-to-point tunnels
tunnel protection type	1:1;	none; the redundancy is created via two independent point-to-point tunnels.
service parameter	Hitless Switching = disabled	Hitless Switching = enabled
at switch-over	possible data loss	no data or synchronization loss
total delay	less than hitless switching	more than protection switching

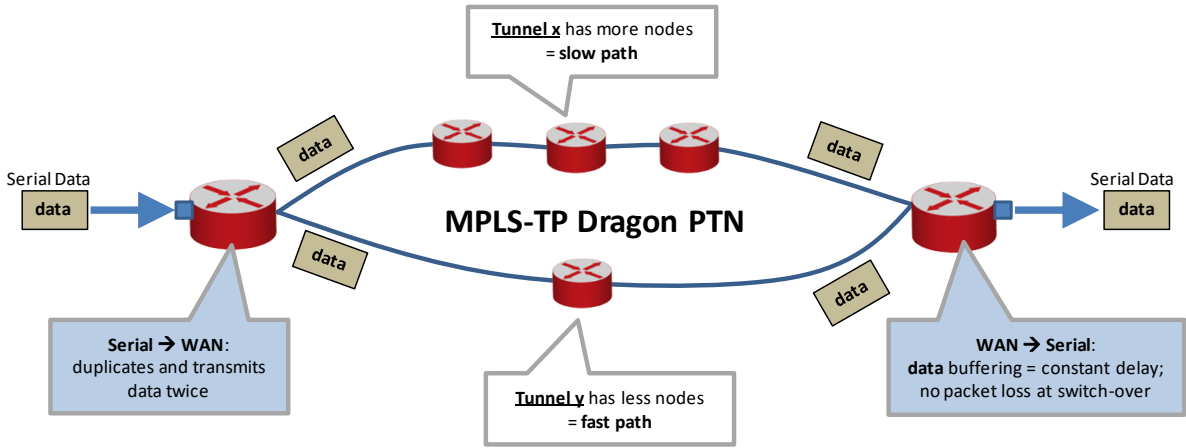

Figure 10 Hitless Switching

2.2.11 CES: Single Path

The Single Path feature is a sub feature of Hitless Switching (see §2.2.10). It influences the start-up behavior of the Hitless Switching mechanism:

- ▶ enabled: The CES can already start up with only one link up, coming out of a two-links-down situation; this setting results in bigger delays because of bigger buffers.
 - ▶ if the fastest path came up first:
 - ▶ the CES starts up according to the fastest path;
 - ▶ possible CES interrupt or minor packet loss when the slowest path comes up later on;
 - ▶ if the slowest path came up first:
 - ▶ the CES starts up according to the slowest path;
 - ▶ no CES interrupt or packet loss when the fastest path comes up later on;

See §2.2.12 for a delay comparison within CES depending on the enabled sub features, see also further on.

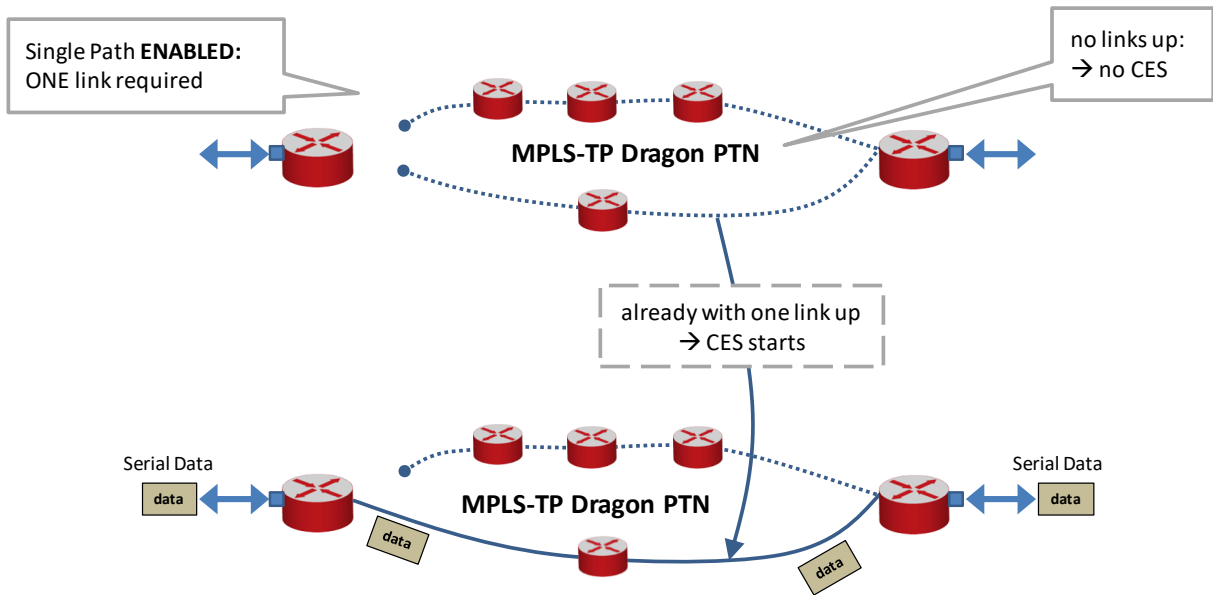

Figure 11 Single Path Enabled

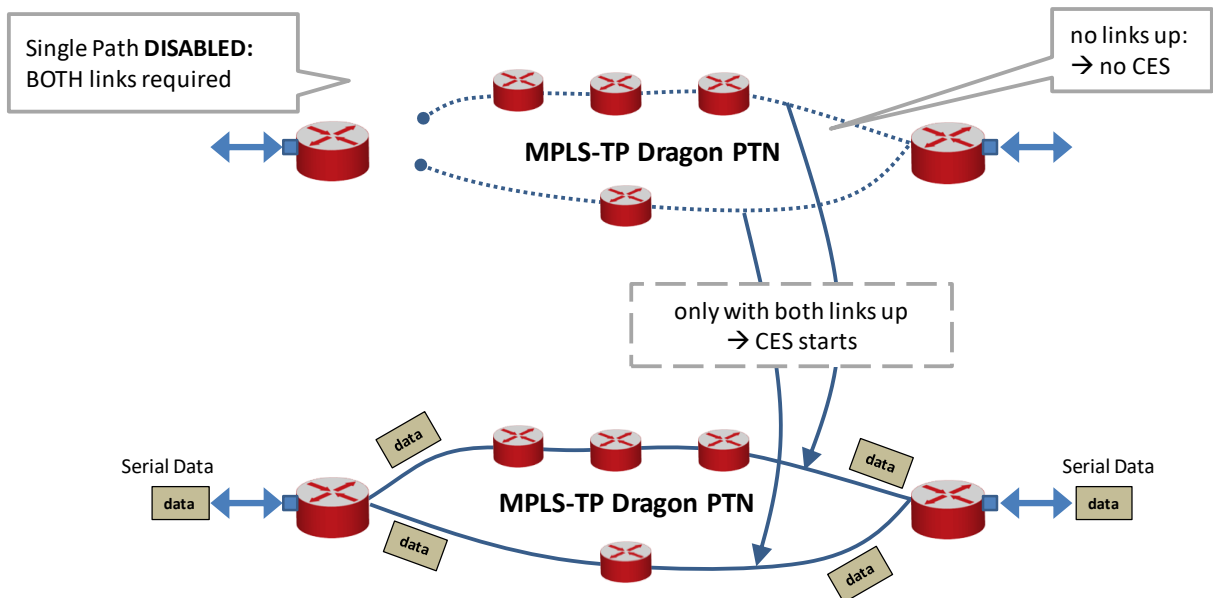

Figure 12 Single Path Disabled

2.2.12 CES: Delay Comparison in CES Features

Table 8 Delay Comparison in CES (Features)

CES	Hitless Switching	Single Path	Resulting Delay
X	---	---	lowest
X	X	---	medium
X	X	X	highest

X = enabled; --- = disabled

2.2.13 Serial Ethernet (Point-to-Multipoint)

Serial Ethernet is a point-to-multipoint service between two or more serial ports, e.g. for SCADA systems. One such service can be configured per port. This service converts the incoming serial data directly into Ethernet packets, to transport it over the MPLS-TP Dragon PTN network.

The destination module will receive the Ethernet packets from the Dragon PTN network and regenerate the serial data from it. As a result, the destination sends out the regenerated serial data on its serial port.

At least two nodes are required and each node can have multiple end-points of that service.

2.2.14 Serial Ethernet: Master/Slave

A Serial Ethernet Service is typically used for a point-to-multipoint service, e.g. SCADA systems. In this service, at least one master (maximum two masters) and one or more slaves (maximum 156 slaves) must be selected.

When two masters are selected, one of them will be the active one and the other one will be the backup master. Which one is the active/backup master will be decided by the serial protocol itself.

The (active) master will initiate commands or requests to their slaves. The backup master and all the slaves will see this request. Only the addressed slave will process the request and send a response back to the (active) master. The backup master and all the other slaves will see the slave response.

Only the (active) master will process the slave response. The backup master (if any) will be synchronized with the active master and will take over when the active master gets out of service.

2.2.15 Serial Ethernet: Advanced Mode - Bandwidth Optimization

At service creation, fine-tuning the bandwidth and delay through the network is done via the Advanced Mode parameter. It groups payload data more efficiently in the transmit process resulting in less overhead. Note that less bandwidth results in more delay and vice versa.

Serial data is collected at the front ports and buffered until one of the events below is triggered. After the trigger, the payload data is packetized and sent over the Dragon PTN network.

- ▶ Amount of payload bytes received at the front (Fixed Block size);
- ▶ Periodic transmit timer expires (Fixed Transmit Timer);
- ▶ Detection of a line termination character (Delimiter: Line Termination Character);
- ▶ Timeout occurs after the last received byte (Delimiter Timeout);

See the HiProvision manual for more info: Ref.[1] in Table 1;

2.2.16 Serial Ethernet: Multidrop Consistency

Multidrop Consistency is a polling mechanism, within a Serial Ethernet service, between the master(s) Interface Module(s) and the slave Interface Modules to check whether the slave Interface Modules are still alive. The master Interface Module is the Interface Module connected to the master application, the slave Interface Module is the Interface Module connected to the slave application.

When the feature is activated in HiProvision, the polling occurs every 500 ms. If a polling failure occurs, the necessary alarms will be raised. Deactivate the feature to stop the polling.

More info in the HiProvision manual Ref.[1] in Table 1;

2.2.17 I/O with the Central Switching Module (=CSM)

The PTN-7-SERIAL module receives traffic via its front panel ports and converts this into Ethernet traffic which is forwarded to the CSM via the backplane. The CSM does all the processing on this data (synchronization, CRC checks, conversions, switching...).

The CSM converts this data into MPLS-TP packets and transmits it via a WAN port (on an Interface Module that supports WAN) onto the WAN. On the destination side, the same processing occurs in reverse order.

See the manuals in Ref.[4],[4b] in Table 1 for more information.

2.2.18 Synchronization / Clock Distribution / Network Timing

CAUTION: Make sure to configure/verify the clocking parameters below.

The Dragon PTN network provides a number of mechanisms to perform synchronization / clock distribution / network timing per CES. The CSM synchronizes all the included Interface Modules in the node.

The application endpoints in a 'Circuit Emulation: Serial' service can communicate in a synchronized way. Which method can be used depends on:

- ▶ the 'Clock source' port setting of the two endpoints;
- ▶ SyncE availability in the endpoint nodes;

The figure below show relevant end-to-end clocking configurations for the Synchronous and Asynchronous variants. The Dragon PTN network can act as a wire or a DCE. DTE/DCE roles are indicated as well.

The PRC (=Primary Reference Clock) is a very stable high quality clock that can be used as a reference clock delivered via SyncE to the node:

- ▶ A, D = Application ports;
- ▶ B, C = Interface Module front ports;

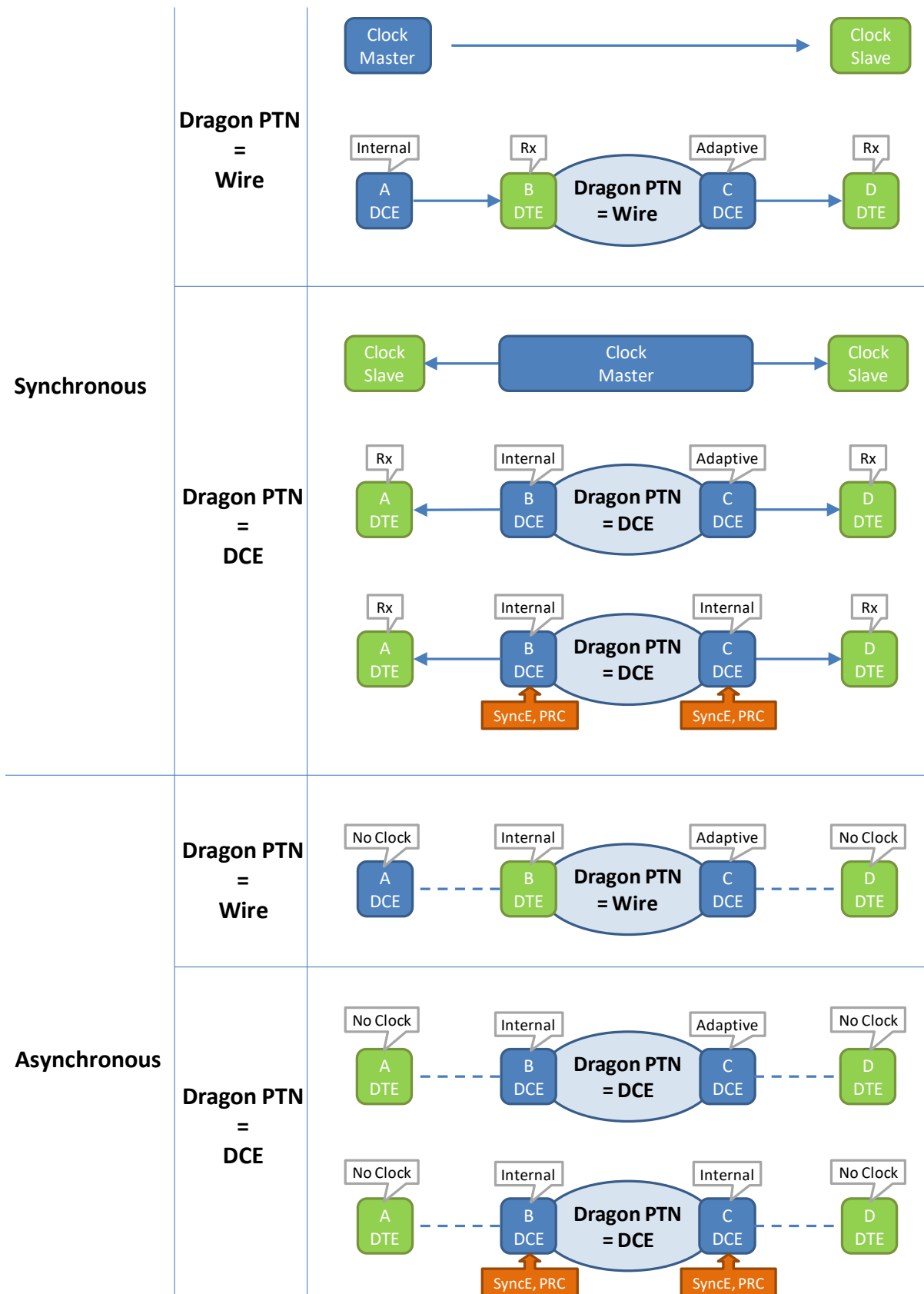

Figure 13 PTN-7-SERIAL Clocking/Synchronization Overview

Table 9 Clocking Parameters on Port & Service Level

Port A: Clock Source	Port B: Clock Source	Port C: Clock Source	Port D: Clock Source	Description
<u>Synchronous, Wire: Application D slaves to application A via Dragon PTN</u>				
'Internal Clock'	'Rx Clock'	' <u>Adaptive/ Differential</u> '	'Rx Clock'	<p>Node (B) recovers the clock from the incoming data stream from Application (A) and uses it to decode/encode the packet stream.</p> <p>Node (C) recovers the clock from the incoming packet stream from the network and uses it to encode/decode the data stream. Application (D) slaves its clock to this stream.</p>
<u>Synchronous, DCE: Both Applications A and D slave to Dragon PTN Clock Master</u>				
'Rx Clock'	'Internal Clock'	' <u>Adaptive/ Differential</u> '	'Rx Clock'	<p>Node (B) transmits packets to node (C) based on an Internal Clock. This clock is delivered by the local oscillator on the Interface Module. Node (C) recovers the clock from the incoming packet stream from the network and uses it to encode/decode data streams.</p> <p>Both applications (A) and (D) slave their clock to the data streams delivered by node (B) and (C).</p>
'Rx Clock'	'Internal Clock' + SyncE	'Internal Clock' + SyncE	'Rx Clock'	<p>Both nodes (B) and (C) encode/decode the data stream to/from the end applications based on the 'Internal Clock' on the Interface Module. This clock is delivered by the CSM and is based on a PRC delivered via SyncE.</p> <p>Both applications (A) and (D) slave their clock to the data streams delivered by node (B) and (C).</p>
<u>Asynchronous (Applications are not synchronized to Dragon PTN or vice versa)</u>				
'No Clock'	'Internal Clock'	' <u>Adaptive/ Differential</u> '	'No Clock'	<p>Node (B) transmits packets to node (C) based on an Internal Clock. This clock is delivered by the local oscillator on the Interface Module. Node (C) recovers the clock from the incoming packet stream from the network and uses it to encode/decode data streams.</p>
'No Clock'	'Internal Clock' + SyncE	'Internal Clock' + SyncE	'No Clock'	<p>Both nodes (B) and (C) encode/decode the data stream to/from the end applications based on the 'Internal Clock' on the Interface Module. This clock is delivered by the CSM and is based on a PRC delivered via SyncE.</p>

NOTE: SyncE: See the manuals in Ref.[1] and Ref.[4],[4b] for more detailed information;

2.2.19 Test and Loopback Selftests

Test and Loopback selftests can be performed in CESes, e.g. when configuring or troubleshooting a CES. Following two functions can be used in a programmed CES:

- ▶ Loopbacks: on backplane or front port, direction towards line (=application) or network can be configured;
- ▶ BERT: test traffic generation and verification via Bit Error Ratio Tester.

CAUTION: enabling selftests disables or disturbs normal service traffic on a port!

For more information and configuration settings, see 'Test and Loopback' in Ref.[1] in Table 1.

2.3 Onboard Interfaces

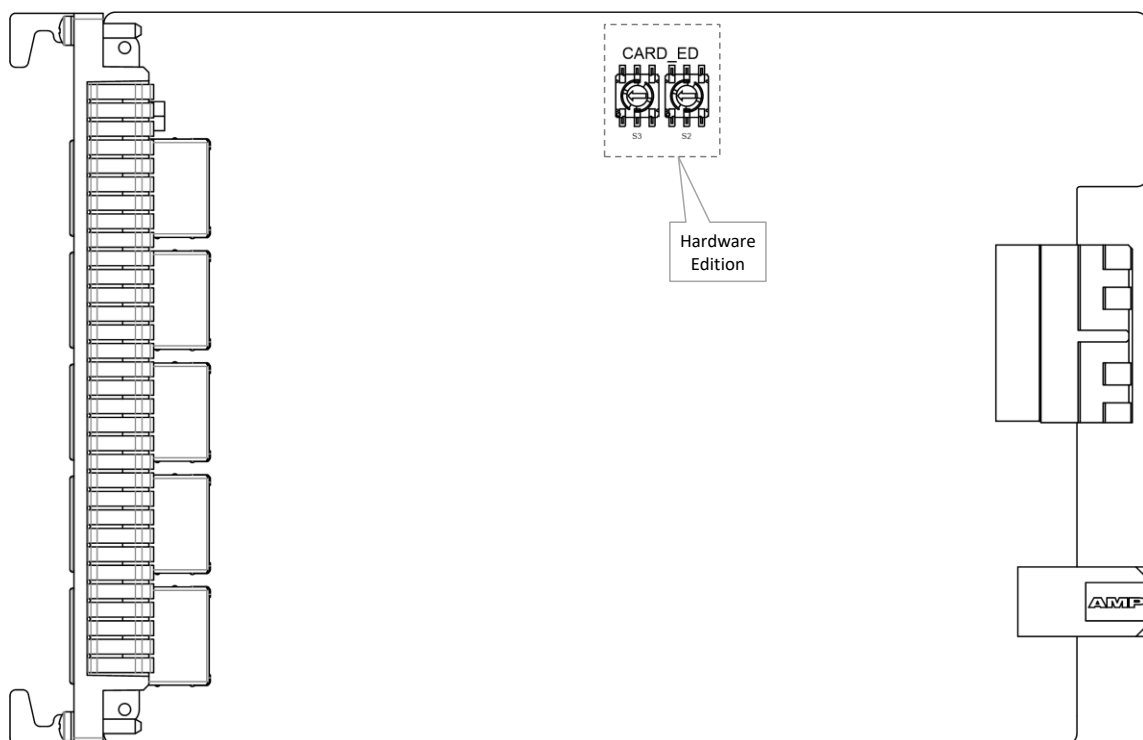

Figure 14 PTN-7-SERIAL: Side View

2.3.1 Straps

No user relevant straps.

2.3.2 DIP Switches

a. Hardware Edition

The Hardware Edition (labeled as CARD_ED) (see Figure 15) is set in decimal code using rotary switches S2 to S3 (=most significant). It can be read out as well via HiProvision. This edition has been factory set and **MUST NOT BE CHANGED!**

Example: Setting S3='0' and S2='5' indicates Hardware Edition '5' (dec).

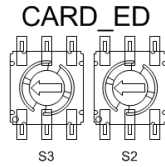

Figure 15 Hardware Edition

3. TDM FRAMES/PACKET FOR CES

3.1 General

In a CES service, the amount of TDM Frames per Ethernet packet is an important setting because it influences the amount of consumed bandwidth and delay through the network. The more TDM Frames/Package, the less bandwidth is used but the bigger the total delay through the network.

In HiProvision, it can be configured how many TDM Frames/Package can be encoded.

- ▶ Default TDM Frames/Package = 4 ;
- ▶ For CESoPSN: Minimum TDM Frames/Package: 1 or 2 depending on the configured settings:
 - ▶ Asynchronous:
 - ▶ bitrate < 19200 → value = 2;
 - ▶ bitrate >= 19200 → value = 1;
 - ▶ Synchronous:
 - ▶ bitrate = 64k → value = 2;
 - ▶ bitrate > 64k → value = 1;
- ▶ Maximum TDM Frames/Package, no Hitless Switching: 24;
- ▶ Maximum TDM Frames/Package, Hitless Switching: 10;

3.2 Bandwidth

If only one TDM frame per packet is encoded, it generates a lot of header information on the network resulting in a lot of consumed bandwidth. Encoding more frames into one packet will decrease the amount of header information and as a result the consumed bandwidth as well. As of 8 frames per packet and higher, the bandwidth consumption stabilizes towards the minimum bandwidth consumption. See the graph below.

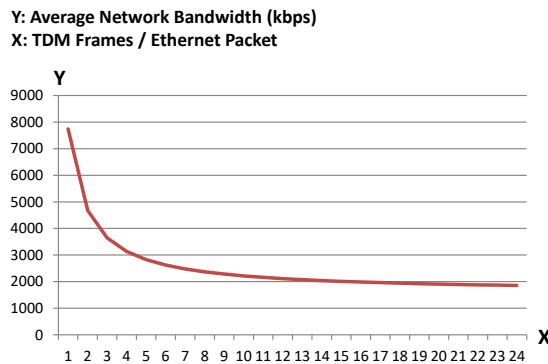

Figure 16 CESoPSN Bandwidth

3.3 Delay

3.3.1 General

The total delay between two end points over the Dragon PTN network depends on:

- ▶ **P** (=Packetization Delay): Delay to encode Serial input into MPLS-TP packets;
- ▶ **Path Delay**: Delay from source to destination over the MPLS-TP network path; can be measured by HiProvision via OAM delay measurement for the specific service; Path Delay = Delay external network (if any) + $5\mu\text{s}/\text{km}$ + $10\mu\text{s}/\text{node}$;
- ▶ **DP** (=Depacketization Delay): Delay to decode MPLS-TP packets into Serial output;
- ▶ **DPh**: Extra Depacketizing Delay due to hitless switching;
- ▶ **Total Delay** = Total Network delay between two Serial applications;
- ▶ **Total Delay** = (Packetization + Path + Depacketization + Hitless Switching) Delay;

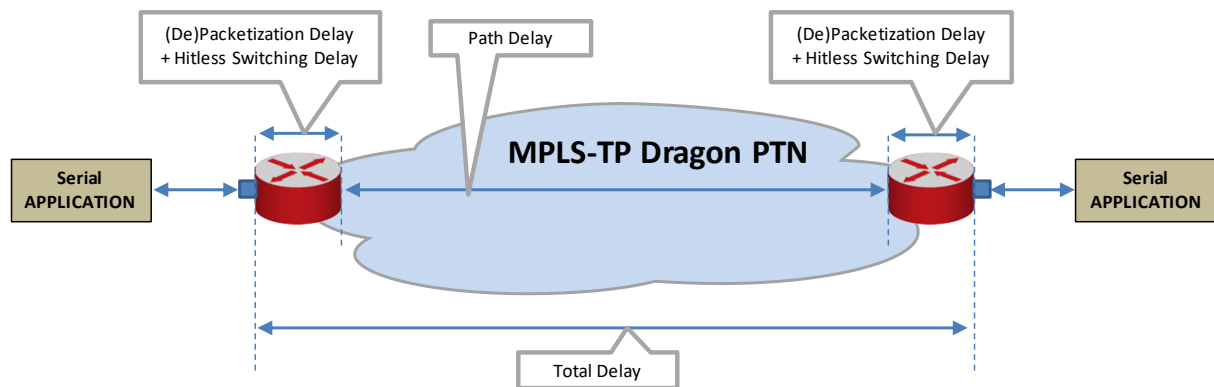

Figure 17 Delays

3.3.2 Delay Parameters

These delays in §3.3.1 depend on the selected service in HiProvision and its configured delay parameters. HiProvision offers the delay parameters listed below to tune the delay.

CAUTION: If you are not familiar with these parameters, keep the default values.

- ▶ **TDM Frames per Packet**: The lower the value, the lower the delay.
- ▶ **Jitter Buffer Size (μs)**: advice: Set this value to 'Packetizing Delay + expected peak-to-peak jitter (μs)'; The default peak-to-peak jitter could be $250\mu\text{s}$; The expected peak-to-peak jitter (μs) must be measured in the network. If the packetizing delay 'P' $< 2000\mu\text{s}$, set the buffer size to at least $2000\mu\text{s}$. If the packetizing delay 'P' $> 2000\mu\text{s}$ (e.g. $2500\mu\text{s}$), set the buffer size to at least e.g. $2500\mu\text{s}$.

CAUTION: By default, the jitter buffer will reset once for optimal processing 15 seconds after a change in the service occurs. This reset will cause a minimal loss of data. See 'jitter buffer' in the 'Dragon PTN and HiProvision Operation' Manual (=Ref. [1]) for more information.

- ▶ **Maximum Network Path Delay Difference (μs)** (only for Hitless Switching): advice: Set this value to '(Two Paths nodes difference)*10 + expected peak-to-peak jitter (μs)'. If path1 has 17 nodes and path2 has 8 nodes, this is a difference of 9 nodes. You could set $\text{MaxNetwPathDelayDiff} = 9*10 + 250 = 340\mu\text{s}$;

3.3.3 Estimated Delay Calculation and Formulas

Table 10 shows formulas to calculate an estimated delay. Once you have the desired estimated delay, fill out the parameter values in HiProvision, which shows the calculated 'P+DP+DPh'.

Table 10 Estimated Delay Formulas

Delay	No Hitless Switching	Hitless Switching
P	TDMFramesPerPacket * 125	
Path Delay	measured by HiProvision	
DP	(JitterBufferSize - P) / 2	
DPh	0	2P + MaxNetwPathDelayDiff + 1087
Total	P + Path Delay + DP + DPh	

3.3.4 Estimated Delay Examples

Fill out some example values below in the formulas to find the estimated total delay:

- ▶ TDMFramesPerPacket = 10
- ▶ Path Delay (measured by HiProvision) = 500 μs
- ▶ JitterBufferSize = 4000 μs
- ▶ MaxNetwPathDelayDiff = 340 μs

Table 11 Estimated Delay (μs) Examples

Delay	No Hitless Switching	Hitless Switching
P	<u>10</u> * 125 = 1250	
Path Delay	<u>500</u>	
DP	<u>(4000 - 1250) / 2 = 1375</u>	
DPh	0	2*1250 + <u>340</u> + 1087 = 3927
Total	1250 + 500 + 1375 + 0 = 3125 μs	1250 + 500 + 1375 + 3927 = 7052 μs

3.3.5 Differential Delay

Differential Delay is the difference in Path Delays between two end-points, measured in two opposite directions over the same path.

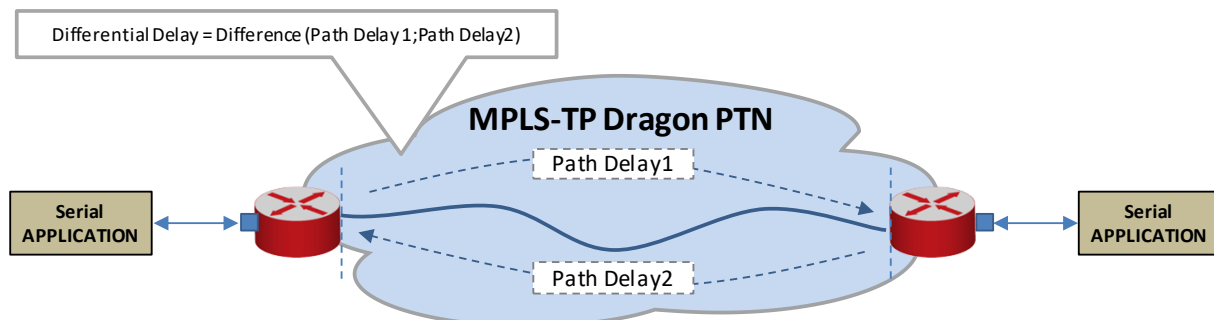

Figure 18 Differential Delay

When Differential Delay is very important for your application, we strongly advise to:

- ▶ Not use Hitless Switching with Single Path (§2.2.11), all the other modes are OK;
- ▶ Use SAToP (§2.2.8) when the differential delay must be as low as possible:
 - ▶ Maximum differential delay SAToP: 157 µs;
 - ▶ Maximum differential delay CESoPSN: 1125 µs;

3.4 Tuning CES = Tuning TDM Frames/Packet

Tuning the CES is mainly done by tuning the TDM Frames/Packet parameter. Tuning this parameter is a trade-off between bandwidth and delay. The more bandwidth is consumed the less the resulting network delay and vice versa. This tuning is application dependent. Check out whether bandwidth or delay is critical for an application or network. Based on these findings, bandwidth and delay parameters can be tuned.

Some examples according the information in §3.2 and §3.3:

- ▶ if bandwidth is not a problem, and a small delay is wanted → 1-3 TDM frames/packet;
- ▶ if less bandwidth is required and delay is not important → at least 4 TDM frames/packet;
- ▶ if less bandwidth and a small delay are wanted → 5 .. 10 TDM frames/packet.

4. MODULE SPECIFICATIONS

4.1 General Specifications

For general specifications like temperature, humidity, EMI ... see Ref.[5] in Table 1.

4.2 Other Specifications

Table 12 Other Specifications

Description	Value
Weight	0.24kg / 0.5 lb
MTBF	86 years at 25°C/77°F
Power Consumption	6.5W (measured at 25°C/77°F, with data transport)
Module Size	width: 20.32 mm / 0.8 inches height: 126 mm / 4.96 inches depth: 195 mm / 7.68 inches

4.3 Ordering Information

- ▶ PTN-7-SERIAL: 942 236-014.

5. ABBREVIATIONS

BERT	Bit Error Ratio Tester
CE	Conformité Européenne
CESoPSN	Circuit Emulation Service over Packet Switched Network

CSM	Central Switching Module
CTS	Clear To Send
DCD	Data Carrier Detect
DCE	Data Communication Equipment
DP	Depacketization Delay
DPh	Depacketization Delay due to Hitless Switching
DSR	Data Set Ready
DTE	Data Terminal Equipment
DTR	Data Terminal Ready
EMI	Electromagnetic Interference
ERR	Error
FLT	Fault
GND	Ground
IEEE	Institute of Electrical and Electronics Engineers
LAN	Local Area Network
LVD	Low Voltage Directive
LT	Line Termination
MTBF	Mean Time Between Failures
NT	Network Termination
OAM	Operations, Administration and Maintenance
PF	Power Failure
PI	Power Input
PME	Physical Medium Entities
PRC	Primary Reference Clock
PTN	Packet Transport Network
RTS	Request To Send
RTU	Remote Terminal Unit
RxC	Receive Clock
RxD	Receive Data
SCADA	Supervisory Control and Data Acquisition
SCTE	Serial Clock Transmit External
TTC	Terminal Timing Clock
TxD	Transmit Data
WAN	Wide Area Network

