



# HIRSCHMANN

A **BELDEN** BRAND

## Manual

# Universal RS 485 Fiberoptic Repeater OZD 485 G12(-1300) PRO

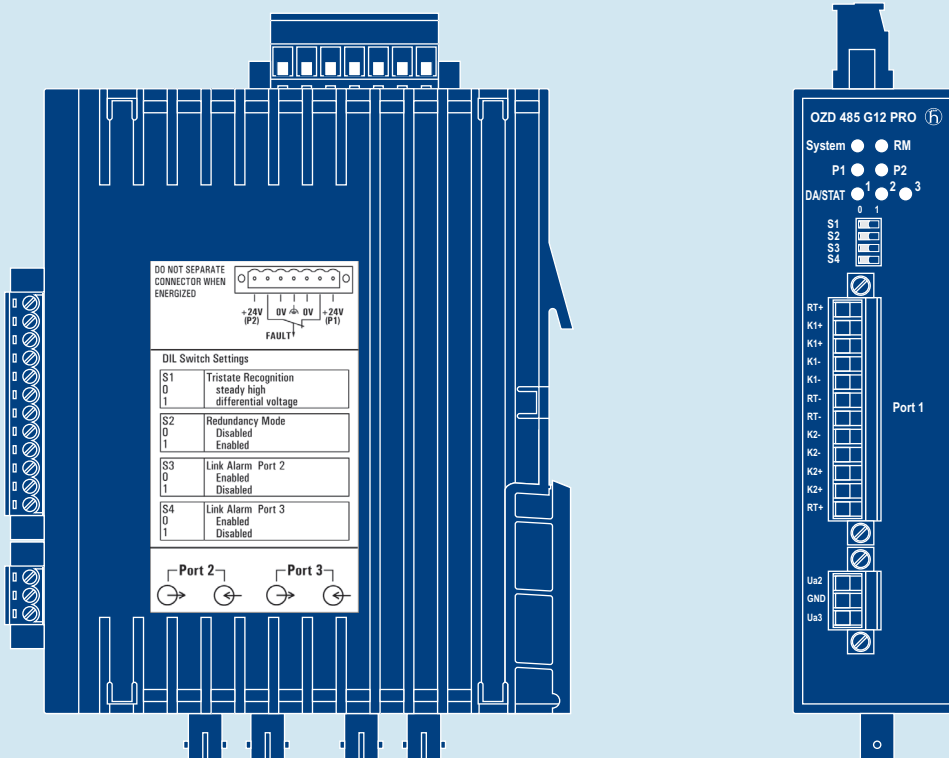

## Order Numbers

OZD 485 G12 PRO	943 894-321
OZD 485 G12-1300 PRO	943 895-321
Manual Universal RS 485 Fiberoptic Repeater OZD 485 G12(-1300) PRO	039 555-001

The performance features described here are binding only if they have been expressly agreed when the contract was made. We have checked the content of this document for consistency with the hardware and software it describes. However, inconsistencies cannot be ruled out, and thus we cannot guarantee absolute consistency. Nevertheless, the information in the document is checked regularly. Necessary corrections are contained in the following printings. We are grateful for any suggested improvements.

Technical modifications reserved.

This document may not be passed on, copied, nor may its contents be used or distributed, unless expressly permitted. Violators will be held liable for compensation. All rights are reserved, particularly if a patent is granted or the design is registered.

© Hirschmann Automation and Control GmbH

All Rights Reserved

## Note

We wish to point out that the content of this manual is not part of a previous or existing agreement, consent, or legal relationship, or shall not amend same. All the liabilities of Hirschmann result from the respective sales contract, which also contains the complete and solely valid guarantee regulations. These contractual guarantee specifications are neither enhanced nor restricted by the information in this manual.

We also wish to point out that for reasons of comprehensibility, not every conceivable problem relating to the use of this device can be described in this manual. Should you require further information, or should particular problems occur which are not dealt with in sufficient detail in this manual, you can request the required information from your local Hirschmann dealer or directly from Hirschmann (for address, see section "Note on CE Marking").

## Notes on safety

This manual contains instructions to be observed for ensuring your personal safety and for preventing damage. The warnings appear next to a warning triangle with a different heading depending on the degree of danger posed:



### **Danger!**

Means that death, serious physical injury or considerable damage to equipment **will** occur if the required precautionary measures are not taken.



### **Warning!**

Means that death, serious physical injury or considerable damage to equipment **can** occur if the required precautionary measures are not taken.



### **Caution!**

Means that minor physical injury or damage to equipment can occur if the required precautionary measures are not taken.

### **Note:**

Contains important information on the product, on how to manage the product, or on the respective section of the documentation to which your particular attention is being drawn.

## Qualification requirements for personnel

### **Note:**

Qualified personnel as understood in this manual and the warning signs, are persons who are familiar with the setup, assembly, startup, and operation of this product and are appropriately qualified for their job. This includes, for example, those persons who have been:

- trained or instructed or authorized to switch on and off, to ground and to label power circuits and devices or systems in accordance with current safety engineering standards;
- trained or instructed in the care and use of appropriate safety equipment in accordance with the current standards of safety engineering;
- trained in providing first aid.

## General safety instructions

- ▶ This device is operated by electricity. You must follow precisely the prescribed safety requirements in the operating manual that relate to the voltage connections!
- ▶ Make sure that the electrical installation meets local or national safety regulations.



### **Warning!**

Non-observance of these safety instructions can cause material damage and/or serious injuries. Only appropriately qualified personnel should work on this device or in its vicinity. This personnel must be thoroughly familiar with all the warnings and maintenance procedures in accordance with this operating manual.

The proper and safe operation of this device depends on proper handling during transport, proper storage and assembly, and conscientious operation and maintenance procedures. Never start operation with damaged components.



### **Warning!**

Any work that may be required on the electrical installation may only be carried out by personnel trained for this purpose.



### **Warning!**

LASER CLASS 1 in compliance with IEC 60825-1 (2014).

## Correct operation

Please note the following:



### **Warning!**

The device may only be used for those purposes specified in the catalog and in the technical description, and only in combination with external devices and components approved by Hirschmann. The proper and safe operation of this product depends on proper handling during transport, proper storage and assembly, and conscientious operation and maintenance procedures.

## Safety instructions for supply voltage

- ▶ Only switch on the device when the housing is closed.



### Warning!

The devices may only be connected to the supply voltage shown on the type plate. The devices are designed for operation with safety extra-low voltage. Accordingly, only PELV circuits or SELV circuits with voltage restrictions in line with IEC/EN 60950 may be connected to the supply voltage connections and the signal contact.

- ▶ If you are operating the module with an external voltage: Only supply the system with a low safety voltage in compliance with IEC/EN 60950.

Relevant for North America:

- ▶ The device may only be connected to a supply voltage of class 2 that fulfils the requirements of the National Electrical Code, Table 11(b). If the voltage is being supplied redundantly (two different voltage sources), the combined supply voltages must fulfil the requirements of the National Electrical Code, Table 11(b).
- ▶ Use 90 or 90°C copper(CU) wire only.

## Safety instructions for environment



### Warning!

The device may only be operated in the specified ambient temperature and relative air humidity (non-condensing).

- ▶ Select the installation site so that the climatic threshold values specified in the technical data are adhered to.
- ▶ Only to be used in an environment with contamination level 2 (IEC 60664-1).

## Safety instructions for housing



### Warning!

Only technicians authorized by Hirschmann are permitted to open the housing.

## Underlying norms and standards

The devices fulfill the following norms and standards:

- EN 61000-6-2:2001 Generic standards – Immunity for industrial environments
- EN 55022:1998 + A1 2000+A2:2003 – Information technology equipment – Radio disturbance characteristics
- EN 61131-2: Programmable controllers
- EN 60825-1 Safety of laser products
- FCC 47 CFR Part 15:2004 – Code of Federal Regulations

## Note on the CE marking



The devices comply with the regulations of the following European directives:

89/336/EEC

Council Directive on the harmonization of the legal regulations of member states on electromagnetic compatibility (amended by Directives 91/263/EEC, 92/31/EEC and 93/68/EEC).

The precondition for compliance with EMC limit values is strict adherence to the installation guidelines specified in this description and operating instructions.

The EU declaration of conformity is kept available for the responsible authorities in accordance with the above-mentioned EU directives at:

Hirschmann Automation and Control GmbH

Stuttgarter Strasse 45 - 51

72654 Neckartenzlingen

Germany

Telephone +49 (0) 1805 14-1538

Email HAC.Support@Belden.com

The product can be used in the residential sphere (residential sphere, business and trade sphere and small companies) and in the industrial sphere.

- Interference immunity:  
EN 61000-6-2:2001
- Interference emissions:  
EN 55022:1998+A1:2000+A2:2003 Class A



### Warning!

This is a Class A device. This equipment may cause radio interference if used in a residential area; in this case it is the operator's responsibility to take appropriate measures.

## FCC RULES

This device complies with part 15 of the FCC Rules. Operation is subject to the following two conditions:

- (1) This device may not cause harmful interference, and
- (2) This device must accept any interference received, including interference that may cause undesired operation.

**Note:** This equipment has been tested and found to comply with the limits for a Class A digital device, pursuant to part 15 of the FCC Rules. These limits are designed to provide reasonable protection against harmful interference when the equipment is operated in a commercial environment. This equipment generates, uses, and can radiate radio frequency energy and, if not installed and used in accordance with the instruction manual, may cause harmful interference to radio communications. Operation of this equipment in a residential area is likely to cause harmful interference in which case the user will be required to correct the interference at his own expense.

## Recycling note



After usage, this product must be disposed of properly as electronic waste in accordance with the current disposal regulations of your county/state/country.

## C-Tick

### Australia/New Zealand



This product meets the requirements of the AS/NZS 3548 standard.

N1337

## Certifications

### cUL508

Please note the important information in: Chapter 5.4, "Use in North America", page 23.

### ISA12.12.01

Hazardous Locations Class1 Div 2 Groups  
A, B, C und D

Please note the important information in: Chapter 5.4  
"Use in North America", page 23.

### ATEX Directive 94/9/EC Zone 2 3G

Please note the important information in: Chapter 5.2  
"Use in Ex-zone 2 according to ATEX 94/9/EC", page 21.

### Note:

Only the certifications indicated on the label attached to each device are applicable.



# Contents

<b>1 Introduction</b>	7
<b>2 Half/full duplex operation</b>	9
2.1 Half duplex operation	9
2.2 Full duplex operation	10
<b>3 Tristate recognition</b>	11
3.1 Tristate recognition through permanent high	11
3.2 Tristate recognition through differential voltage	12
<b>4 Network topologies</b>	13
4.1 Line topology without redundancy	13
4.2 Redundant ring	14
4.3 Star distributor	15
4.4 Network range	16
4.5 Cascadability and data rate	16
<b>5 Installation</b>	19
5.1 Installation guidelines	19
5.2 Use in Ex-zone 2 according to ATEX RL 94/9EG	21
5.3 Control Drawing	23
5.4 Use in North America	25
5.5 Installing procedure	25
5.6 Installing repeater	26
5.7 Installing terminating resistor and pull-up/pull-down resistors	27
5.8 Setting DIL switches	28
5.9 Connecting the optic bus cables	29
5.10 Connecting the electric bus cables	29
5.11 Connecting the function ground	30
5.12 Connecting the signal contact lines (optional)	30
5.13 Connecting the analog voltage outputs (optional)	31
5.14 Connecting the operating voltage supply	32
5.15 Checking the LED indicators	32

<b>6 Bus configurations</b> .....	33
6.1 BITBUS .....	33
6.2 DIN measurement bus .....	34
6.3 InterBus-S .....	35
6.4 Modbus RTU/Modbus ASCII .....	35
6.4.1 Specification of the Modbus variants .....	36
6.4.2 Without Line Polarization .....	37
6.4.3 With Line Polarization .....	38
6.5 Configuration of other bus systems .....	39
<b>7 Help with problems</b> .....	41
7.1 LED displays .....	41
7.2 Troubleshooting .....	42
7.3 Problem reporting .....	43
7.4 Contact address .....	44
<b>8 Technical data</b> .....	45



# 1 Introduction

The RS 485 Fiberoptic Repeater OZD 485 G12(-1300) PRO is intended for use in optical RS 485 fieldbus networks such as Modbus RTU, Modbus ASCII, BITBUS and company-specific busses. It enables you to convert electrical RS 485 signals to optical ones, and the reverse. With the OZD 485 G12(-1300) PRO Repeaters, you can construct universal half (2-wire) or full (4-wire) duplex transmission systems with RS 485 interfaces.

You can integrate the Repeaters into existing electrical RS 485 fieldbus networks. You can also build up a complete optical RS 485 fieldbus network in line, ring or star topologies with OZD 485 G12(-1300) PRO Repeaters.

The housing consists of two plastic sections and a front panel made of metal. It can be mounted on a DIN rail.

## Ports

The Repeater has three independent ports, which in turn consist of a transmitter and a receiver component. Port 1 is a 12-pin screw terminal block, and ports 2 and 3 are optical BFOC/2.5 (ST<sup>®</sup>) sockets.

## Power supply

The power supply is +18 V to +24 V (for non-hazardous locations only: +18 V to +32 V) direct current. To improve the operating safety, a redundant operating power supply consisting of two separate sources can be used. For this purpose, you must connect the two operating voltages to two different terminals of the 7-pin screw terminal block.

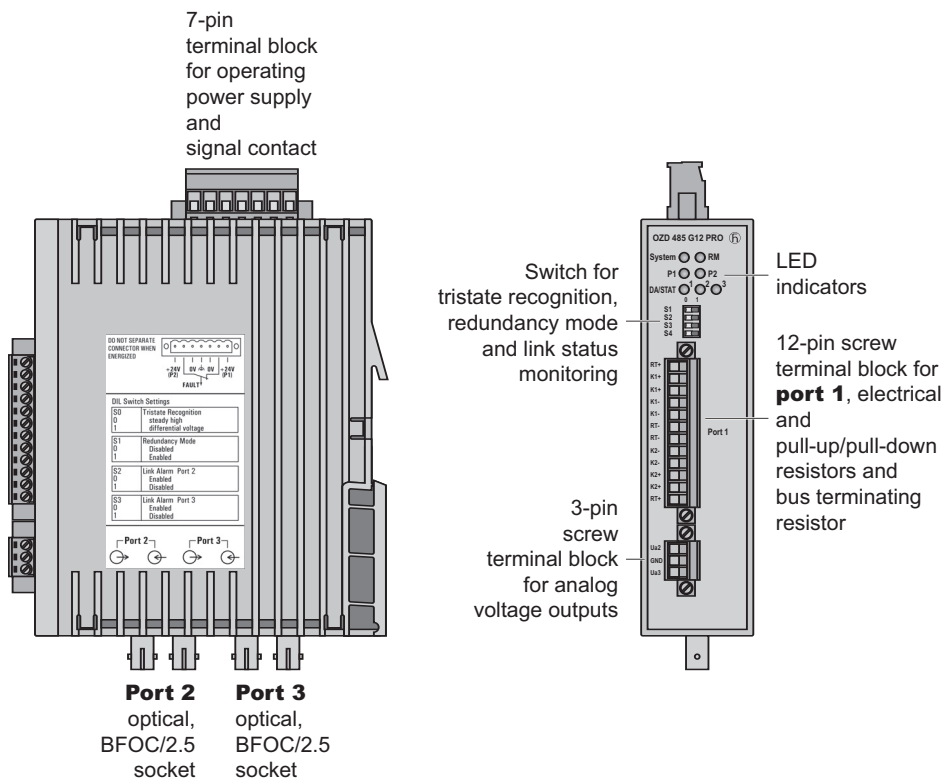

Fig. 1: Fiberoptic Repeater OZD 485 G12(-1300) PRO with location of individual ports, terminal blocks and LED displays

Both connections are uncoupled by means of diodes to prevent reverse voltage supply or destruction through incorrect pole connection.

There is no load distribution between the sources. With redundant supply, the power supply unit with the higher output voltage must supply the repeater alone.

### Signal contact

A signal contact (relay with unconnected contacts) is used to signal various disruptions in the repeaters. The signal contact is also connected to the 7-pin screw-type terminal block.

### LEDs

Seven one- and two-colored light-emitting diodes signal the current operating status and any possible operating errors.

### Configuration

You can easily set the configuration to meet your specific requirements by means of DIL code switches, which can easily be operated from outside.

The following settings are possible:

- Tristate recognition
- Redundancy mode
- Signaling a lower power input at optical port 2
- Signaling a lower power input at optical port 3

### Glass fiber technology

The use of glass fiber transmission technology enables a very large transmission range and ensures optimal protection from EMC effects on the transmission path and – due to the potential separation – on the Repeater itself.

### Transmission speed

The RS 485 Fiberoptic Repeater OZD 485 G12(-1300) PRO supports all data rates from 0 to 1.5 MBit/s NRZ.

### Network range

The permissible network range for the line, ring or star topology depends on the bus system and terminal devices used. See chapter 4.4, page 16.

### Redundancy

The redundant ring enables a very high level of transmission reliability. The redundant operating power supply can further improve the operating reliability.

### Device models

The RS 485 Fiberoptic Repeaters OZD 485 G12 ... PRO are available as OZD 485 G12 PRO for multi-mode fibers (50/125  $\mu\text{m}$  and 62.5/125  $\mu\text{m}$ ) and as OZD 485 G12-1300 PRO for single-mode fibers (10/125  $\mu\text{m}$ ) and multi-mode fibers (50/125  $\mu\text{m}$  and 62.5/125  $\mu\text{m}$ ).

### Compatibility with other RS 485 Fiberoptic Repeaters

The **OZD 485 G12 PRO** may be operated via the optical ports

- together with the RS 485 Fiberoptic Repeater OZD 485 G12, or
- together with the RS 485 Fiberoptic Repeater OZD 485 G12 BAS, if only those properties that are also supported by the OZD 485 G12 BAS are used in the entire network.

The **OZD 485 G12-1300 PRO** may be operated via the optical ports

- together with the RS 485 Fiberoptic Repeater OZD 485 G12-1300.

## 2 Half/full duplex operation

### 2.1 Half-duplex operation

The two data channels of the electrical port, K1 and K2, can transmit data simultaneously and independently of one another in half-duplex mode <sup>1)</sup>. Each data channel replaces a 2-wire cable.

In half-duplex mode, the arbitration procedure used by the connected devices must ensure that at any given time, only one device can access the bus, like in master/slave operation. Access procedures where there is a risk of collisions, such as CAN, are not permissible.

In half-duplex mode, consecutive data telegrams must be separated by a minimal time gap so that the end of a

data telegram can be definitively recognized and thus the data direction can be switched in the OZD 485 G12 (-1300) PRO. For the tristate recognition through permanent high, this gap is 3.5  $\mu$ s, while for the tristate recognition through differential voltage, it is 1  $\mu$ s. You can cascade a number of OZD 485 G12(-1300) PRO via the optical interfaces <sup>1)</sup>. Devices or bus segments may be connected to the electrical interfaces of all the cascaded OZD 485.

1) When you use both data channels K1 and K2 at the same time and while cascading the repeaters the increased jitter causes a reduction in the maximum permissible transmission rate and/or the cascadability. See chapter 4.5, page 16.

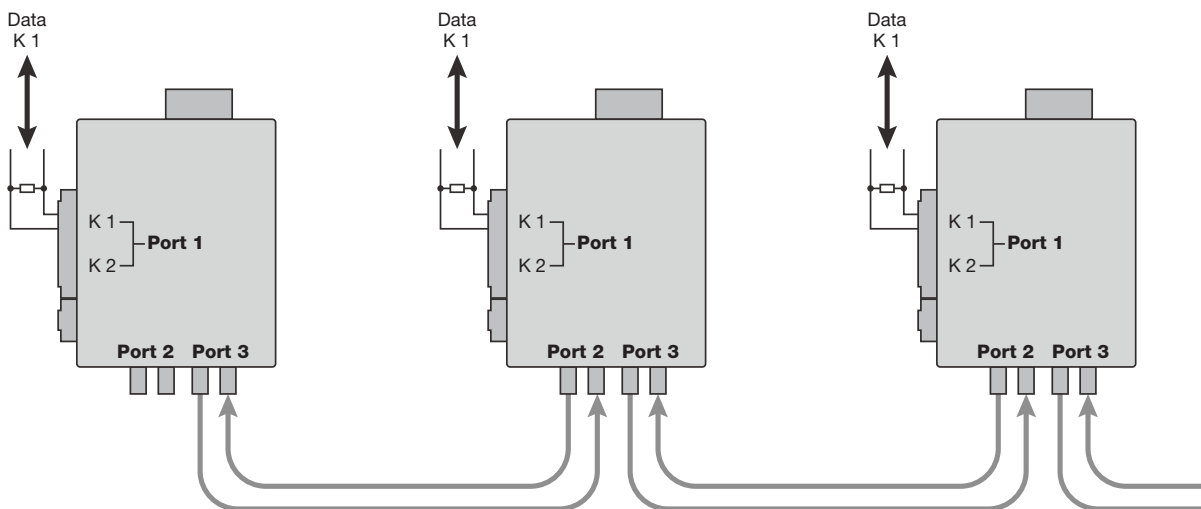

Fig. 2: Half-duplex mode – data channel K1 is used for data transmission, and data channel K2 is not used

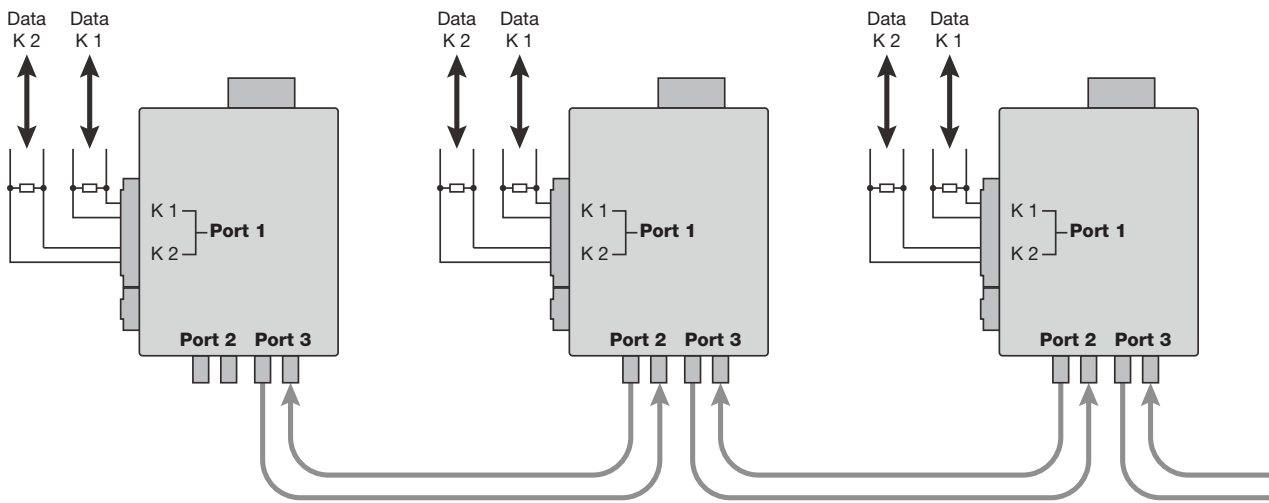

Fig. 3: Half-duplex mode – data channel K1 and data channel K2 are used for data transmission.

## 2.2 Full-duplex operation

In full-duplex mode, you can set up a bi-directional connection between two devices. The data channels K1 and K2 are each used for data transmission in one direction. You can cascade more than two OZD 485 G12(-1300) PRO via the optical interfaces.

The arbitration procedure used by the connected devices must ensure that at any given time only one single bus participant is sending on channel 1 and only one is sending on channel 2. Access methods that can cause collisions on channel 1 or channel 2 are not permissible.

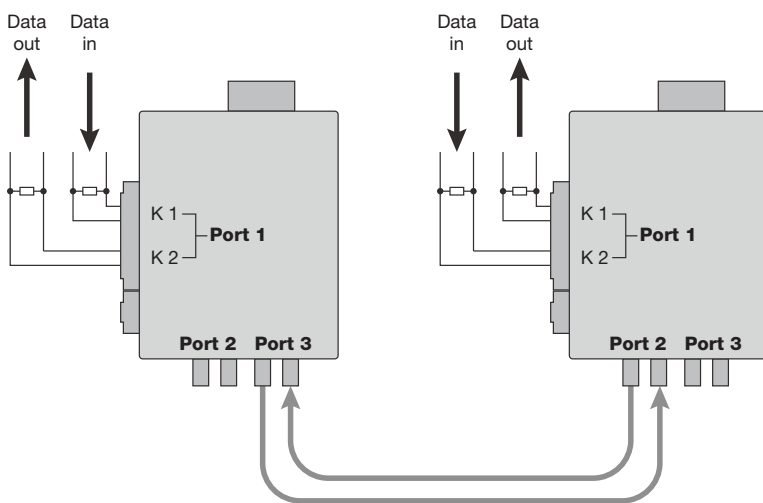

Fig. 4: Full-duplex mode – the data channels K1 and K2 are each used for data transmission in one direction.

### 3 Tristate recognition

The type of tristate recognition depends on the termination of the bus system used. See also chapter 5.7, page 25.

#### 3.1 Tristate recognition through permanent high

One 2-wire lead, terminated by a characteristic impedance and additional pull-up/pull-down resistors, is replaced (e.g. Modbus RTU/ASCII).

During the idle phase, a logical high level (positive voltage between terminals K1+ and K1-) is available. As soon as a constant high level is available for 2.5  $\mu$ s,

the repeaters identify this as tristate and switch their transmitters to the idle state (transmitter set to high-resistance).

A downward slope is identified as the start bit. Transmission is made in the appropriate direction. The opposite direction is disabled.

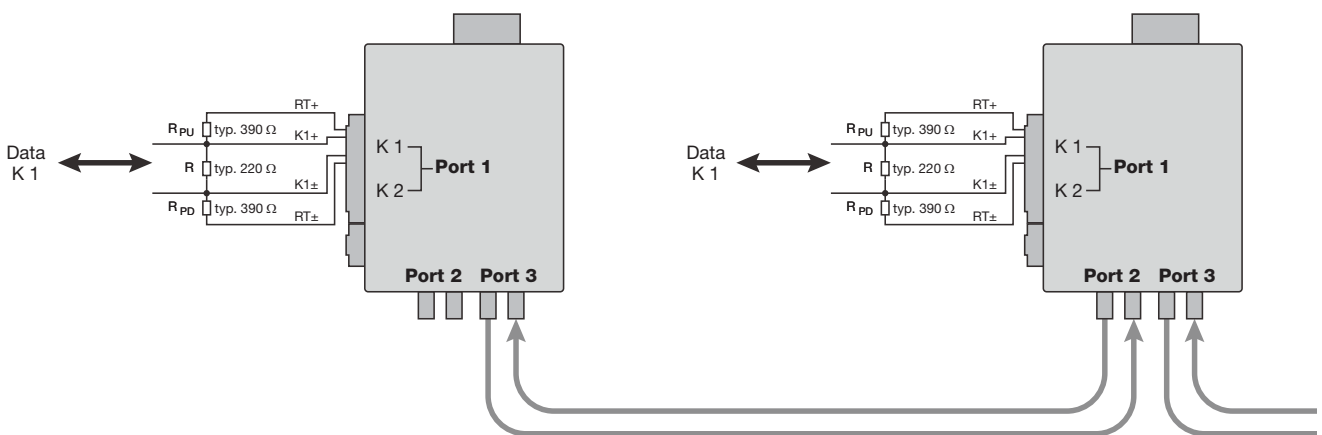

Fig. 5: Tristate recognition through permanent high

**3.2 Tristate recognition through differential voltage**

A 2-wire lead only terminated by a characteristic impedance is replaced.

During the idle phase, the differential voltage falls below a certain value. The repeater recognizes this as tristate.

If a switching limit is exceeded, the transmission is made in the appropriate direction. The opposite direction is disabled.

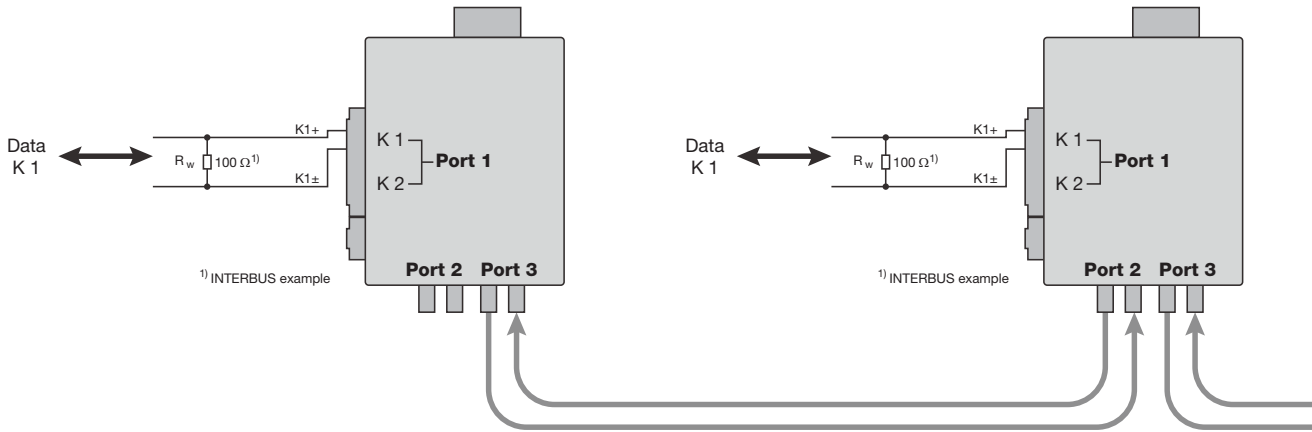

Fig. 6: Tristate recognition through differential voltage (INTERBUS example).

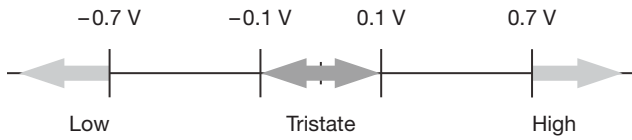

Fig. 7: Switching limit within which the OZD 485 G12(-1300) PRO repeaters recognize tristate (indicated in dark gray), and the related minimum/maximum voltage values for the logical conditions "high" and "low" (indicated in light gray).

## 4 Network topologies

### 4.1 Line topology without redundancy

This network topology can be used for an optical connection of end devices or bus segments.

For the repeaters at the end of the line, the DIL switch S3 or S4 of the related, non-occupied optical port must be in position "1", which means that too low incoming power at port 2 or port 3 is not signalled at the signal contact.

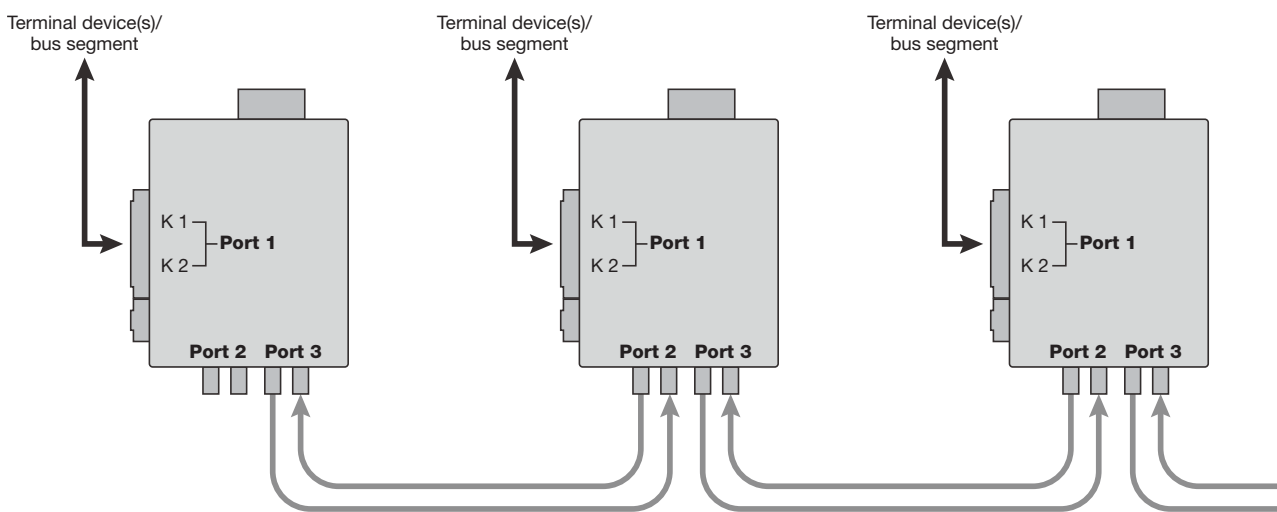

Fig. 8: Line topology without redundancy

## 4.2 Redundant ring

In a redundant ring, the redundancy mode must be activated in exactly one repeater (switch S2, see chapter 5.8, page 26). In this case, the optical port 2 of this repeater is the redundant port (indicated in dark gray in the illustration below). If there are no errors it transmits no data, but it monitors the optical input power of the data received. If an error occurs within the ring due to the failure of an optical lead or a repeater, then the redundant port becomes active after a maximum of 1.4 ms and begins transmitting the data.

After the error has been resolved, the redundant port becomes inactive again. The maximum interruption is 0.4 ms.

Within a redundant ring there may only be optical transmission links.

The redundant ring can be used in the half-duplex and in the full-duplex mode.

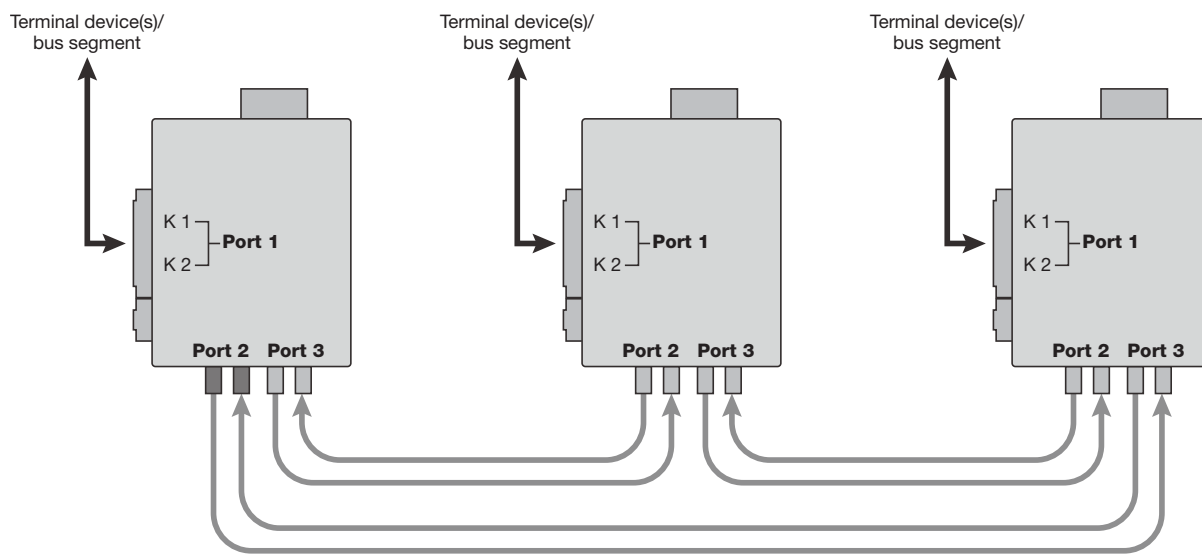

Fig. 9: Redundant ring



### 4.3 Star distributor

The star distributor is made by coupling two or more OZD 485 G12(-1300) PRO via the electrical interfaces. Lines or other star distributors can be connected to the optical interfaces of the coupled repeaters. The star distributor can be combined with the redundant ring. Within a redundant ring there may only be optical transmission links.

The termination at the start and end of the star point lead must have the same resistance values as the termination of the bus.

The star distributor can be used to create bridges between single-mode and multi-mode fiber links.

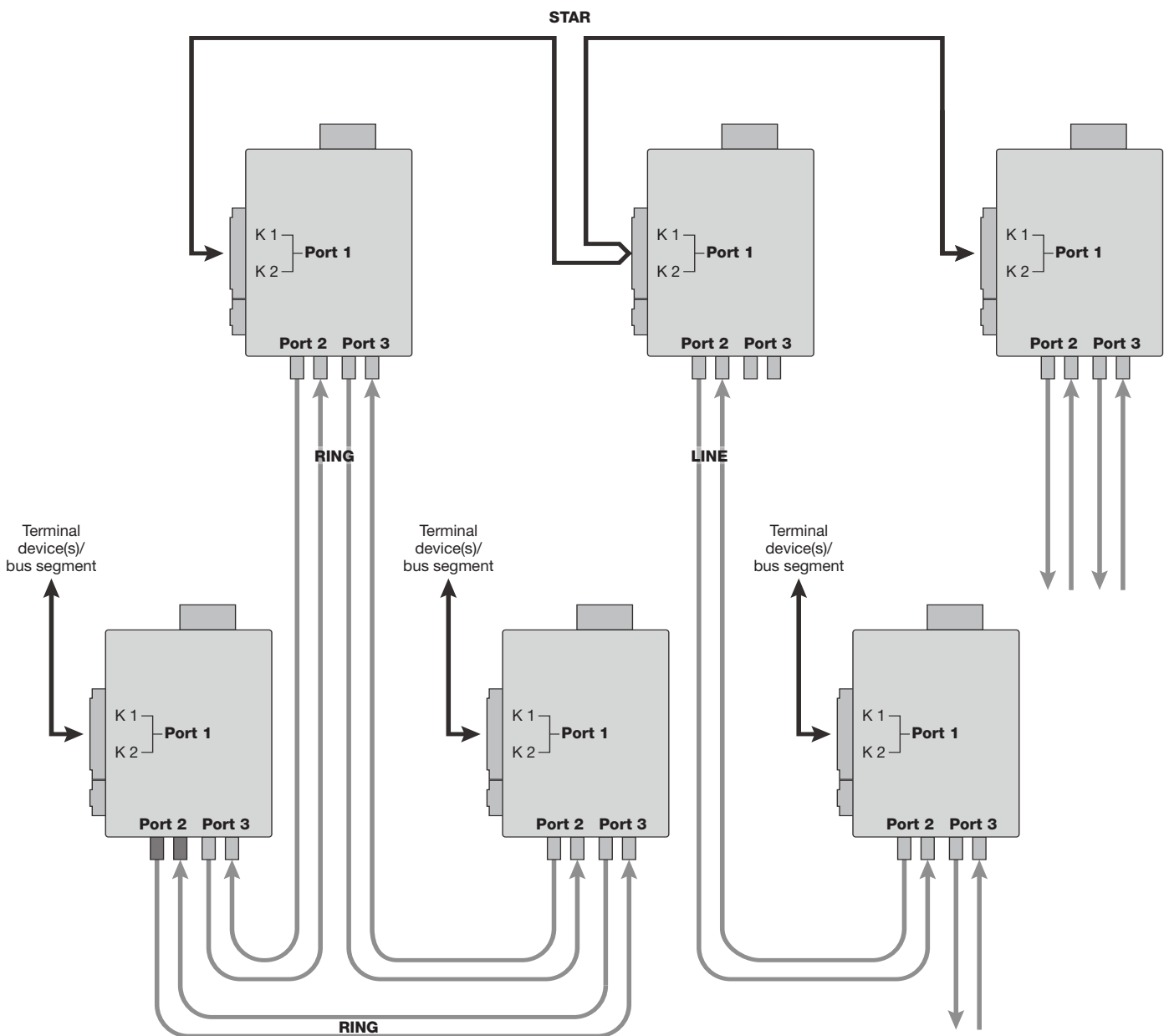

Fig. 10: Star distributor

## 4.4 Network range

The maximum network range depends on the permissible signal processing times of the bus system and terminal devices used.

The signal processing time for the planned network  $t_N$  is made up of the signal processing times from the electrical leads (approx. 5  $\mu\text{s}/\text{km}$ ) and the optical fibers (approx. 5  $\mu\text{s}/\text{km}$ ) and the signal processing times in the repeaters OZD 485 G12(-1300) PRO (max. 1.33  $\mu\text{s}/\text{repeater}$ ).

In the **line structure**,  $t_N$  is equal to the total processing time between the two ends of the line.

In the **star structure**,  $t_N$  is equal to the longest processing time in the network.

In the **redundant ring structure**,  $t_N$  is equal to the longest processing time in the network, whereby every possible ring interruption must be taken into account! The signal processing time only in the optical ring may be a maximum of 320  $\mu\text{s}$ .

## 4.5 Cascadability and data rate

The cascadability depends on how big the permissible bit duration distortion of the bus system used or the terminal devices is.

The increase in the bit duration distortion due to jitter in the optical transmission link depends on the following criteria:

- Number of OZD 485 G12(-1300) PRO in the transmission link
- One-channel or two-channel operation

### Determining the cascadability

To determine the maximum cascadability in a planned network, you must know the following:

- Maximum permissible bit duration distortion in the bus system or terminal devices used
- Transmission rate
- Only one channel (one-channel mode) or both channels (two-channel mode) in half-duplex mode

### Example of one-channel mode

The permissible bit duration distortion in the end devices is 20%, for example. If the transmission rate is 1 Mbit/s, then a bit that is nominally 1  $\mu\text{s}$  long may be lengthened or shortened by 200 ns.

The increase in jitter for each OZD 485 G12(-1300) PRO is 10 ns. The result of this is that in one-channel mode, there may be up to 20 OZD 485 G12(-1300) PRO in the transmission link (see fig. 11).

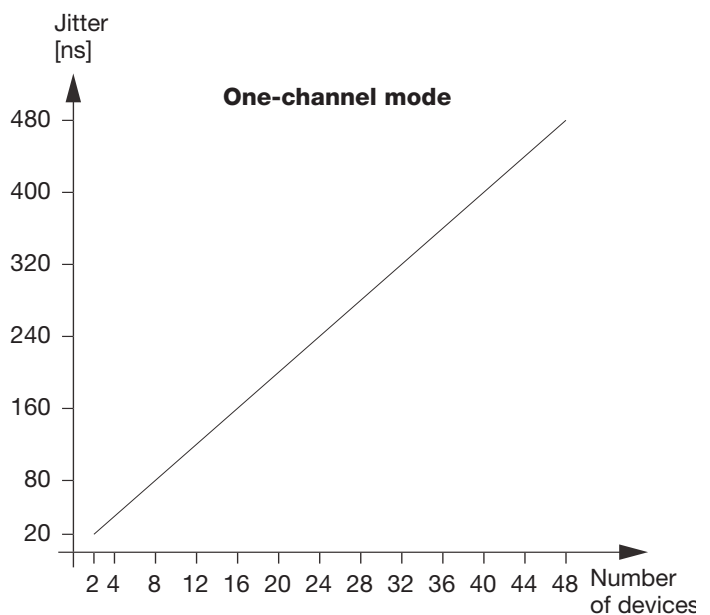

Fig. 11: Relationship between number of devices and jitter in one-channel mode

**Example of two-channel mode**

The permissible bit duration distortion in the end devices is 10%, for example. If the transmission rate is 100 kbit/s, then a bit that is nominally 10  $\mu$ s long may be lengthened or shortened by 1  $\mu$ s. Of this, 0.6  $\mu$ s is used by the two-channel mode.

The increase in jitter for each OZD 485 G12(-1300) PRO is 10 ns.

The result of this is that with the remaining 400 ns, there may be up to 40 OZD 485 G12(-1300) PRO in the transmission link in two-channel mode (see fig. 12).

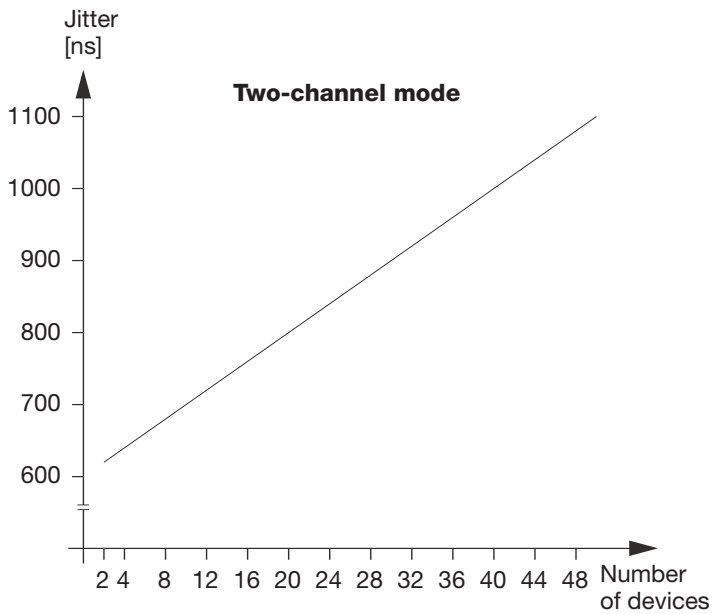

Fig. 12: Relationship between number of devices and jitter in two-channel mode



## 5 Installation

### 5.1 Installation guidelines

#### Electromagnetic compatibility (EMC)

Electromagnetic compatibility (EMC) covers all aspects regarding the effects of radiated and received electrical, magnetic and electromagnetic emissions.

In order to prevent interference in electrical systems, these effects must be reduced to a minimum.

The structural design and correct connection of bus lines as well as the interference suppression of switched inductances play a major role in limiting interference.

#### Interference suppression of switched inductances

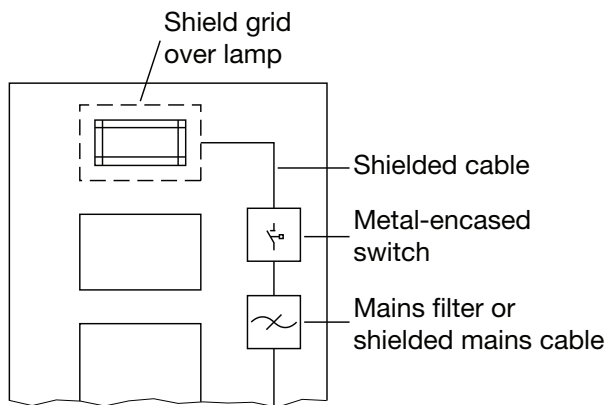

Fig. 13: Interference suppression of fluorescent lamps in cabinet

- ▶ Suppressing switched inductances with fuses  
Switching inductances, e.g. in relays and fans, generates interference voltages which are many times higher than the switched operating voltages. These interference voltages might affect electronic appliances. The interference voltages of inductances must be limited at their source of emission by means of fuses (by connecting diodes or RC elements). Only use interference suppressors which are intended for the relays and fans used.
- ▶ Cabinet lighting  
Use filament lamps (e.g. LINESTRA lamps) for the cabinet lighting. Do not use fluorescent lamps because they generate interference fields. If the use of fluorescent lamps cannot be avoided, the interference suppression measures shown in Fig. 13 must be implemented.

#### Arrangement of devices and cables

- ▶ Reducing interference by providing adequate space  
A simple yet effective way of reducing interference is to separate devices and cables causing interference from those affected by interference. Inductive and capacitive interference injection decreases by the square of the distance between the elements concerned. This means that doubling the distance reduces the interference by a factor of 4. If the arrangement of the various elements in a building or in the switch cabinet is taken into consideration at the planning stage, the cost of the necessary interference suppression measures is generally very low.
- ▶ Please note:  
Between an OZD 485 G12(-1300) PRO and a power switching element (e.g. contractor, relay, temperature regulator, switch, etc.) a minimum separation of 15 cm is to be maintained. This minimum is to be measured between the outer edges of the components and in all directions around an OZD 485 G12(-1300) PRO.

The power supply wires (+24 VDC and 0 V) for the OZD 485 G12(-1300) PRO must not be laid in the same cable duct as cables for load circuits. The wires (+24 VDC and 0 V) should be twisted together.

- ▶ Standard recommendations for the arrangement of devices and cables  
EN 50174-2 contains recommendations for arranging devices and cables which are aimed at reducing mutual interference to a minimum.
- ▶ Using bus line shields  
It is important to observe the following when shielding bus lines:
  - Only use fully shielded lines. The shields of these lines must be of sufficient thickness to satisfy the legal requirements for interference radiated and interference received.

- Always attach the shields at both ends of the bus lines. The legal requirements regarding interference radiated and interference received for your system will only be satisfied if shields are connected at both ends (CE symbol).
- Dismantle the shield of the bus cable completely and put it on an equipotential rail. This rail must in turn be connected with the function ground of the OZD 485 G12(-1300) PRO by means of a short cable.

#### Note:

If differences in potential occur between the grounding points, an inadmissably high compensating current could flow across the shielding connected at both ends. Never eliminate this problem by removing the shielding from the bus line!

The following solution is permissible:

Lay an additional equipotential bonding cable parallel to the bus line.

### Shield connections

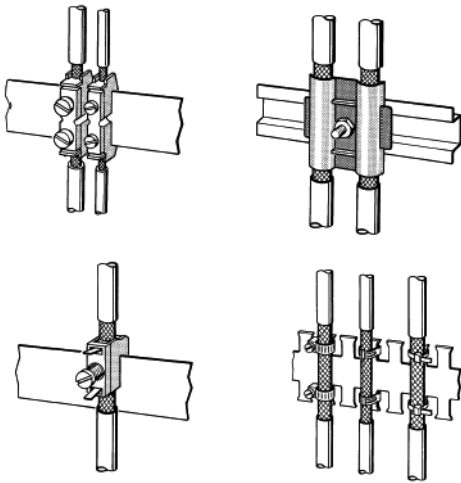

Fig. 14: Securing shielded lines using cable clamps and tube clips (schematic diagram)

Always observe the following points when installing bus line shielding:

- ▶ Secure the shield braid using metal cable clamps.
- ▶ The clamps must fully enclose the shield and make good contact (see Fig. 14).
- ▶ Only contact the lines via the copper braid shield.
- ▶ The shields of all cables which are routed into a cabinet from the outside must be clamped at the point of entry inside the cabinet and connected to the cabinet ground with a large contact surface area.
- ▶ When removing the cable jackets, it is important to ensure that the braid shield of the cables is not damaged. Tin-plated or galvanically stabilized surfaces are ideal for optimum contacting between grounding elements. With zinc-plated surfaces, suitable threaded connections must be provided for the required contacts. Painted surfaces at the contact points are unsuitable.
- ▶ Shield clamps/contact points should not be used as strain relief devices. Contact with the shield bus could otherwise deteriorate or break completely.

## 5.2 Use in Ex-zone 2 according to ATEX 94/9/EG

### Relevant information for use in Ex zone 2 according to ATEX 94/9/EG

**This product may be operated in EX zone 2 only if the product label is marked accordingly.  
The following information applies when operating this equipment in EX zone 2:**



II 3G

Ex nA ic IIC T4 Gc

DEMKO 07 ATEX 142156X

Temperature Code T4	Ta: -25 ... +70 °C
List of Standards	EN 60079-15:2010 EN 60079-0:2012 EN 60079-11:2012
Optical power emission	OZD 485 G12 PRO: 5 mW max. (820 nm) OZD 485 G12-1300 PRO: 2 mW max. (1300 nm)

DO NOT OPEN WHEN ENERGIZED  
7 POLE CONNECTOR:  
DO NOT SEPERATE WHEN ENERGIZED

### Installation instructions:

The OZD 485 G12(-1300) PRO modules shall be used in an area with a classification of no more than pollution degree 2 and conforming to IEC 60664-1.

The OZD 485 G12(-1300) PRO modules shall be installed in an enclosure with a tool-removable cover that complies with the relevant requirements of EN 60079-15, rated at least IP54.

The Fault contacts shall be installed as non-incendive in accordance with the Control Drawing No. 000100622DNR for ATEX Zone 2 in this document.

The modules shall be connected to supply circuits where the rated voltage cannot exceed the threshold of 119 V due to transient disturbances.

The pictures show two alternatives by external installation.

Max. line length, depending on cross section area:  
200 mm at 0.5 mm<sup>2</sup>  
400 mm at 1.0 mm<sup>2</sup>  
800 mm at 2.0 mm<sup>2</sup>

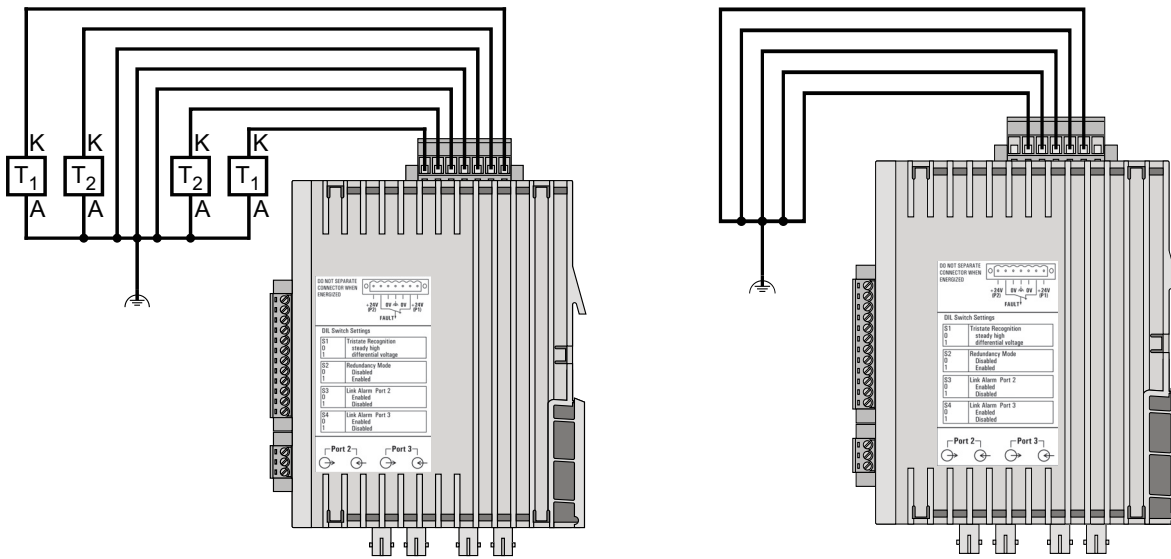

T<sub>1</sub>: Transient voltage protection, not exceeding 119 V, shall be provided at the power supply terminal of the apparatus.

Example: for 24 V power supply you can use P4KE30A or P6KE30A.

T<sub>2</sub>: Prevent between 0 V pin or fault pins of 7 pole connector and earth/frame transient voltages greater than 119 V peak, e.g. by overvoltage limiters (T2) or short circuits (see pictures).



5.3 Control Drawing

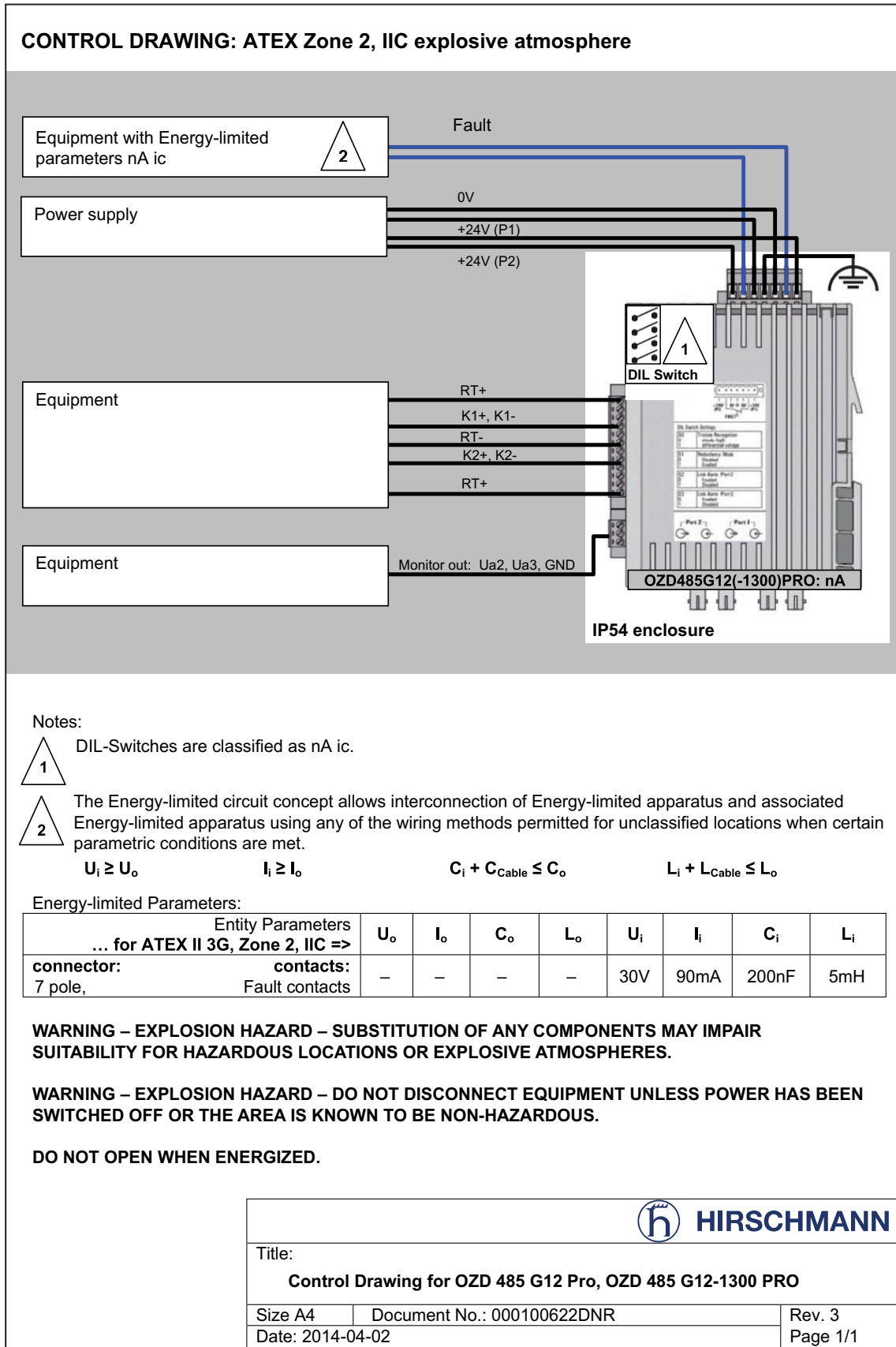

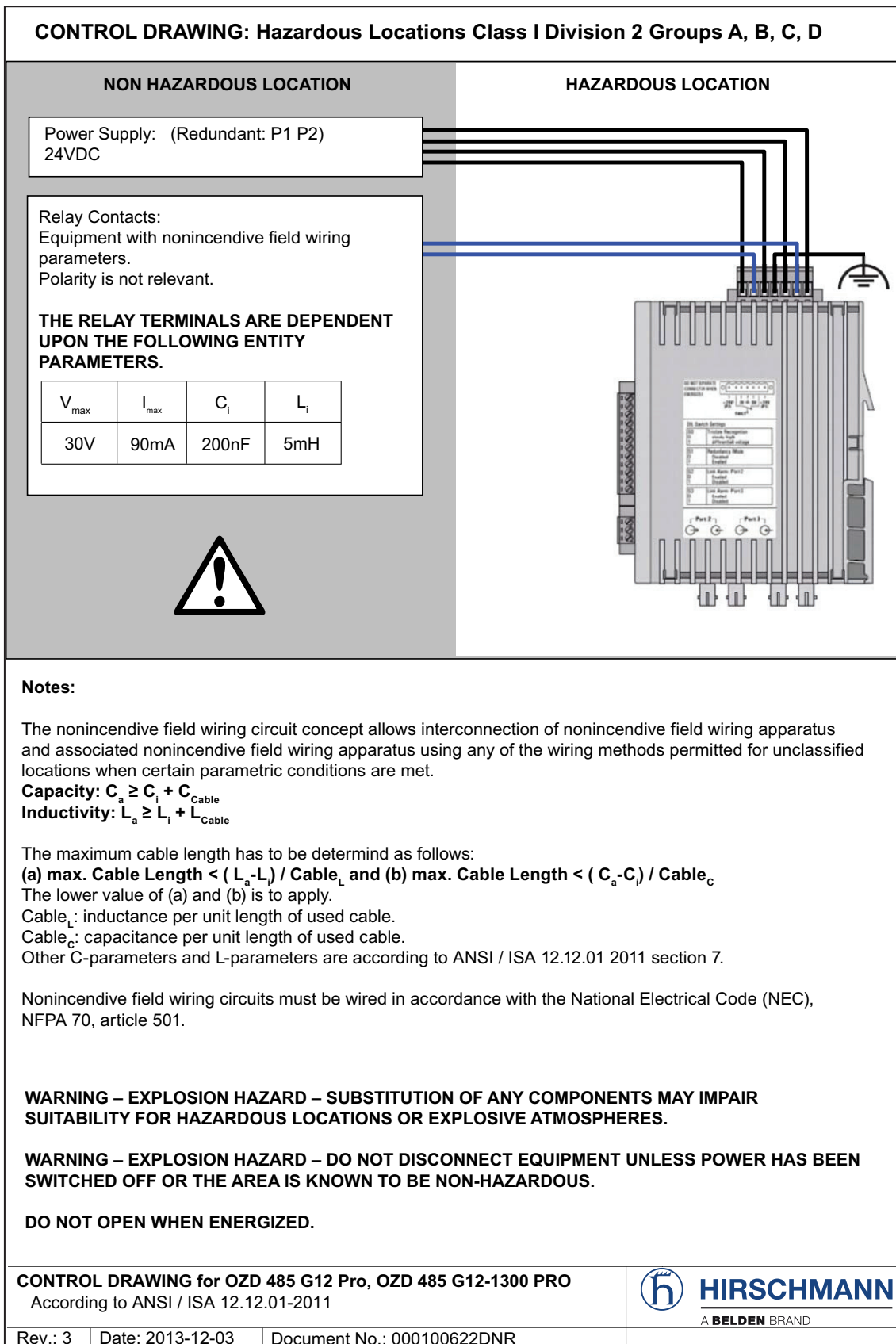

## 5.4 Use in North America

### Relevant information for North America:

- ▶ Only for connection with a Class 2 power supply.
- ▶ For use in Class 2 Circuits.
- ▶ Use 90 or 90°C copper (CU) wire only.

### Additional Information for Use in Hazardous Locations:

**This product may be operated in hazardous locations only if the product label is marked accordingly.**

**The following information applies when operating this equipment in hazardous locations:**

Products marked "Class I, DIV 2, Group A, B, C and D" are suitable for use in Class I Division 2 Groups A, B, C, D, Hazardous Locations and nonhazardous locations only.

Each product is supplied with markings on the rating nameplate indicating the hazardous location temperature code.

When combining products within a system, the most adverse temperature code (lowest "T" number) may be used to help determine the overall temperature code of the system. Wiring must be in accordance with Class I Div. 2 wiring methods and in accordance with the authority having jurisdiction.

- ▶ The peripheral equipment must be suitable for the location in which it is used.
- ▶ These devices must be installed as non-incendive according to the Control Drawing No. 000100622DNR / Class 1 Div. 2 in this document.
- ▶ These devices are open-type devices that are to be installed in an enclosure according to ANSI/UL50, suitable for the environment in which it is used.

## 5.5 Installation procedure

The RS 485 Fiberoptic Repeater OZD 485 G12(-1300) PRO is installed by the following steps:

- ▶ Installing repeater
- ▶ Installing terminating resistors and (as long as the device is located at the end of the line)
- ▶ If necessary: Install pull-up/pull-down resistors (as long as the device is located at the end of the line)
- ▶ Setting DIL switch
- ▶ Connecting the optical bus cables
- ▶ Connecting the electrical bus cables
- ▶ Connecting the function ground
- ▶ Connecting the signal contact cables (optional)
- ▶ Connecting the analog voltage outputs (optional)
- ▶ Connecting the operating voltage supply
- ▶ Checking the LED indicators

## 5.6 Installing repeater

The Fiberoptic Repeater OZD 485 G12(-1300) PRO can be mounted on a 35 mm DIN rail in accordance with IEC 60715: 1981 + A1: 1995.

- ▶ Install the device in a location where the climatic threshold values specified in the technical data are adhered to.
- ▶ Ensure that there is sufficient room to connect the bus and power supply cabling.
- ▶ Connect the optical fiber line before mounting the repeater as this simplifies the procedure.
- ▶ Mount the repeater on the DIN rail.  
To do this, hang the top latch of the repeater into the DIN rail and press the underside onto the rail - as shown in Fig. 15 - until the latch clicks in.

### Note:

You can remove the repeater from the DIN rail by unlocking the snap lock with a screwdriver, as shown in Fig. 16.

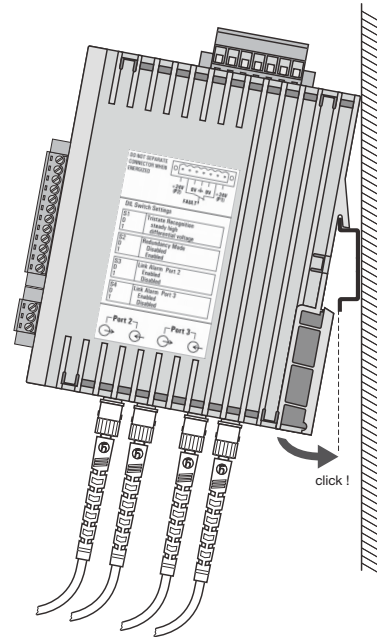

Fig. 15: Mounting a repeater on a DIN rail

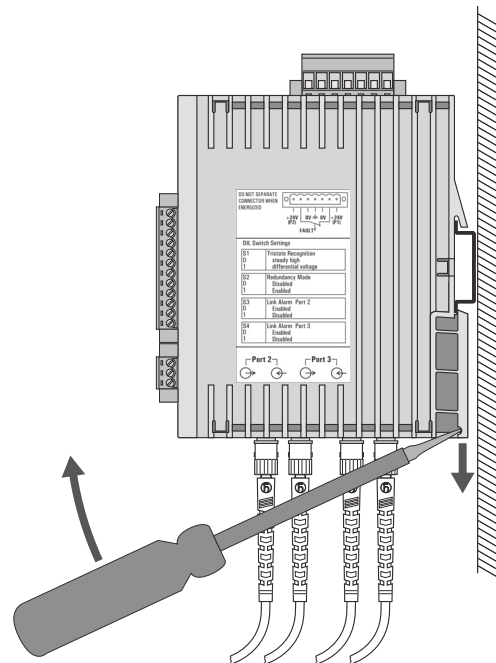

Fig. 16: Removing the repeater from a DIN rail

**5.7 Installing terminating resistor and pull-up/pull-down resistors**

The electrical bus cables must be terminated at the start and end of the line – even for short electrical bus cables – in accordance with the specification of the bus system used (see also chapter 3, page 11).

If there is an OZD 485 G12(-1300) PRO at the start or end of a data line, then the terminating resistor and the pull-up/pull-down resistors (if they exist) can be mounted directly on the repeater.

Tristate identification through permanent high is based on a terminating resistor and pull-up/pull-down resistors (see Fig. 17), while tristate identification through differential voltage is based on characteristic impedance (see Fig. 18) .

Recommended resistor type:  
load capacity 1/3 W, tolerance 5%

Note on the illustrations on the right:  
Only channel 1 is used in the illustrations. If channel 2 is also used, it must be terminated in the same way.

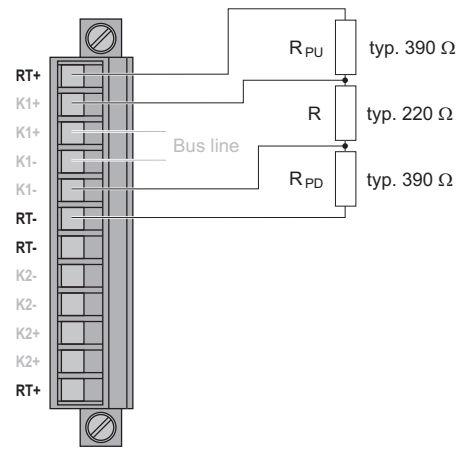

Fig. 17: Termination on the 12-pin screw terminal block for tristate identification through permanent high (terminating resistor and pull-up/pull-down resistors)

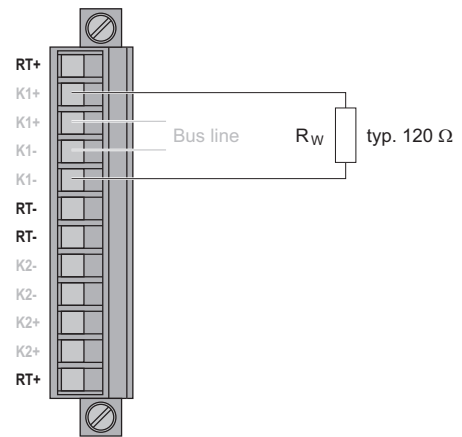

Fig. 18: Termination on the 12-pin screw terminal block for tristate identification through differential voltage (characteristic impedance)

## 5.8 Setting DIL switches

- Set the DIL switches S1 to S4 according to your requirements.

### Note:

You may change the settings of the DIL switches during operation. However, this causes the repeater to be reset and thus to a network interruption of max. 1.5 s and to error messages from other OZD 485 G12(-1300) PRO in the network.

After the reset the new configuration is taken over by the device.

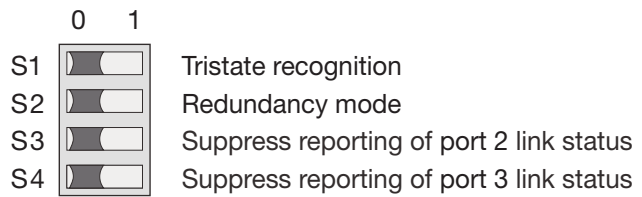

Fig. 19: Overview of DIL switches S1 to S4 on the front panel (settings on delivery)

Switch	Switch position		Remark
	0	1	
S1	Tristate recognition through permanent high	Tristate recognition through differential voltage	Simultaneous switching for both data channels
S2	Redundancy mode is not activated	Redundancy mode is activated	
S3	Too low input power at optical port 2 signaled by the signal contact	Too low input power at optical port 2 not signaled by the signal contact	
S4	Too low input power at optical port 3 signaled by the signal contact	Too low input power at optical port 3 not signaled by the signal contact	

### 5.9 Connecting the optic bus cables

- ▶ Connect the individual repeaters using a duplex F/O cable with BFOC/2.5 (ST<sup>®</sup>) connectors.
- ▶ Note the maximum length of the F/O cables and the possible fiber types specified in the technical data.
- ▶ Ensure that one optical input  $\odot$  and one optical output  $\ominus$  are connected to one another (crossover connection). The sticker on the side indicates the related BFOC sockets of the two ports.
- ▶ Ensure that the strain relief of the F/O cables is sufficient and observe their minimum bend radiuses.
- ▶ Seal unused BFOC sockets with the protection caps supplied. Ambient light can interfere with the network, especially if the environment is very bright. Dust which gets in can render the optical components unusable.

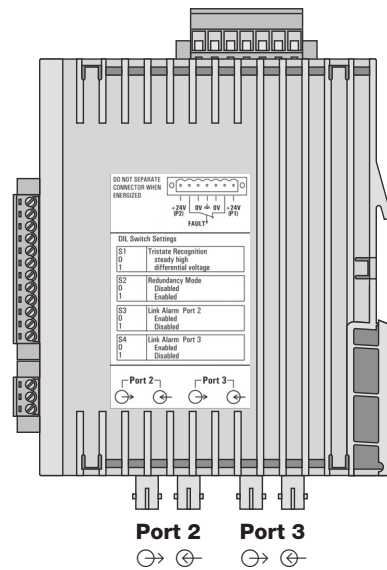

Fig. 20: Location of optical ports 2 and 3, with their respective inputs and outputs

### 5.10 Connecting the electric bus cables

- ▶ The bus cables are connected by means of the plugable screw terminal block on the front of the device.
- ▶ To connect the cables, loosen the screws on the top section and remove it. After connecting the bus cables and then plugging them in, do not forget to re-fasten the screw terminal block.

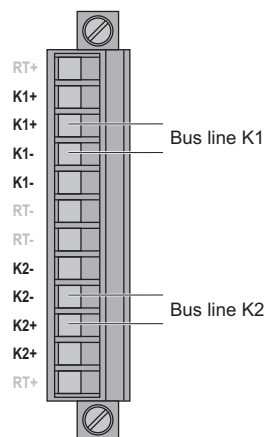



Fig. 21: Connecting the bus cables to the 12-pin screw terminal block

## 5.11 Connecting the function ground



There is no contact separation between the bus lines and the connection for the function ground. Therefore please observe the following safety instructions:

- ▶ Do not use bus lines to connect repeaters to device parts which have a different earth potential. The different voltages could destroy the repeaters!
- ▶ Do not connect bus lines which are partly or entirely laid outside buildings. If lightning strikes close by, this could destroy the repeaters. Use F/O cables for bus connections outside buildings!

- ▶ The shield of the data cable, together with the function ground connection, must be connected to an equipotential rail in the switch cabinet. The equipotential rails of the switch cabinets, which are connected to one another by means of an electrical RS 485 bus cable, must have a low-impedance connection to one another.
- ▶ The function ground of the repeater is effected by means of the  connection of the screw terminal block on top of the device.

## 5.12 Connecting the signal contact lines (optional)

- ▶ On the 7-pin terminal block on the top of the repeater, the unconnected pins of a relay can be used as signal contacts. When the OZD 485 G12(-1300) PRO is working correctly, the contact is closed. If there is an error or a power failure, the contact is opened.
- ▶ The following problems with the network and the repeater can be signalled by means of the signal contact:

### Supply voltage

- interrupted

### Internal device errors

### Received data

- no input signal at port 2
- no input signal at port 3

### Redundancy manager

- RM-LED yellow blinking (Possible causes see chapter 7.1, page 39)

- ▶ Threshold values of relay contact
  - maximum switching voltage: 32 V
  - maximum switching current: 90 mA
  - (for non-hazardous locations only: 1 A, max switching capacity 30 W)

- ▶ The voltage connected to the relay must correspond to a **safety extra-low voltage (SELV)** in accordance with IEC/EN 60950-1
- ▶ Please be sure to use the correct pin assignment for the 7-pin terminal block. Make sure that the electrical insulation of the connection cables of the signal contacts is sufficient. Incorrect connections can destroy the repeater.

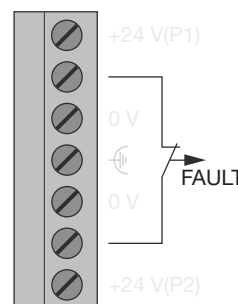

Fig. 22: Signal contact – pin assignment on the 7-pin terminal block



**5.13 Connecting the analog voltage outputs (optional)**

- ▶ The device has two analog voltage outputs, Ua2 and Ua3, each of which supplies a short-circuit-proof output voltage dependent on the optical power input at port 2 or port 3, for diagnosis purposes, in the range from 0 - 5 V (each with reference to "GND" of the 3-pin terminal block).
- ▶ These voltage outputs are connected using a 3-pin screw terminal on the front side of the repeater. The screw terminal is suitable for cable leads that have a cross section between 0.2 - 2.5 mm<sup>2</sup>.

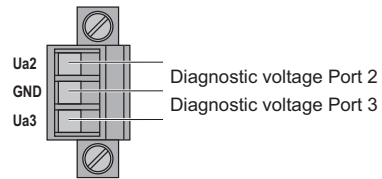

Fig. 23: Analog voltage outputs – connections for 3-pin terminal block

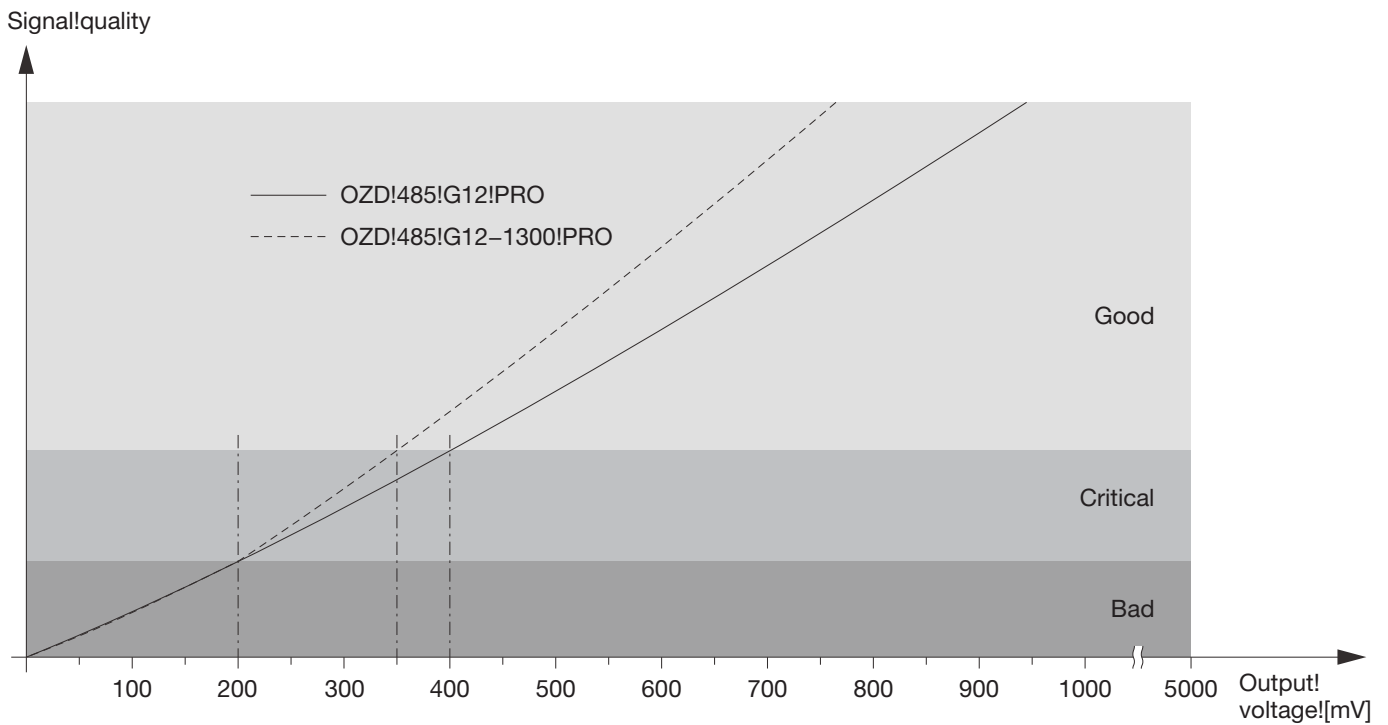

Fig. 24: Relationship between the output voltage at the terminals Ua2 and Ua3 and the optical input power at port 2 and port 3

## 5.14 Connecting the operating voltage supply

- ▶ Only supply the repeater with a stabilized **safety extra-low voltage (SELV)** in accordance with IEC/EN 60950-1/VDE 0805, maximum +24 VDC (for non-hazardous locations only: 32 VDC max.). It is supplied via the 7-pin terminal block on the top of the repeater.
- ▶ To improve the operating safety, a redundant operating power supply consisting of separate sources can be used. You can input the voltage supply in two ways:
  - terminal +24 V (P1) of the terminal block
  - terminal +24 V (P2) of the terminal block

The minus connection for each is indicated by “0 V”.

**Note:** In the case of non-redundant operating voltage supply from only one source, the two terminals +24V(P1) and +24V(P2) should be connected in order to avoid signaling the system LED and the signal contact.

- ▶ The two voltages can have any values – even different ones – within the specified limits. However, there is no load distribution. If necessary, the power supply unit with the higher output voltage must supply the power alone.
- ▶ The operating voltage(s) are electrically isolated from the function ground connection and from the other connections.

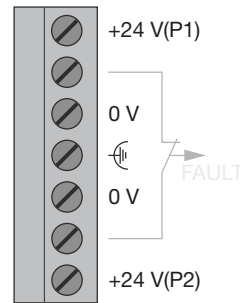

Fig. 25: Operating voltage supply – pin assignment on the 7-pin terminal block

## 5.15 Checking the LED indicators

- ▶ There are LEDs on the front of the device for diagnostic purposes. They are explained in chapter 7.1, p. 35.

## 6 Bus configurations

### 6.1 BITBUS

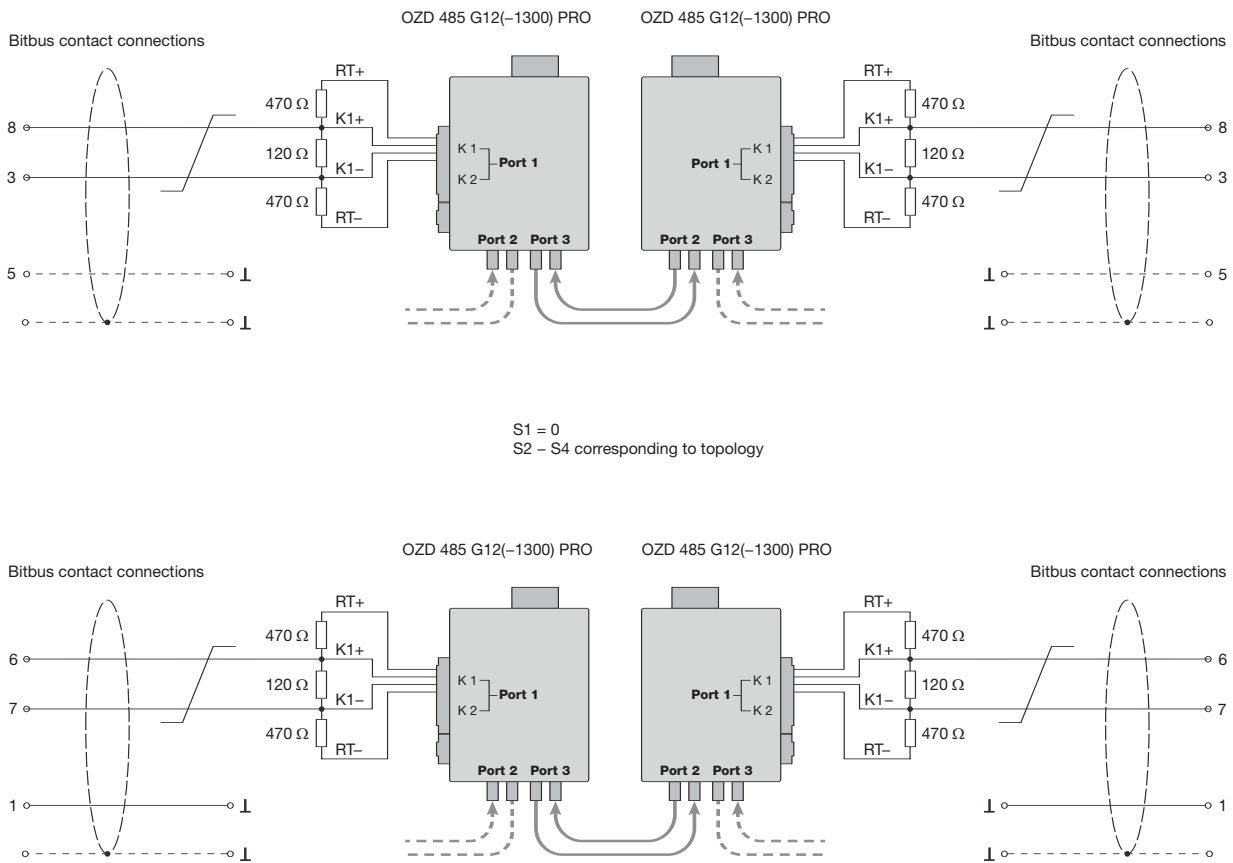

Fig. 26: Example of connection of OZD 485 G12(-1300) PRO to bitbus with twisted pair cable type A (above) or type B (below). The PIN numbers on the ends of the lines refer to the 9-pin sub-D connections prescribed in the standard.

6.2 DIN measurement bus

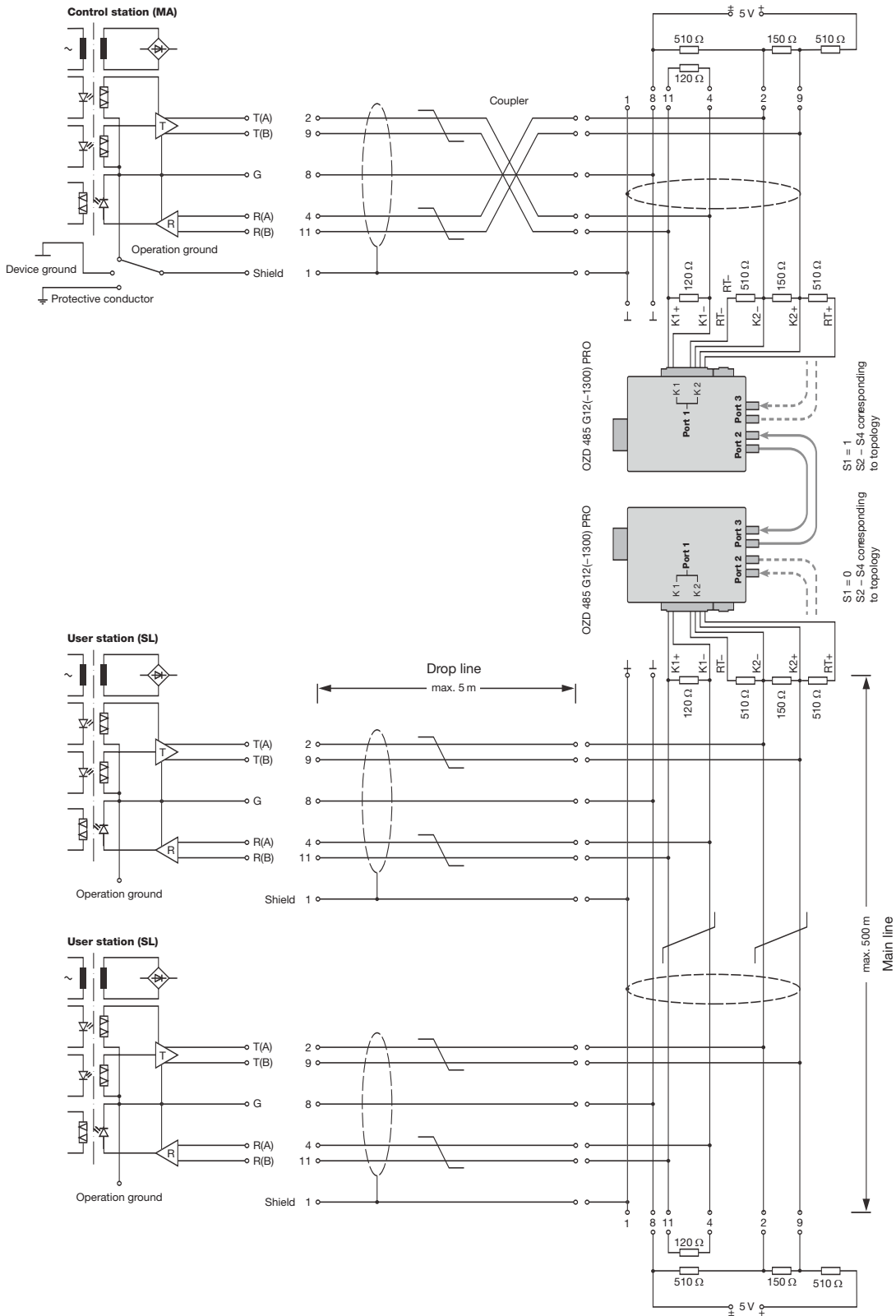

Fig. 27: Example of connection of OZD 485 G12(-1300) PRO to DIN measurement bus. The PIN numbers on the ends of the lines refer to the 15-pin sub-D connections used in the standard DIN 66348.

## 6.3 InterBus-S

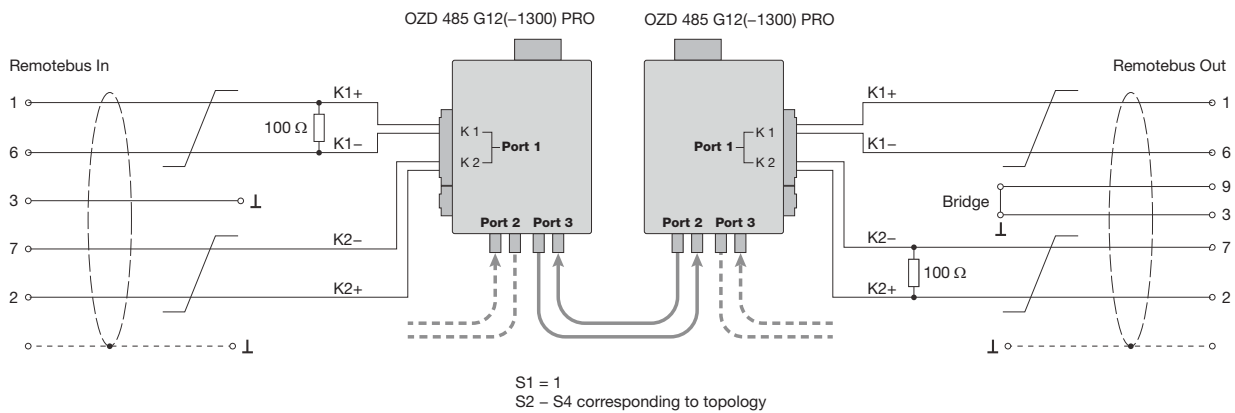

Fig. 28: Example of connection of OZD 485 G12(-1300) PRO to InterBus-S.

The PIN numbers on the ends of the lines refer to the 9-pin sub-D connections used by the PHOENIX CONTACT company.

## 6.4 Modbus RTU/Modbus ASCII

The RS 485 Fiberoptic Repeater OZD 485 G12(-1300) PRO supports Modbus RTU and Modbus ASCII with RS 485 interfaces up to a maximum data rate of 1.5 MBit/s NRZ.

### Note:

Modbus Plus is **not** supported by the OZD 485 G12(-1300) PRO !  
The Hirschmann Fiberoptic Repeater OZD Modbus Plus G12(-1300) is a suitable repeater for Modbus Plus.

### Note:

With the aid of the flow diagram on page 34, you can specify the connection examples suitable for your application from page 35.

### 6.4.1 Specification of the Modbus variants

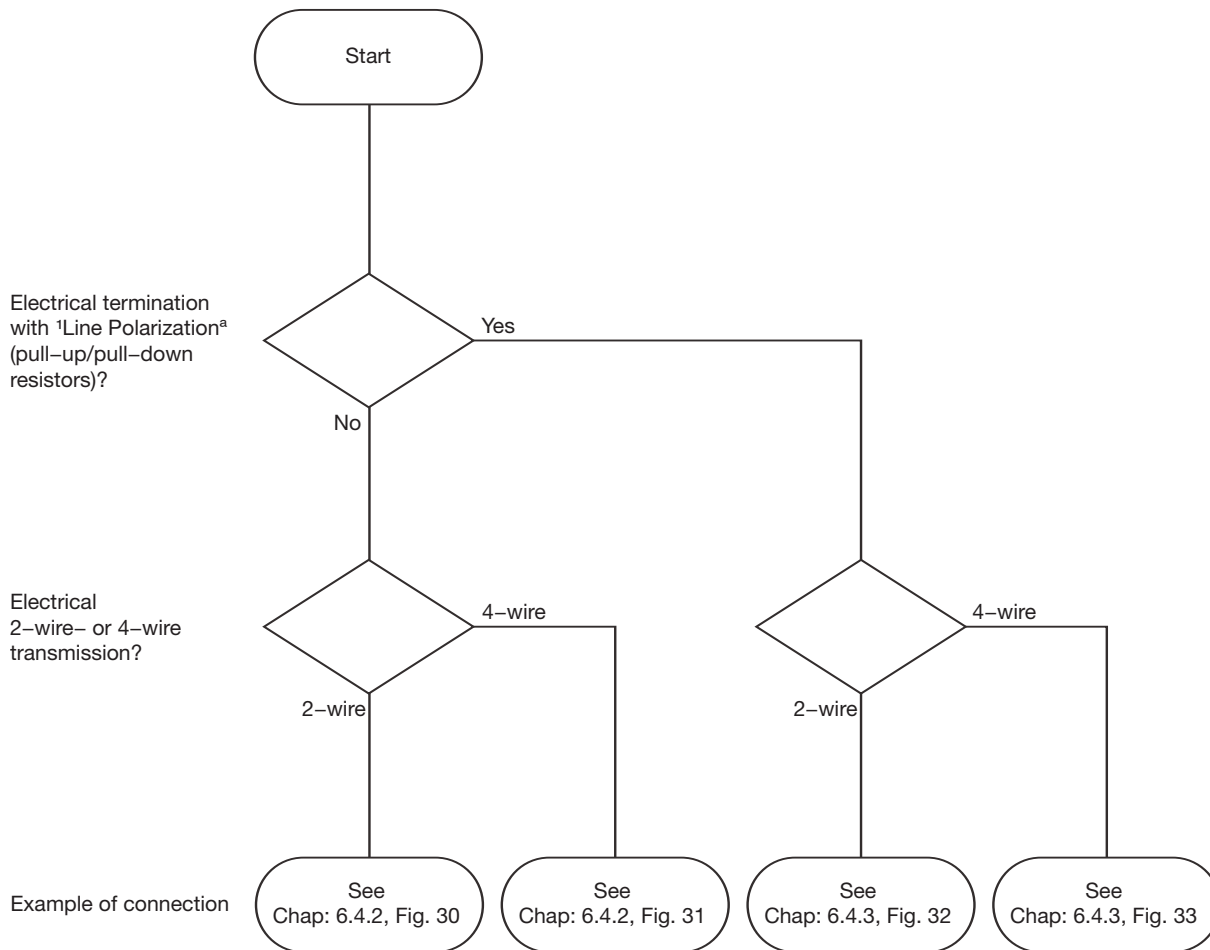

Fig. 29: Flow diagram for the specification of the connection example suited to the current application

### 6.4.2 Without Line Polarization

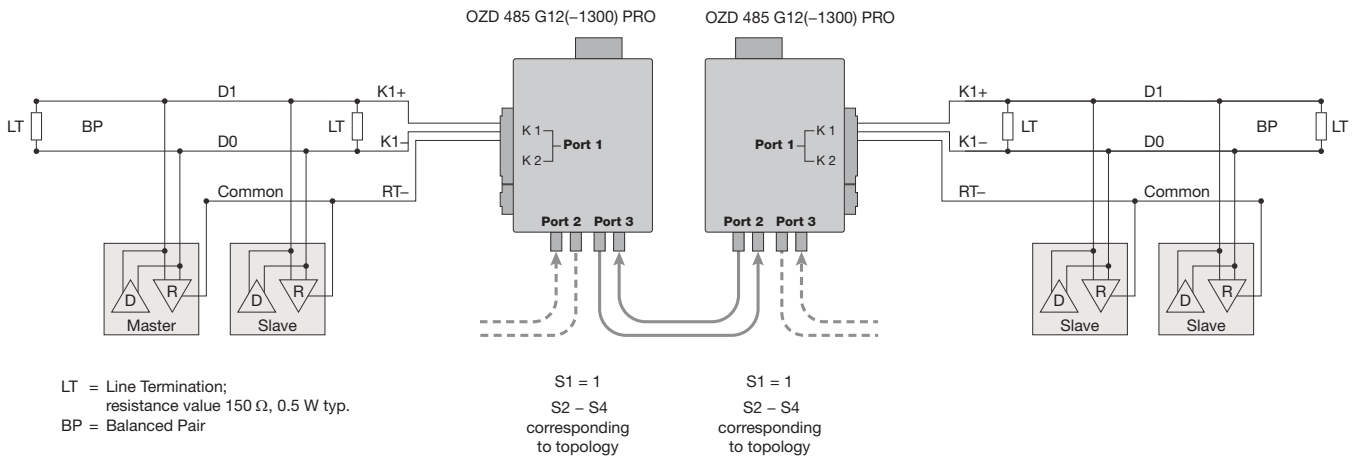

Fig. 30: Example of connection of OZD 485 G12(-1300) PRO to Modbus RTU/Modbus ASCII without Line Polarization for 2-wire transmission

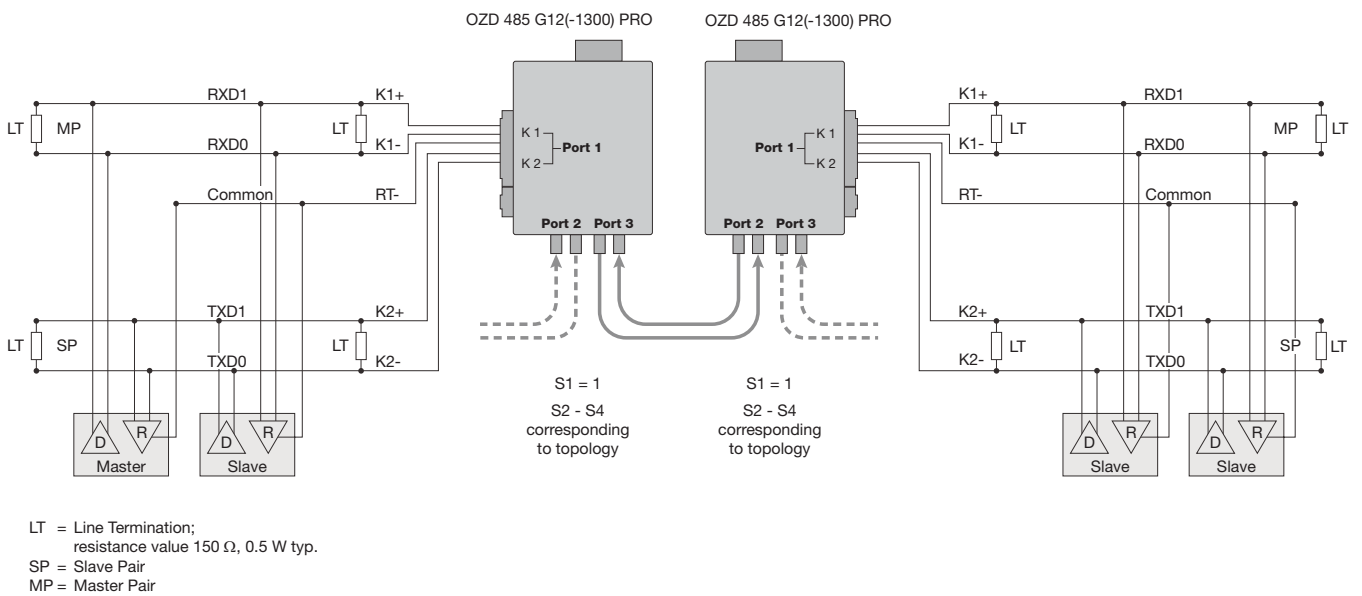

Fig. 31: Example of connection of OZD 485 G12(-1300) PRO to Modbus RTU/Modbus ASCII without Line Polarization for 4-wire transmission

6.4.3 With Line Polarization

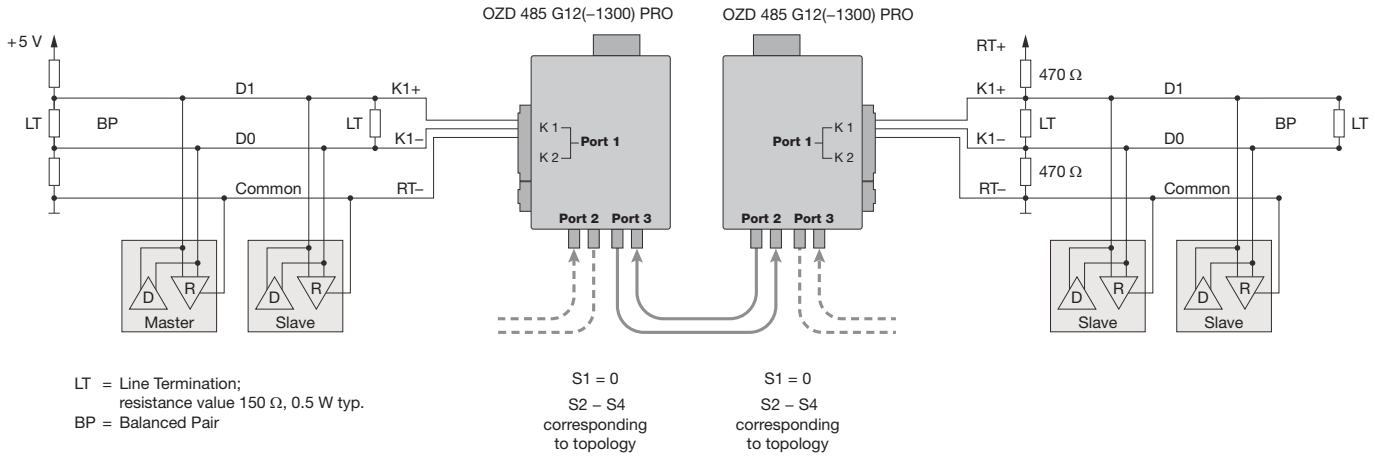

Fig. 32: Example of connection of OZD 485 G12(-1300) PRO to Modbus RTU/Modbus ASCII with Line Polarization for 2-wire transmission

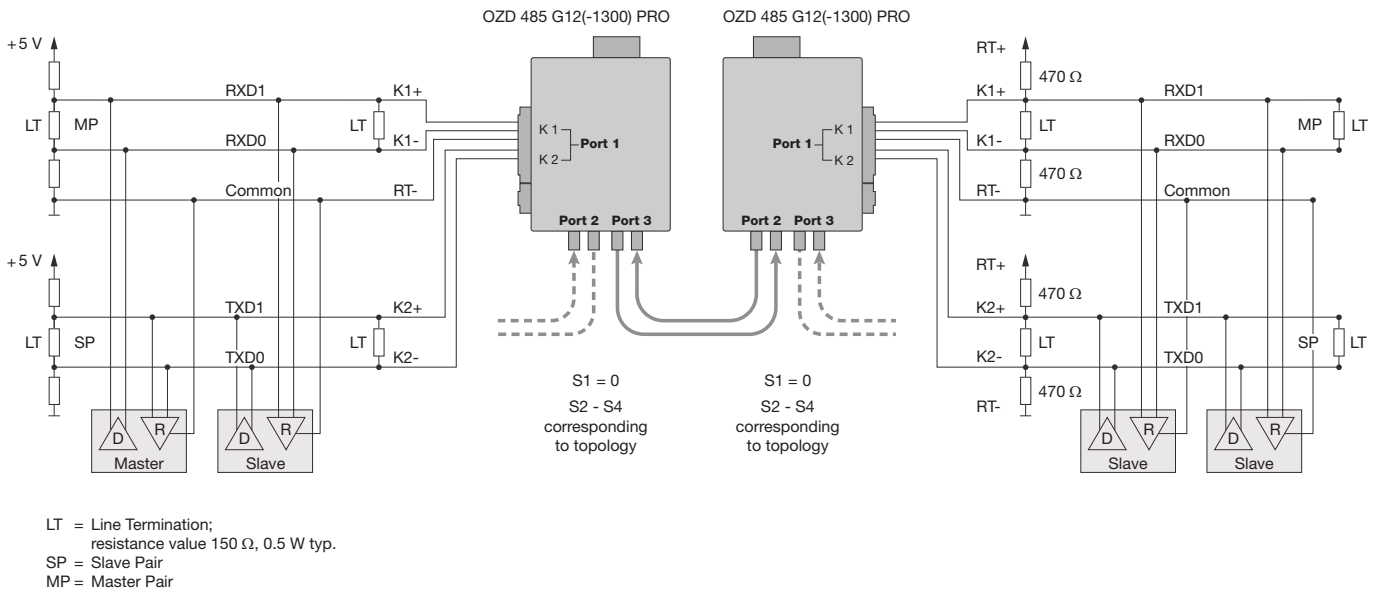

Fig. 33: Example of connection of OZD 485 G12(-1300) PRO to Modbus RTU/Modbus ASCII with Line Polarization for 4-wire transmission



## 6.5 Configuration of other bus systems

If you are using a collision-free RS 485 bus other than those named in chapters 6.1 to 6.4 (e.g. SattBus, Uni-Telway, Saia S-Bus, DH-485, SUCOnet K, ...), please clarify which termination the bus system has and – derived from this – the type of tristate identification.

Comment:

All data rates from 0 - 1.5 Mbit/s NRZ are supported.

Should you need additional support, please contact our Service Center (for address, see chapter 7.4, page 42).



## 7 Help with problems

### 7.1 LED displays

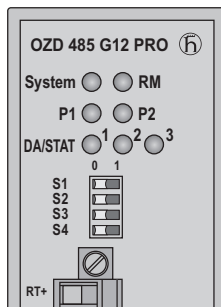

Fig. 34: LED indicators on the front panel

LED display	Possible causes	Signal contact
<b>System</b> <ul style="list-style-type: none"> <li>■ green</li> <li>■ off</li> <li>■ red</li> </ul>	<ul style="list-style-type: none"> <li>– Repeater operating correctly</li> <li>– Supply voltage interrupted</li> <li>– Internal device error</li> <li>– Signal contact indicates error because               <ul style="list-style-type: none"> <li>– there is only one supply voltage P1 or P2</li> <li>Remedy: connect second supply voltage or make a bridge between terminal +24V(P1) and +24V(P2)</li> <li>– no optical input signal at port 2 and/or port 3</li> <li>Remedy: – If port 2 is not occupied, set S3 to “1”                   <ul style="list-style-type: none"> <li>– If port 3 is not occupied, set S4 to “1” or</li> <li>– Check relevant F/O line</li> </ul> </li> <li>– RM-LED blinking yellow (for possible causes, see „LED display RM“) below</li> </ul> </li> </ul>	<ul style="list-style-type: none"> <li><u>No signal</u></li> <li><u>Signal</u></li> <li><u>Signal</u></li> </ul>
<b>P 1</b> <ul style="list-style-type: none"> <li>■ green</li> <li>■ off</li> </ul>	<ul style="list-style-type: none"> <li>– Supply voltage 1 ok</li> <li>– Supply voltage 1 too low</li> </ul>	<ul style="list-style-type: none"> <li><u>No signal</u></li> <li><u>Signal</u></li> </ul>
<b>P 2</b> <ul style="list-style-type: none"> <li>■ green</li> <li>■ off</li> </ul>	<ul style="list-style-type: none"> <li>– Supply voltage 2 ok</li> <li>– Supply voltage 2 too low</li> </ul>	<ul style="list-style-type: none"> <li><u>No signal</u></li> <li><u>Signal</u></li> </ul>
<b>RM</b> <ul style="list-style-type: none"> <li>■ green</li> <li>■ yellow</li> <li>■ yellow blinking</li> <li>■ off</li> </ul>	<ul style="list-style-type: none"> <li>– Redundancy mode activated, no error detected in ring, redundant port not active</li> <li>– Redundancy mode activated, error detected in ring, redundant port active</li> <li>– Redundancy mode activated, error detected in ring, redundant port not active because               <ul style="list-style-type: none"> <li>– a second OZD 485 ... in redundant mode or</li> <li>– an OZD 485 G12 BAS has been detected in the Ring</li> </ul> </li> <li>– Redundancy mode not activated</li> </ul>	<ul style="list-style-type: none"> <li><u>No signal</u></li> <li><u>No signal</u></li> <li><u>Signal</u></li> <li><u>No signal</u></li> </ul>

<b>DA/STAT 1</b>	■ yellow	– Data received at port 1 (Channel 1 or 2)	<u>No signal</u>
	■ off	– No input signal at port 1	<u>No signal</u>
<b>DA/STAT 2</b>	■ green	– Optical input power at port 2 ok	<u>No signal</u>
	■ yellow	– Optical data received at port 2 (Channel 1 or 2)	<u>No signal</u>
	■ off	– No input signal at port 2	<u>Signal <sup>1)</sup></u>
<b>DA/STAT 3</b>	■ green	– Optical input power at port 3 ok	<u>No signal</u>
	■ yellow	– Optical data received at port 3 (Channel 1 or 2)	<u>No signal</u>
	■ off	– No input signal at port 3	<u>Signal <sup>2)</sup></u>

<sup>1)</sup> If S3 in position "0" (see 5.8, page 26)

<sup>2)</sup> If S4 in position "0" (see 5.8, page 26)

## 7.2 Troubleshooting

If your RS485 network is not working correctly with OZD 485 G12(-1300) PRO, please check the following points:

- ▶ Try using the LED indicators ( see chapter 7.1, page 39) to find possible causes and try to resolve them.
- ▶ Are all the electrical bus lines terminated at both ends in accordance with the specifications of the bus system being used (even for short electrical bus lines)?
- ▶ Is the DIL switch S1 set in accordance with the specified termination of the bus system being used (see chapter 5.8, page 26)?
- ▶ Is the shielding (see chapter 5.1, page 19 and 5.11, p. 28) connected?
- ▶ Is the function ground (see chapter 5.11, page 28) connected?
- ▶ Are the lengths of the optical fibers within the specified value range (depends on device and glass fiber being used)? See chapter 8, p. 43.
- ▶ Is the reception level of the optical ports within the permissible range? See chapter 5.13, p. 29.
- ▶ Are the DIL switches S2, S3 and S4 set correctly with regard to the topology (see chapter 5.8, page 26)?  
Line topology/Star topology:
  - DIL switch S2 (redundancy mode) for **all** repeaters on "0"
  - DIL switch S3 or S4 (suppress reporting of link status) on "1" for the repeaters with unoccupied optical ports (at start and end of line)
 Redundant ring:
  - DIL switch S2 (redundancy mode) for **one** repeater on "1" and for all others on "0"
  - DIL switches S3 and S4 (suppress reporting of link status) on "0"

## 7.3 Problem reporting

If the transmission in the RS485 network is still not satisfactory after all the points in chapter 7.2 have been clarified, then please send answers to the following questions and the documents requested to our service hotline (for contact address, see chapter 7.4, page 42):

1. Exact type designation of the OZD 485 G12(-1300) PRO. For identification purposes, please provide the order number printed on the device (18 digits).
2. Does the bus system to be transferred in the physical interface correspond to the standard RS 485?
3. Does the bus access procedure of the bus system used ensure that at any given time only one participant can access the bus?  
**Warning!** Access procedures where there is a risk of collisions (e.g. CAN) are not permissible!
4. What type of tristate identification is being used by the bus system (permanent high or differential voltage - see chapter 3, page 11)?
5. Is the field bus system operating in “half-duplex” or “full-duplex” mode?
6. Give as detailed a description of the error as possible in your own words.
7. Send us a detailed network plan with
  - the fiber type and fiber length,
  - the location and length of the electrical segments,
  - the values, the type (characteristic impedance with or without pull-up and pull-down resistors) and the position of the termination on the electrical bus segment.

8. What data rate is being used?
9. How are the DIL switches set for the individual OZD 485 G12(-1300) PRO?
10. What is the status of the LEDs on the relevant OZD 485 G12(-1300) PRO?
11. Please provide the voltage values of the analog voltage outputs (terminal Ua2 and Ua3 on the 3-pin terminal block on top of the device) for the relevant ports.
12. Name and manufacturer of the field bus system?

### Important!

If you do not provide complete answers to questions 1 to 12, we cannot process your query!

### Note:

You can get the current version of this manual on the Internet at <http://www.hirschmann.com/> via the product search at the product.

You will find the version of this manual on every page of the manual, at the bottom opposite the page number.

## 7.4 Contact address

### Contact address for technical support

Hirschmann Automation and Control GmbH  
Stuttgarter Straße 45 – 51  
72654 Neckartenzlingen  
Germany

Tel.: +49 (0) 1805 14-1538

Fax: +49 (0) 7127 14-1551

Email: [HAC.Support@Belden.com](mailto:HAC.Support@Belden.com)

Internet: <http://www.hirschmann.com>

## 8 Technical Data

<b>Repeater</b>	<b>OZD 485 G12 PRO</b>	<b>OZD 485 G12-1300 PRO</b>
<b>Order No.</b>	<b>943 894-321</b>	<b>943 895-321</b>
<b>Voltage/power supply</b>		
Operating voltage	NEC Class 2 power source 18 ... 24 VDC safety extra-low voltage (SELV/PELV); (for non-hazardous locations only: 18 ... 32 VDC), redundant inputs decoupled, buffer time min. 10 ms at 24 VDC	
Current consumption	200 mA	
Power consumption	3.5 W	
Signal contact		
Maximum switching voltage	32 V (safety extra-low voltage), electrically isolated from the housing and all electrical connections	
Maximum switching current	1.0 A	
<b>Signal transmission</b>		
Transmission speed	0 ... 1.5 Mbit/s NRZ	
Signal processing time (any input/output)	<1.33 µs	
Reconfiguration time of redundancy manager	0.4 ms typ. (1.4 ms max. )	
<b>Electrical port</b>		
Input signal with tristate recognition		
– through permanent high	RS 485 level	
– through differential voltage Low	< -0.7 V	
Tristate	-0.1 V bis +0.1 V	
High	> + 0.7 V	
Output signal in both operating modes	RS 485 level	
Connection capability	max. 31 terminal devices for each electrical segment	
<b>Optical interface</b>		
Wavelength typ.	860 nm	1310 nm
Launchable optical power		
– in fiber E 10/125	–	–18 dBm
– in fiber G 50/125	–20 dBm	–13 dBm
– in fiber G 62.5/125	–16 dBm	–13 dBm
Receiver sensitivity	–30 dBm	–31 dBm
Transmission distance with 2 dB <sup>1)</sup> or 3 dB <sup>2)</sup> system reserve/line attenuation		
– with fiber E 10/125 (0.5 dB/km)	–	0 - 22 km/13 dB <sup>1)</sup>
– with fiber G 50/125 (1.0 dB/km)	–	0 - 16 km/18 dB <sup>1)</sup>
– with fiber G 62.5/125 (1.0 dB/km)	–	0 - 16 km/18 dB <sup>1)</sup>
– with fiber G 50/125 (3.0 dB/km)	0 - 2.3 km/10 dB <sup>2)</sup>	–
– with fiber G 62.5/125 (3.5 dB/km)	0 - 3.1 km/14 dB <sup>2)</sup>	–
Optical connector	BFOC/2.5 (ST <sup>®</sup> )	

Repeater	OZD 485 G12 PRO	OZD 485 G12-1300 PRO
Order No.	943 894-321	943 895-321
<b>Electromagnetic compatibility (EMC)</b>		
Interference immunity for industry in accordance with EN 61000-6-2:2001		
Electrostatic discharging (ESD)	conforms to EN 61000-4-2; 4 kV contact discharge, 8 kV air discharge	
Electromagnetic field	conforms to EN 61000-4-3; 10 V/m (80 MHz - 1000 MHz, 1400 MHz -2000 MHz)	
Fast transients (burst)	conforms to EN 61000-4-4; 2 kV power line, 1 kV data line	
Voltage surge	conforms to EN 61000-4-5; 1 kV data line, 1 kV power line symmetrical, 1 kV power line asymmetrical	
Line-conducted interference voltages	conforms to EN 61000-4-6; 10 V (150 kHz - 80 MHz)	
Emitted interference	conforms to EN 55022; Class A conforms to FCC CFR47 Part 15; Class A	
<b>Climatic ambient conditions</b>		
Ambient temperature	-25 °C to +70 °C (IEC 60068-2-1, IEC 60068-2-2)	
Storage temperature	-25 °C to +80 °C (IEC 60068-2-14)	
Relative humidity	<95 %, non-condensing (IEC 60068-2-30)	
Air pressure	during operation: up to 2000 m (795 hPa) transport and storage: up to 3000 m (700 hPa)	
Contamination level	2	
<b>Mechanical ambient conditions</b>		
Vibrations	3 to 9 Hz, 3.5 mm amplitude (IEC 61131-2); 9 to 150 Hz, 1 g acceleration (IEC 61131-2)	
Shock	15g, 11 ms duration, 18 shocks (IEC 61131-2)	
Protection class	IP 20	
Weight	194 g	214 g
Dimensions (W x H x D, with connections)	35 x 156 x 114 mm	35 x 162 x 114 mm
Housing material	Plastic PA6.6, aluminium	







# HIRSCHMANN

---

A **BELDEN** BRAND

Hirschmann Automation and Control GmbH  
Stuttgarter Strasse 45 – 51  
72654 Neckartenzlingen  
Germany

Tel.: +49 (0)1805 14-1538  
Fax: +49 (0)7127 14-1551  
Email: [HAC.Support@Belden.com](mailto:HAC.Support@Belden.com)  
Internet: <http://www.hirschmann.com>