



**HIRSCHMANN**

A **BELDEN** BRAND

# User Manual

## Installation

### Dragon PTN Transmit Receive Module SFP/XFP



The naming of copyrighted trademarks in this manual, even when not specially indicated, should not be taken to mean that these names may be considered as free in the sense of the trademark and tradename protection law and hence that they may be freely used by anyone.

© 2018 Hirschmann Automation and Control GmbH

Manuals and software are protected by copyright. All rights reserved. The copying, reproduction, translation, conversion into any electronic medium or machine scannable form is not permitted, either in whole or in part. An exception is the preparation of a backup copy of the software for your own use.

The performance features described here are binding only if they have been expressly agreed when the contract was made. This document was produced by Hirschmann Automation and Control GmbH according to the best of the company's knowledge. Hirschmann reserves the right to change the contents of this document without prior notice. Hirschmann can give no guarantee in respect of the correctness or accuracy of the information in this document.

Hirschmann can accept no responsibility for damages, resulting from the use of the network components or the associated operating software. In addition, we refer to the conditions of use specified in the license contract.

You can get the latest version of this manual on the Internet at the Hirschmann product site ([www.hirschmann.com](http://www.hirschmann.com)).

Hirschmann Automation and Control GmbH  
Stuttgarter Str. 45-51  
72654 Neckartenzlingen  
Germany

## Contents

<b>1.</b>	<b>INTRODUCTION .....</b>	<b>4</b>
<b>1.1</b>	<b>General.....</b>	<b>4</b>
<b>1.2</b>	<b>Manual References .....</b>	<b>4</b>
<b>1.3</b>	<b>Optical Connectors.....</b>	<b>4</b>
<b>1.4</b>	<b>Glossary.....</b>	<b>4</b>
<b>1.5</b>	<b>Optical Attenuator .....</b>	<b>6</b>
<b>2.</b>	<b>SFP MODULES.....</b>	<b>7</b>
<b>3.</b>	<b>XFP MODULES .....</b>	<b>9</b>
<b>4.</b>	<b>CWDM MODULES FOR 1000 MBPS .....</b>	<b>10</b>
<b>5.</b>	<b>DWDM ITU CHANNELS FOR OPTICAL MODULES.....</b>	<b>11</b>
<b>6.</b>	<b>ABBREVIATIONS .....</b>	<b>12</b>

## List of figures

Figure 1 Optical LC Connector .....	4
Figure 2 SDH/SONET over Dragon PTN via Smart SFPs .....	5
Figure 3 SFP/XFP Cages .....	6
Figure 4 Optical Attenuator on Rx Side .....	6

## List of Tables

Table 1 Manual References.....	4
Table 2 Optical SFP Modules on IFMs .....	7
Table 3 Optical Smart SFP Modules on IFMs.....	8
Table 4 Electrical SFP Modules on IFMs .....	8
Table 5 Optical XFP Modules.....	9
Table 6 CWDM Modules for 1000 Mbps: Order Numbers.....	10
Table 7 DWDM ITU Channels for 1 or 10 Gbps , Frequency, Wavelengths .....	11

## 1. INTRODUCTION

### 1.1 General

This document is valid as of Dragon PTN Release 3.0DR.

### 1.2 Manual References

Table 1 is an overview of the manuals referred to in this manual. ‘&’ refers to the language code, ‘\*’ refers to the manual issue. All these manuals can be found in the HiProvision (=Dragon PTN Management System) Help function.

**Table 1 Manual References**

Ref.	Number	Title
[1]	DRA-DRM801-&-*	Dragon PTN Installation and Operation
[2]	DRB-DRM802-&-*	Dragon PTN Nodes: PTN2210, PTN2209, PTN2206, PTN1104
[3]	DRE-DRM807-&-*	Dragon PTN Interface Module: PTN-4-GC-LW/PTN-4-GCB-LW
[4]	DRE-DRM808-&-*	Dragon PTN Interface Module: PTN-1-10G-LW
[5]	DRE-DRM809-&-*	Dragon PTN Interface Module: PTN-C37.94
[6]	DRE-DRM809-&-*	Dragon PTN Interface Module: PTN-4-GO-LW
[7]	DRE-DRM823-&-*	Dragon PTN Interface Module: PTN-9-L3A-L
[8]	DRE-DRM821-&-*	Dragon PTN and HiProvision Operation Manual

### 1.3 Optical Connectors

In Dragon PTN, the LC connector (LC/PC or LC/UPC type) is used for pluggable SFP/XFPs, see figure below.



**Figure 1 Optical LC Connector**

### 1.4 Glossary

Find below some explained terms that are used in the tables further on:

- ▶ **SFP:** The small form-factor pluggable (SFP) is a compact, hot-pluggable transceiver used for both telecommunication and data communications applications. The SFP can be used to interface some IFMs (see tables below) to fiber (=Optical). The SFP is used up to data rate speed of 1 Gbps.
- ▶ **XFP:** The XFP (10 Gigabit Small Form Factor Pluggable) is a standard for transceivers for high-speed (10 Gbps) optical links.
- ▶ **Smart SFP:** Smart SFP is a hot-pluggable optical transceiver that converts incoming STM/OC frames from a fiber-optic SDH/SONET network into Ethernet frames at e.g. the

4-GC-LW front port 1 or vice versa for outgoing frames. As a result, Dragon PTN allows to transparently transport synchronous digital bit streams from an SDH/SONET network. Smart SFP is also called TSoP (Transparent Sonet/SDH over Packet). The available smart SFPs are listed in the tables further on. Smart SFPs need some extra configuration in HiProvision, see Ref. [8] in Table 1.

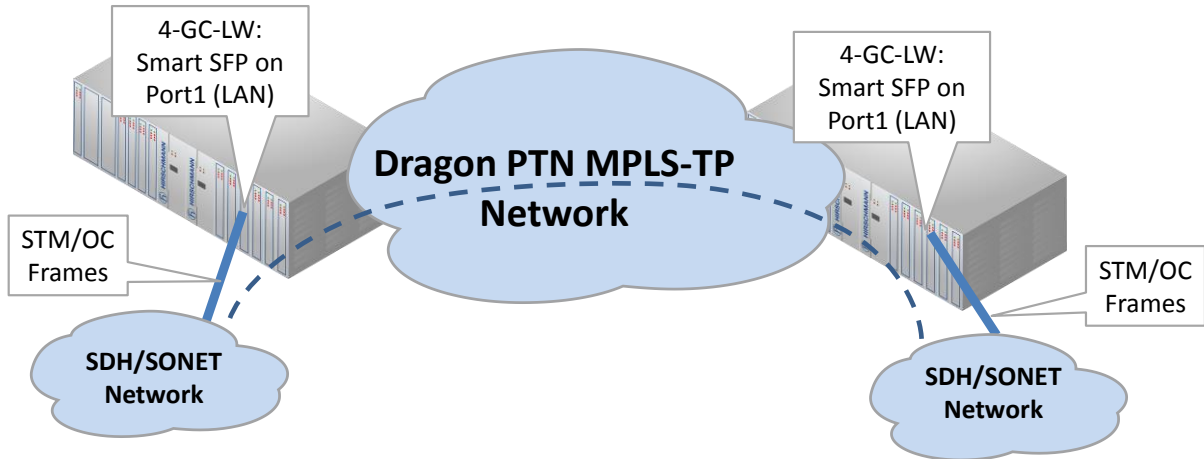

**Figure 2 SDH/SONET over Dragon PTN via Smart SFPs**

- ▶ **Fiber Type:** The fiber type mentioned in the table is the recommended one.
- ▶ **Distance:** The distance that can be travelled by the optical signal over a suited optical fiber; the distances can be found in the tables further on. The distance that can be spanned is a result of multiple factors:
  - ▶ Transceiver optical budget = (Min. Pout – Min. Pin); more info on Pout and Pin, see below;
  - ▶ Link attenuation as a result of connector and splice losses;
  - ▶ Chromatic and modal dispersion causing signal deformation.
- ▶ **Pout:** Average TRM Output Power at the transmit side;
- ▶ **Pin:** Required TRM Input Power at the receiver side to have a valid optical signal. ATTENTION: measure the received input power before connecting the fiber to the TRM receiver. Exceeding 'Pin Max.' (See tables below) could damage the TRM!
- ▶ **Eye Safety:** All mentioned TRMs are class 1 laser products and comply with IEC 825-1, EN60825 and FDA 21 CFR 1040.10.
- ▶ **CWDM:** Coarse Wavelength Division Multiplexing technique multiplexes different optical signals with different wavelengths into one fiber. At the destination, the different optical signals are demultiplexed again into separate optical signals. Wavelength spacing is 20 nm, allowing for cost efficient multiplexers.
- ▶ **DWDM:** Dense Wavelength Division Multiplexing technique multiplexes different optical signals with different wavelengths into one fiber. At the destination, the different optical signals are demultiplexed again into separate optical signals. Wavelength spacing is about 1 nm so allowing for a lot of wavelengths in the useful spectrum of the fiber. As a result DWDM can multiplex a lot more optical signals on the fiber than CWDM.
- ▶ **SFP/XFP Cage:**

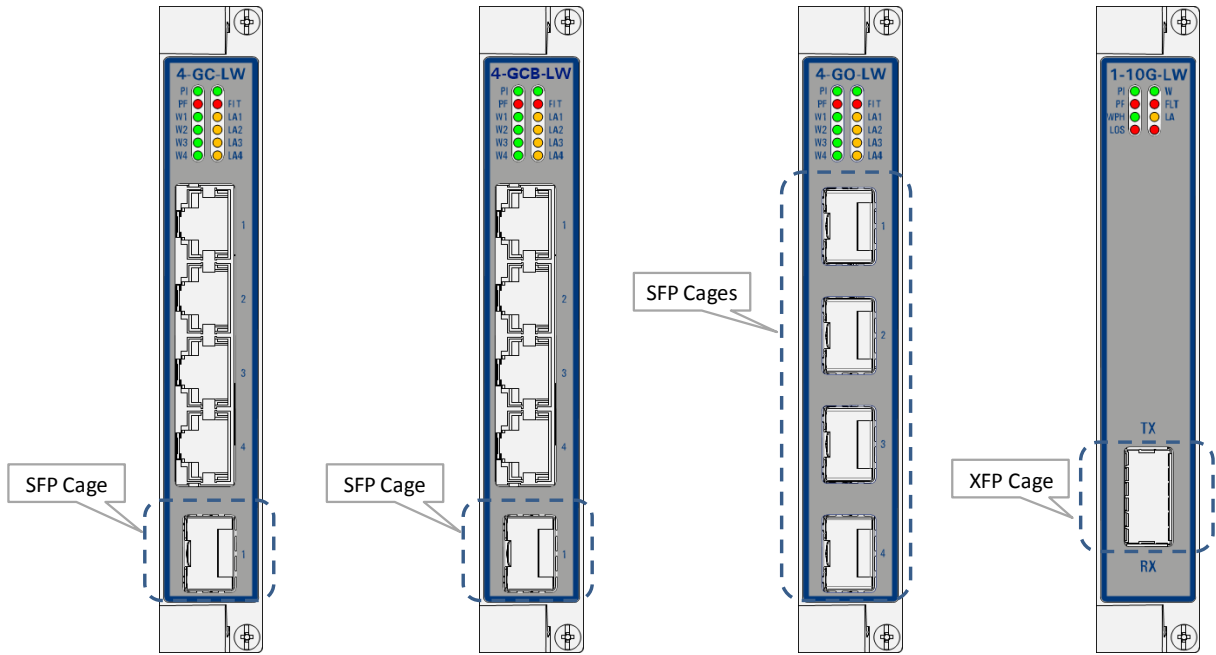
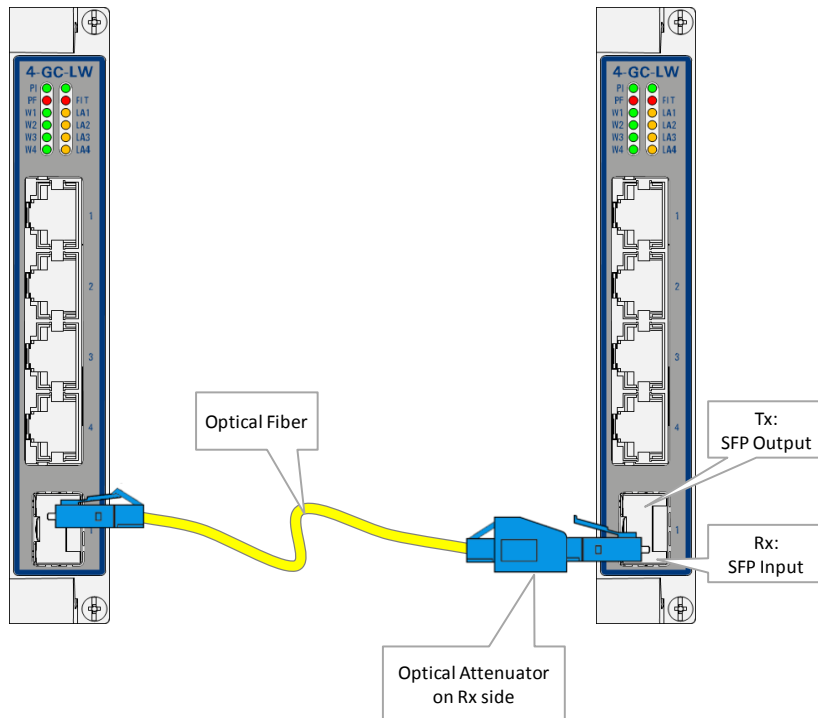

**Figure 3 SFP/XFP Cages**

### 1.5 Optical Attenuator

The input power at the receiver is not allowed to exceed the maximum input power. If it does exceed, replace the TRM of the transmitting node with a TRM with less output power or install an optical attenuator to avoid receiver overload. The value of this attenuator must be at least the difference between the received power and the maximum input power.

The figure below shows a male-female attenuator, which can be directly plugged onto the TRM connector. It is recommended to install the attenuator on the Rx side (to minimize the reflected light into the transmitter).



**Figure 4 Optical Attenuator on Rx Side**

## 2. SFP MODULES

**Table 2 Optical SFP Modules on IFMs**

IFM	Speed (Mbps)	SFP Type	Order Number	Fiber (*1) (Minimum Modal Bandwidth@ λ)	Typical Distance (km/miles)	λ (nm)	Max. Allowed Dispersion (ps/nm)	Pout (dbm)		Pin (dbm)	
								Min	Max	Min	Max
4-GC-LW 4-GCB-LW 4-GO-LW 9-L3A-L	1000	1000BASE-SX	942 245-017	MM 62.5 (160 MHz.km) MM 62.5 OM1 (200 MHz.km) MM 50 (400 MHz.km) MM 50 OM2 (500 MHz.km) MM 50 OM3 (2000 MHz.km)	0.220/0.136 0.275/0.170 0.500/0.310 0.550/0.341 1.000/0.621	850	NA	-9.5	0	-17	0
		1000BASE-LX	942 245-018	MM 62.5 (500 MHz.km) MM 50 (400 MHz.km) MM 50 (500 MHz.km) G.652	0.550/0.341 0.550/0.341 0.550/0.341 10/6.2	1310	53	-9.5	-3	-19	-3
		1000BASE-EX	942 245-019	G.652	40/24.9	1310	130	-3.0	2	-23	-3
		1000BASE-ZX	942 245-020	G.652/G.653/G.655	70/43.5	1550	1485	0	5	-22	-3
		1000BASE-OX	942 245-021	G.653/G.655	100/62.1	1550	1600	-2	3	-28	-8
		1000BASE-EZ	942 245-022	G.653/G.655	120/74.6	1550	1485	0	5	-32	-8
		1000Base-BX-20-U (*U)	942 245-023	G.652	20/12.4	1310 (Tx) / 1550 (Rx)	400	-8	0	-22	-3
		1000Base-BX-20-D (*D)	942 245-024	G.652	20/12.4	1550 (Tx) / 1310 (Rx)	400	-8	0	-22	-3
		1000Base-BX-80-U (*U)	942 245-025	G.652/G.653/G.655	80/49.7	1490 (Tx) / 1590 (Rx)	1600	-2	4	-26	0
		1000Base-BX-80-D (*D)	942 245-026	G.652/G.653/G.655	80/49.7	1590 (Tx) / 1490 (Rx)	1600	-2	4	-26	0
		1000BASE-ZX CWDM (*2)	(*3)	G.652/G.653/G.655	70/43.5	See Table 6	1485	0	5	-23	-3
		1000BASE-EX CWDM (*2)	(*3)	G.652/G.653/G.655	40/24.9	See Table 6	1485	-5	0	-23	-3
		1000BASE-XR DWDM (*2)	942 250-0xx (*4)	G.652/G.653/G.655	120[170]/74.6[105.6] (*6)	See Table 7	3200 (*5)	3	7	-28	-9
		C37.94	2	C37.94	942 245-028	MM	2/1.2	850	NA	-19	-11
C37.94 S1	942 245-029			G.652/G.653/G.655	15/9.3	1310	NA	-15	-8	-34	-3

(\*1) : Preferred fiber type. If other than the mentioned fibers are used, dispersion effects can limit the distance. Due to cut-off wavelength it is possible G.655 will not work together with 1310 nm SFP.

(\*2) : These modules have a limited ambient temperature range of [-20...50°C/-4...122°F].

(\*3) : See Table 6 to find out which wavelengths are available.

(\*4) : 'xx' represents a number referring to a module depending on the wavelength. See Table 7 to find out which wavelengths are available.

(\*5) : include a 3dB dispersion penalty @ 3200 ps/nm.

(\*6) : Amplified links possible up to the distance between the brackets [ ] without dispersion compensation.

(\*U)/(\*D) : Bi-directional SFP = Bidi SFP → Always use (\*U)/(\*D) together over one optical link, e.g. (\*U) at one side of the optical link and (\*D) at the other side of the optical link.

**Table 3 Optical Smart SFP Modules on IFMs**

IFM	Speed (Mbps)	SFP Type	Order Number	Fiber (*1)	Typical Distance (km/miles)	$\lambda$ (nm)	Max. Allowed Dispersion (ps/nm)	Pout (dbm)		Pin (dbm)	
								Min	Max	Min	Max
4-GC-LW 4-GCB-LW 4-GO-LW	155.52 $\leftarrow \rightarrow$ 1000	TSOP: STM1 S1/OC3 I1 $\leftarrow \rightarrow$ 1000BASE	942 245-030	G.652	15/9.32	1310	96	-15	-7	-28	-8
	622.08 $\leftarrow \rightarrow$ 1000	TSOP: STM4 S1/OC12 I1 $\leftarrow \rightarrow$ 1000BASE	942 245-031	G.652	15/9.32	1310	74	-15	-7	-28	-8

NOTE: Smart SFPs need some extra configuration in HiProvision, see Ref. [8] in Table 1.  
 (\*1) : Preferred fiber type. If other than the mentioned fibers are used, dispersion effects can limit the distance.

**Table 4 Electrical SFP Modules on IFMs**

IFM	Speed (Mbps)	SFP Type	Order Number	Typical Distance (km/miles)
4-GC-LW 4-GCB-LW 4-GO-LW 9-L3A-L	1000	10/100/1000Base-T (via RJ-45)	942 245-027	0.1/0.62



### 3. XFP MODULES

Table 5 Optical XFP Modules

IFM	Speed (Gbps)	XFP Type	Order Number	Fiber (*1) (Minimum Modal Bandwidth@ λ)	Typical Distance (km/miles)	Typical λ (nm)	Max. Allowed Dispersion (ps/nm)	Pout (dbm)		Pin (dbm)	
								Min	Max	Min	Max
1-10G-LW 9-L3A-L	10	10GBASE-SR/-SW	942 246-001	MM 62.5 (160 MHz.km) MM 62.5 OM1 (200 MHz.km) MM 50 (400 MHz.km) MM 50 OM2 (500 MHz.km) MM 50 OM3 (2000 MHz.km)	0.026/0.016 0.033/0.020 0.066/0.041 0.082/0.051 0.300/0.186	850	NA	-7.3	-1	-9.9	-1
		10GBASE-LR/-LW	942 246-002	G.652	10/6.2	1310	NA	-8.2	-0.5	-14.4	0.5
		10GBASE-ER/-EW	942 246-003	G.652/G.653/G.655	40/24.8	1550	800	-1	2	-16	-1
		10GBASE-ZR/-ZW	942 246-004	G.652/G.653/G.655	80/49.7	1550	1600	0	4	-24	-7
		10GBASE-XR/XW (*2)	942 246-005	G.652/G.653/G.655	70[120]/43.5[74.6] (*4)	1550	2400	0	4	-22	-9
		10GBASE-ER/-EW DWDM (*2)	942 247-0xx (*3)	G.652/G.653/G.655	40/24.8	See Table 7	800	-3	3	-16	-1
		10GBASE-ZR/-ZW DWDM (*2)	942 248-0xx (*3)	G.652/G.653/G.655	70/43.5	See Table 7	1450	-1	3	-23	-7
<p>(*1) : Preferred fiber type. If other than the mentioned fibers are used, dispersion effects can limit the distance.            (*2) : These modules have a limited ambient temperature range of [-20...50°C/-4..122°F].            (*3) : 'xx' represents a number referring to a module depending on the wavelength. See Table 7 to find out which wavelengths are available.            (*4) : Amplified links possible up to the distance between the brackets [ ] without dispersion compensation.            (XFP Type) : -&lt;x&gt;R/-&lt;x&gt;W (e.g. -SR/-SW) = 'R' represents the LAN PHY mode whereas 'W' represents the WAN PHY Mode. Each XFP supports both LAN PHY and WAN PHY mode, see also 1-10G-LW manual Ref. [4] in Table 1 for more information on LAN PHY/WAN PHY.</p>											

#### 4. CWDM MODULES FOR 1000 MBPS

Table 6 CWDM Modules for 1000 Mbps: Order Numbers

Wavelength $\lambda$ (nm)	SFP	
	1000BASE-EX CWDM (40km)	1000BASE-ZX CWDM (80km)
1471	942 245-001	942 245-009
1491	942 245-002	942 245-010
1511	942 245-003	942 245-011
1531	942 245-004	942 245-012
1551	942 245-005	942 245-013
1571	942 245-006	942 245-014
1591	942 245-007	942 245-015
1611	942 245-008	942 245-016

## 5. DWDM ITU CHANNELS FOR OPTICAL MODULES

**Table 7 DWDM ITU Channels for 1 or 10 Gbps , Frequency, Wavelengths**

xx ITU Channel	Frequency (THz)	Wavelength $\lambda$ (nm)	XFP PTN-XFP-DWDM-ER-xx 10GBASE-ER/EW DWDM 942 247-0xx	XFP PTN-XFP-DWDM-ZR-xx 10GBASE-ZR/ZW DWDM 942 248-0xx	SFP PTN-SFP-DWDM-XR-xx 1000BASE-XR DWDM 942 250-0xx
17	191.7	1563.86	Available	Available	Available
18	191.8	1563.05	Available	Available	Available
19	191.9	1562.23	Available	Available	Available
20	192.0	1561.42	Available	Available	Available
21	192.1	1560.61	Available	Available	Available
22	192.2	1559.79	Available	Available	Available
23	192.3	1558.98	Available	Available	Available
24	192.4	1558.17	Available	Available	Available
25	192.5	1557.36	Available	Available	Available
26	192.6	1556.56	Available	Available	Available
27	192.7	1555.75	Available	Available	Available
28	192.8	1554.94	Available	Available	Available
29	192.9	1554.13	Available	Available	Available
30	193.0	1553.33	Available	Available	Available
31	193.1	1552.52	Available	Available	Available
32	193.2	1551.72	Available	Available	Available
33	193.3	1550.92	Available	Available	Available
34	193.4	1550.12	Available	Available	Available
35	193.5	1549.32	Available	Available	Available
36	193.6	1548.52	Available	Available	Available
37	193.7	1547.72	Available	Available	Available
38	193.8	1546.92	Available	Available	Available
39	193.9	1546.12	Available	Available	Available
40	194.0	1545.32	Available	Available	Available
41	194.1	1544.53	Available	Available	Available
42	194.2	1543.73	Available	Available	Available
43	194.3	1542.94	Available	Available	Available
44	194.4	1542.14	Available	Available	Available
45	194.5	1541.35	Available	Available	Available
46	194.6	1540.56	Available	Available	Available
47	194.7	1539.77	Available	Available	Available
48	194.8	1538.98	Available	Available	Available
49	194.9	1538.19	Available	Available	Available
50	195.0	1537.40	Available	Available	Available
51	195.1	1536.61	Available	Available	Available
52	195.2	1535.82	Available	Available	Available
53	195.3	1535.04	Available	Available	Available
54	195.4	1534.25	Available	Available	Available
55	195.5	1533.47	Available	Available	Available
56	195.6	1532.68	Available	Available	Available
57	195.7	1531.90	Available	Available	Available
58	195.8	1531.12	Available	Available	Available
59	195.9	1530.33	Available	Available	Available
60	196.0	1529.55	Available	Available	Available
61	196.1	1528.77	Available	Available	Available

## 6. ABBREVIATIONS

<b>BiDi</b>	Bi-Directional SFP
<b>CWDM</b>	Coarse Wave Division Multiplexing
<b>DWDM</b>	Dense Wave Division Multiplexing
<b>Gbps</b>	Gigabits per Second
<b>IFM</b>	Interface Module
<b>LC</b>	Lucent Connector / Local Connector Snap
<b>Mbps</b>	Megabits per Second
<b>MM</b>	Multimode
<b>MPLS-TP</b>	Multiprotocol Label Switching – Transport Profile
<b>PC</b>	Physical Contact
<b>PTN</b>	Packet Transport Network
<b>Rx</b>	Receive
<b>SFP</b>	Small Form factor Pluggable
<b>SM</b>	Single Mode
<b>TRM</b>	Transmit Receive Module
<b>TSoP</b>	Transparent Sonet/SDH over Packet
<b>Tx</b>	Transmit
<b>UPC</b>	Ultra Physical Contact
<b>XFP</b>	10G Small Form Factor Pluggable