



**HIRSCHMANN**

A **BELDEN** BRAND

# User Manual

## Installation

### Dragon PTN Interface Module

### PTN-2-C37.94 with E1/PTN-2-C37.94 with T1

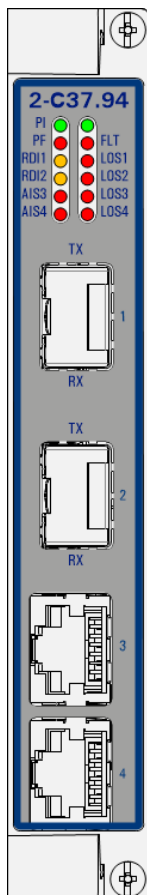

The naming of copyrighted trademarks in this manual, even when not specially indicated, should not be taken to mean that these names may be considered as free in the sense of the trademark and tradename protection law and hence that they may be freely used by anyone.

© 2018 Hirschmann Automation and Control GmbH

Manuals and software are protected by copyright. All rights reserved. The copying, reproduction, translation, conversion into any electronic medium or machine scannable form is not permitted, either in whole or in part. An exception is the preparation of a backup copy of the software for your own use.

The performance features described here are binding only if they have been expressly agreed when the contract was made. This document was produced by Hirschmann Automation and Control GmbH according to the best of the company's knowledge. Hirschmann reserves the right to change the contents of this document without prior notice. Hirschmann can give no guarantee in respect of the correctness or accuracy of the information in this document.

Hirschmann can accept no responsibility for damages, resulting from the use of the network components or the associated operating software. In addition, we refer to the conditions of use specified in the license contract.

You can get the latest version of this manual on the Internet at the Hirschmann product site ([www.hirschmann.com](http://www.hirschmann.com)).

Hirschmann Automation and Control GmbH  
Stuttgarter Str. 45-51  
72654 Neckartenzlingen  
Germany

## Contents

|            |  |           |
|------------|--|-----------|
| <b>1.</b>  | <b>INTRODUCTION .....</b>                                  | <b>6</b>  |
| <b>1.1</b> | <b>General.....</b>  | <b>6</b>  |
| <b>1.2</b> | <b>Manual References .....</b>                             | <b>7</b>  |
| <b>2.</b>  | <b>MODULE DESCRIPTION .....</b>                            | <b>8</b>  |
| <b>2.1</b> | <b>Front Panel .....</b>                                   | <b>8</b>  |
| 2.1.1      | Handle.....  | 8         |
| 2.1.2      | LEDs.....  | 8         |
| 2.1.3      | C37.94 SFP Port (Fiber) .....                              | 10        |
| 2.1.4      | E1/T1 RJ-45 Ports (Copper) and Cables .....                | 10        |
| <b>2.2</b> | <b>Functional Operation .....</b>                          | <b>10</b> |
| 2.2.1      | General .....  | 10        |
| 2.2.2      | E1 Framing .....   | 11        |
| 2.2.3      | T1 Framing .....   | 12        |
| 2.2.4      | C37.94 Framing.....  | 12        |
| 2.2.5      | AMI, HDB3 and B8ZS Coding .....                            | 13        |
| 2.2.6      | CES: SAToP .....   | 14        |
| 2.2.7      | CES: CESoPSN .....   | 15        |
| 2.2.8      | Start Sending Data .....                                   | 19        |
| 2.2.9      | SAToP Compared With CESoPSN .....                          | 19        |
| 2.2.10     | Hitless Switching.....                                     | 19        |
| 2.2.11     | Single Path .....  | 20        |
| 2.2.12     | Delay Comparison in CES (Features) .....                   | 22        |
| 2.2.13     | I/O with the Central Switching Module (=CSM) .....         | 22        |
| 2.2.14     | Synchronization / Clock Distribution / Network Timing..... | 22        |
| 2.2.15     | Short Haul/Long Haul on E1/T1 Ports.....                   | 25        |
| 2.2.16     | Test and Loopback Selftests .....                          | 25        |
| <b>2.3</b> | <b>Onboard Interfaces .....</b>                            | <b>25</b> |
| 2.3.1      | Straps .....   | 26        |
| 2.3.2      | DIP Switches .....   | 26        |
| <b>3.</b>  | <b>TDM FRAMES/PACKET .....</b>                             | <b>26</b> |
| <b>3.1</b> | <b>General.....</b>  | <b>26</b> |
| <b>3.2</b> | <b>Bandwidth.....</b>                                      | <b>27</b> |
| <b>3.3</b> | <b>Delay .....</b>   | <b>27</b> |
| 3.3.1      | General .....  | 27        |
| 3.3.2      | Delay Parameters .....                                     | 28        |
| 3.3.3      | Estimated Delay Calculation and Formulas .....             | 29        |
| 3.3.4      | Estimated Delay Examples.....                              | 29        |
| 3.3.5      | Differential Delay.....                                    | 29        |
| <b>3.4</b> | <b>Tuning CES = Tuning TDM Frames/Packet.....</b>          | <b>30</b> |
| <b>4.</b>  | <b>COMPATIBILITY.....</b>                                  | <b>30</b> |
| <b>5.</b>  | <b>MODULE SPECIFICATIONS .....</b>                         | <b>31</b> |

|            |                                    |           |
|------------|------------------------------------|-----------|
| <b>5.1</b> | <b>General Specifications.....</b> | <b>31</b> |
| <b>5.2</b> | <b>Other Specifications.....</b>   | <b>31</b> |
| <b>5.3</b> | <b>Ordering Information.....</b>   | <b>31</b> |
| <b>6.</b>  | <b>ABBREVIATIONS .....</b>         | <b>31</b> |

### List of figures

|           |   |    |
|-----------|---|----|
| Figure 1  | Common Example with C37.94, E1, T1.....                                   | 7  |
| Figure 2  | Front Panel .....   | 8  |
| Figure 3  | C37.94 SFP Connector .....  | 10 |
| Figure 4  | E1/T1 RJ-45 Connector .....   | 10 |
| Figure 5  | Detailed Function C37.94/E1/T1 Example.....                               | 11 |
| Figure 6  | E1 Framing.....   | 12 |
| Figure 7  | T1 Framing.....   | 12 |
| Figure 8  | C37.94 Framing.....   | 13 |
| Figure 9  | HDB3 Encoding .....   | 13 |
| Figure 10 | T1: B8ZS Encoding .....   | 13 |
| Figure 11 | General SAToP Example .....   | 14 |
| Figure 12 | Detailed E1 SAToP Example.....  | 14 |
| Figure 13 | General CESoPSN via C37.94 Port Example.....                              | 15 |
| Figure 14 | Detailed C37.94 to C37.94 CESoPSN Example.....                            | 16 |
| Figure 15 | General CESoPSN via E1/T1 Port Example .....                              | 16 |
| Figure 16 | Detailed E1 CESoPSN Example .....   | 17 |
| Figure 17 | General CESoPSN via C37.94 to E1 Port Example .....                       | 18 |
| Figure 18 | Detailed C37.94 To E1 CESoPSN Example .....                               | 18 |
| Figure 19 | Hitless Switching.....  | 20 |
| Figure 20 | Single Path Enabled .....   | 21 |
| Figure 21 | Single Path Disabled .....  | 21 |
| Figure 22 | Clocking: Application D Slaves to Application A via Dragon PTN .....      | 23 |
| Figure 23 | Clocking: Both Application A and D Slave to Dragon PTN Clock Master ..... | 23 |
| Figure 24 | 2-C37.94: Side View.....  | 25 |
| Figure 25 | Hardware Edition.....   | 26 |
| Figure 26 | E1/T1 Configuration .....   | 26 |
| Figure 27 | SAToP, CESoPSN Bandwidth.....   | 27 |
| Figure 28 | Delays .....  | 28 |
| Figure 29 | Differential Delay.....   | 30 |

## List of Tables

|   |    |
|---|----|
| Table 1 Manual References.....                                    | 7  |
| Table 2 LED Indications In Boot Operation .....                   | 9  |
| Table 3 LED Indications In Normal Operation .....                 | 9  |
| Table 4 E1/T1 RJ-45 Connector: Pin Assignments.....               | 10 |
| Table 5 Comparison: SAToP $\leftrightarrow$ CESoPSN .....         | 19 |
| Table 6 Difference Between Hitless and Protection Switching ..... | 20 |
| Table 7 Clocking Parameters on Port & Service Level.....          | 24 |
| Table 8 TDM Frames/Packet .....                                   | 27 |
| Table 9 Estimated Delay Formulas .....                            | 29 |
| Table 10 Estimated Delay ( $\mu$ s) Examples.....                 | 29 |
| Table 11 Other Specifications.....                                | 31 |

# 1. INTRODUCTION

## 1.1 General

This document is valid as of Dragon PTN Release 3.0DR.

E1 and T1 links are used worldwide to implement synchronous TDM links between two end points. These links typically transport voice and/or data using TDM. The application of E1 or T1 is country related. T1 is primarily used on the North American continent and Japan whereas E1 is used in most other areas. Both carriers differ with respect to the physical interface, the framing algorithm, signaling and network management.

An E1 service bundles together 32 TDM (Time Division Multiplex) channels whereas a T1 service bundles together 24 TDM channels. This results in an E1 service having a total bandwidth of 2.048 Mbps and a T1 service a total bandwidth of 1.544 Mbps.

C37.94 is a standard for transmitting N times 64 kbps on an optical fiber, where N=1,2,...12. It is a protocol used in the power industry between teleprotection and multiplexer equipment. Teleprotection makes sure that faulty parts within a power system will be disconnected very fast to prevent further damage within that power system. A C37.94 frame also has a bandwidth of 2.048 Mbps and all its information is also transported in 32 timeslots, just like E1. But C37.94 is a special kind of E1 framing. Within these 32 E1 timeslots, C37.94 has its own timeslot mapping and uses N (=1 to 12) timeslots for real data, see §2.2.4.

HiProvision (=Dragon PTN Management System) has two variants of this IFM (see also §2.3.2b):

- ▶ 2-C37.94-E1-L = 2-C37.94 IFM in E1 mode;
- ▶ 2-C37.94-T1-L = 2-C37.94 IFM in T1 mode;

This IFM converts the C37.94/E1/T1 framing from a C37.94/E1/T1 link into MPLS-TP packets over the Dragon PTN network, and vice versa. The destination IFM must also compensate for possible jitter and network delays to keep everything synchronized. A packetized TDM service is called a Circuit Emulation Service (=CES). A maximum of 16 CESs can be configured per 2-C37.94 module.

2-C37.94 refers to '2 C37.94 ports and 2 E1/T1 ports'. This IFM can be used in any IFM slot of any node. An IFM slot overview can be found in Ref. [3] in Table 1.

The main supported features are:

- ▶ Packetizing of E1/T1 Framing
- ▶ LAN function
- ▶ Services
  - ▶ SAToP (=Structured Agnostic TDM over Packet) → all channels transparently;
  - ▶ CESoPSN (=CES over Packet Switched Network) → customized channel transport;
  - ▶ Hitless Switching / Single Path;
- ▶ Synchronization
  - ▶ SyncE;

A common example with C37.94, E1 and T1 can be found in the figure below:

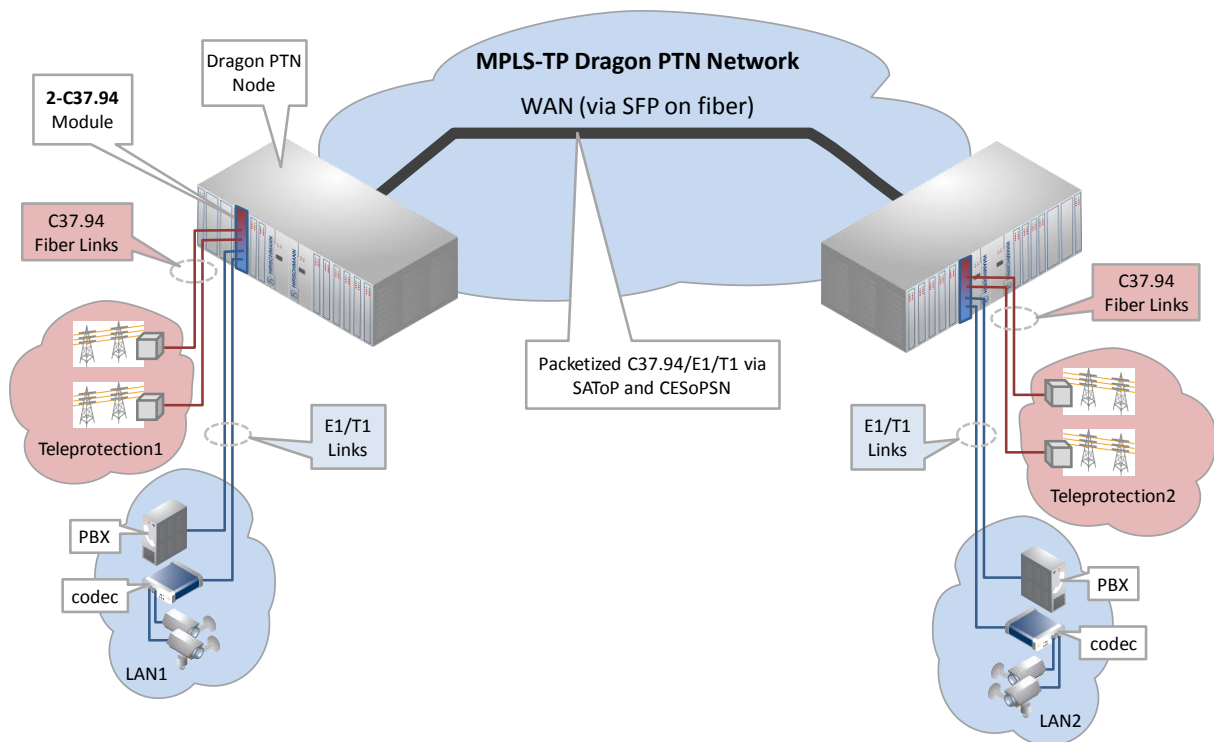

**Figure 1 Common Example with C37.94, E1, T1**

## 1.2 Manual References

Table 1 is an overview of the manuals referred to in this manual. ‘&’ refers to the language code, ‘\*’ refers to the manual issue. All these manuals can be found in the HiProvision (=Dragon PTN Management System) Help function.

**Table 1 Manual References**

| Ref. | Number         | Title  |
|------|----------------|--|
| [1]  | DRA-DRM821-&-* | Dragon PTN and HiProvision Operation                 |
| [2]  | DRA-DRM801-&-* | Dragon PTN Installation and Operation                |
| [3]  | DRB-DRM802-&-* | Dragon PTN Nodes: PTN2210, PTN2209, PTN2206, PTN1104 |
| [4]  | DRD-DRM803-&-* | Dragon PTN Switching Module: PTN-CSM310-A            |
| [5]  | DRE-DRM805-&-* | Dragon PTN Interface Module: PTN-4-E1-L/PTN-4-T1-L   |
| [6]  | DRF-DRM811-&-* | Dragon PTN TRMs (Transmit Receive Modules: SFP, XFP) |
| [7]  | DRA-DRM810-&-* | Dragon PTN General Specifications                    |
| [8]  | DRE-DRM818-&-* | Dragon PTN Switching Module: PTN-16-E1-L/PTN-16-T1-L |

## 2. MODULE DESCRIPTION

### 2.1 Front Panel

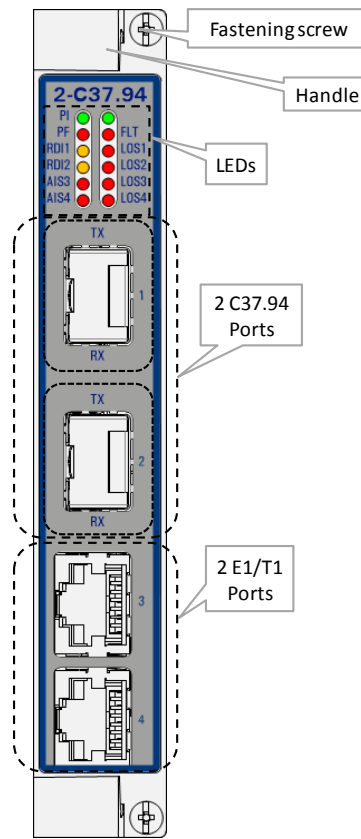

Figure 2 Front Panel

#### 2.1.1 Handle

##### a. Insert the Module into the Node

Take the front panel handles to insert or slide the module into the Dragon PTN node. Push the module thoroughly into the node's backplane. Next, tighten the two fastening screws in the front panel corners.

##### b. Remove the Module from the Node

Untighten the two fastening screws in the front panel corners. Take the front panel handles to pull out and finally remove the module from the Dragon PTN node.

#### 2.1.2 LEDs

The meaning of the LEDs depends on the mode of operation (= boot or normal) in which the 2-C37.94 module currently is running. After plugging in the module or rebooting it, the module turns into the boot operation, see Table 2. After the module has gone through all the cycles in the table below (=rebooted successfully), the module turns into the normal operation, see LEDs in Table 3.



**Table 2 LED Indications In Boot Operation**

| Cycle | PI | PF  | FLT           | Spare LED | RDI[1,2] | AIS[3,4] | LOS[1..4] |
|-------|----|-----|---------------|-----------|----------|----------|-----------|
| 1     | x  | --- | Slow blinking | ---       | ---      | ---      | ---       |
| 2     | x  | --- | Fast blinking | ---       | ---      | ---      | ---       |
| 3     | x  | --- | ---           | ---       | ---      | ---      | ---       |
| 4     | x  | --- | x             | ---       | x        | x        | x         |

x : LED is lit  
 --- : LED is not lit  
 The sub cycle times may vary.  
 The entire boot cycle time [1→4] takes approximately 2 minutes.

**Table 3 LED Indications In Normal Operation**

| LED  | Color            | Status  |
|--|------------------|---|
| PI (=Power Input)                                    | Not lit, dark    | +12V power input to the board not OK  |
|  | Green            | +12V power input to the board OK  |
| PF (=Power Failure)                                  | Not lit, dark    | power generation on the board itself is OK  |
|  | Red              | power generation on the board itself is erroneous   |
| FLT (=FauLT)   | Not lit, dark    | no other fault or error situation, different from PF, is active on the module   |
|  | Red              | a fault or error situation, different from PF, is active on the module  |
| (empty)  | Not lit, Green   | spare   |
| RDI<port n°><br>(=Remote Defect Indication)          | Not lit, dark    | - no service on this port<br>- service on this port: no alarms detected on backplane (=network) side, everything fine |
|  | Orange, lit      | service on this port: no network traffic or RDI detected on backplane (=network) side                                 |
|  | Orange, blinking | other errors different from RDI detected on backplane (=network) side   |
| AIS<port n°><br>(=Alarm Indication Signal)           | Not lit, dark    | - no service on this port<br>- service on this port: no alarms detected on backplane (=network) side, everything fine |
|  | Red, lit         | service on this port: no network traffic or TX AIS detected on backplane (=network) side                              |
|  | Red, blinking    | other errors different from TX AIS detected on backplane (=network) side  |
| LOS<port 1-2°><br>(C37.94 ports)<br>(Loss of Signal) | Not lit, dark    | - no service on this port<br>- service on this port: local C37.94 traffic on this front port is OK                    |
|  | Red, lit         | service on this port: LOF on this front port  |
|  | Red, blinking    | other errors different from LOF received on this front port   |
| LOS<port 3-4°><br>(E1/T1 ports)<br>(Loss of Signal)  | Not lit, dark    | - no service on this port<br>- service on this port: local E1/T1 traffic on this front port is OK                     |
|  | Red, lit         | service on this port: local E1/T1 signal is lost on this front port   |
|  | Red, blinking    | AIS, LOF or RAI received on this front port   |

### 2.1.3 C37.94 SFP Port (Fiber)

The 2-C37.94 module provides two SFP ports for long distance communication over optical fiber. The SFPs that can be used for this port can be found in Ref. [6] in Table 1.

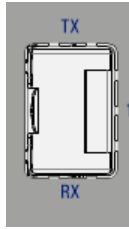

Figure 3 C37.94 SFP Connector

### 2.1.4 E1/T1 RJ-45 Ports (Copper) and Cables

The 2-C37.94 module provides two ports and each port connector has eight pins. Each port provides one tip/ring pair. See the table and figure below for an overview and description. Both the ports act as E1 or T1 port. This behavior can be configured via a DIP switch, see §2.3.2b. The cables below can be ordered to connect these ports.

- ▶ E1 cable (120 Ω): ordering number 942 256-201;
- ▶ T1 cable (100 Ω): ordering number 942 256-200;

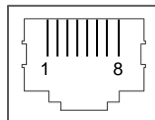

Figure 4 E1/T1 RJ-45 Connector

Table 4 E1/T1 RJ-45 Connector: Pin Assignments

| Pin Number | Description        | Cable Wire Colors |
|------------|--------------------|-------------------|
| 1          | Rx (Receive) RING  | OG                |
| 2          | Rx (Receive) TIP   | WH/OG             |
| 3          | Not connected      | -                 |
| 4          | Tx (Transmit) RING | BU                |
| 5          | Tx (Transmit) TIP  | WH/BU             |
| 6, 7, 8    | Not connected      | -                 |

## 2.2 Functional Operation

### 2.2.1 General

A teleprotection network (e.g. Teleprotection1) can be connected to the MPLS-TP Dragon PTN network via one of the two C37.94 interface ports. An external LAN (e.g. LAN1) can be connected to the MPLS-TP Dragon PTN network via one of the two E1/T1 interface ports. The 2-C37.94 module can interface with 2 C37.94 and/or 2 E1/T1 lines. In Figure 1, a common functional setup is shown.

In Figure 5 below, a more detailed functional setup is shown. A LAN1 network interfaces the Dragon PTN node via the E1/T1 ports on the 2-C37.94 module. The 2-C37.94 converts this traffic into Ethernet traffic on the backplane. The Central Switching Module (=CSM310-A) converts this Ethernet traffic into packetized E1/T1 MPLS-TP and transmits it via an Ethernet IFM (e.g. 4-GC-LW) onto the Dragon PTN MPLS-TP network. The packetizing of C37.94/E1/T1 occurs via CES: SAToP (see §2.2.6) or CES: CESoPSN (see §2.2.7) technique.

The CES is normally configured between two ports of the same type (between two C37.94 ports, two E1 or two T1 ports). Via the CES: CESoPSN, it is possible to configure a service between a C37.94 and an E1 or T1 port. In this way, it is possible to transport a C37.94 link further on over an SDH cloud or network, see §2.2.7 for some examples.

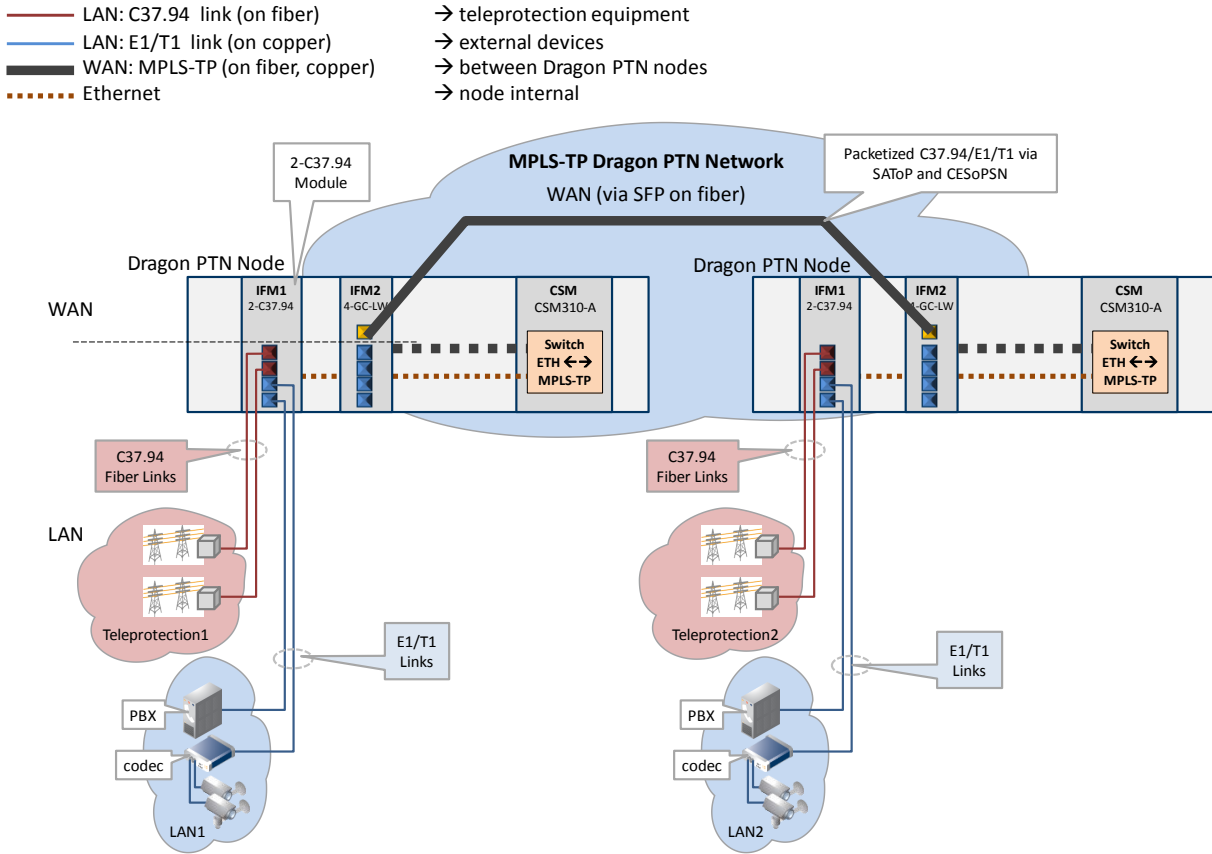
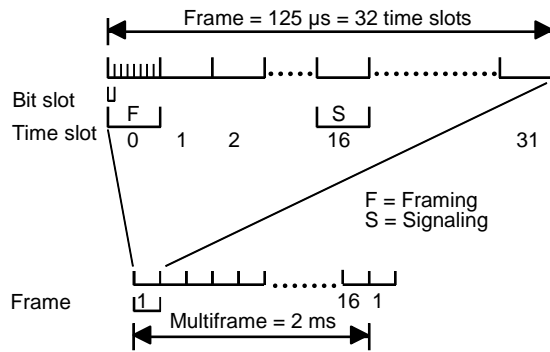

Figure 5 Detailed Function C37.94/E1/T1 Example

2.2.2 E1 Framing

E1 is a 2.048 Mbps bi-directional (full duplex) link through which the data is transported in a digital way in frames. One frame consists of 32 time slots (Figure 6). Timeslot 0 is used for framing and synchronization, and time slot 16 for signaling. The bandwidth of one time slot is 64 kbps (=8 bits/125 μs). One frame thus consists of 32\*8 = 256 bits and lasts 125 μs. Typically 16 frames are packed together in one multiframe.

NOTE: Multiframe = future support;

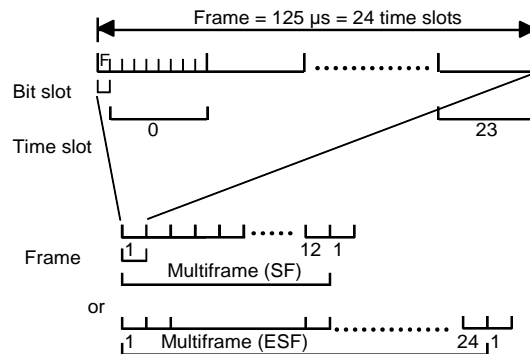

**Figure 6 E1 Framing**

### 2.2.3 T1 Framing

T1 is a 1.544 Mbps bi-directional (full duplex) link through which the data is transported in a digital way in frames. One frame consists of 24 time slots + 1 bit (Figure 7). The extra bit is used for framing. The bandwidth of one time slot is 64 kbps (8 bits). One frame thus consists of  $(24 \times 8) + 1 = 193$  bits and lasts 125 μs. Depending of the framing algorithm applied either 12 or 24 frames are packed together in one multiframe. Signaling bits are transported in the Least Significant Bit of the time slots in each multiframe agreed upon (in-band).

**NOTE:** Multiframe = (E)SF (=Extended) Super Frame) = future support;



**Figure 7 T1 Framing**

### 2.2.4 C37.94 Framing

A C37.94 optical link is a 2.048 Mbps bi-directional (full duplex) link through which the data is transported in a digital way in frames. One frame consists of a Header (=H), Overhead (=OH) and Timeslots (=T) including Channel Data, see figure below. The Header is used for framing and synchronization. The Overhead includes the number (=N) that indicates the amount of transported data channels ( $N = 1, 2, \dots, 12$ ). Each data channel bit in the timeslots is transmitted twice. It means that each time slot comprises  $8 \times 2 = 16$  bits. Unused timeslots are filled with ones. The bandwidth of one timeslot is 64 kbps (=8 bits/125 μs).

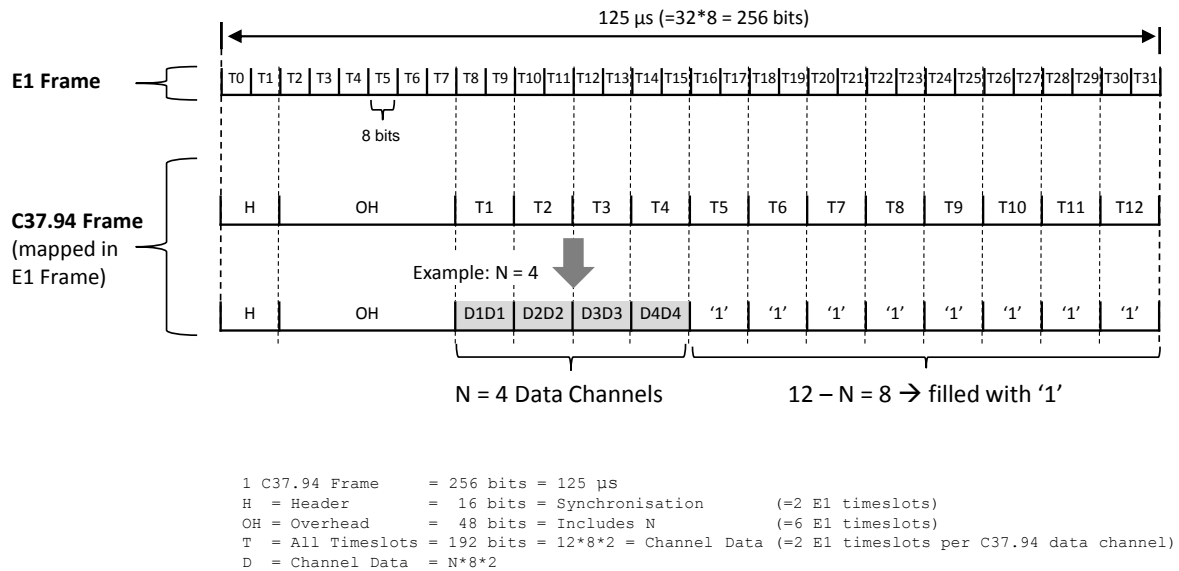

**Figure 8 C37.94 Framing**

### 2.2.5 AMI, HDB3 and B8ZS Coding

AMI, HDB3 and B8ZS are different types of line coding. HDB3 is used in E1 whereas B8ZS is used in T1 communications systems. The 2-C37.94 module supports HDB3 for E1 and B8ZS for T1. HDB3 and B8ZS is an enhancement of AMI. For this reason, AMI is mentioned here as well.

**NOTE:** C37.94 is pure optical. As a result, line coding for C37.94 is not relevant;

As the E1/T1 link has no separate clock transmission, the receiver will derive the clock from the incoming data stream. A minimum density of logical ones is required in order to guarantee a faultless clock recovery. This is achieved basically by AMI which encodes the data stream with bipolar violations. A more enhanced and better encoding is HDB3 and B8ZS which enhance the AMI stream by replacing successive zeros:

- ▶ E1 → HDB3: replace four successive zeros with a fixed bit pattern '000V' or 'B00V';
- ▶ T1 → B8ZS: replace eight successive zeros with a fixed bit pattern '000VB0VB';

A 'B' and 'V' can either be '-' or '+'. Which pattern is used depends on the amount of '+' and '-' already received. The choice is such that the number of pluses (+) between two successive violations (V) is odd.



**Figure 9 HDB3 Encoding**



**Figure 10 T1: B8ZS Encoding**

## 2.2.6 CES: SAToP

SAToP is a point-to-point CES which transparently sends the entire input frame (C37.94, E1 or T1) from the source to the destination port over the MPLS-TP Dragon PTN network. Both ports must be located in different nodes and the ports must be of the same type. The entire frame = all data + synchronization + alignment timeslots = 12 timeslots for C37.94, 32 timeslots for E1 and 24 timeslots for T1. As a result, maximum one SAToP service can be configured per port.

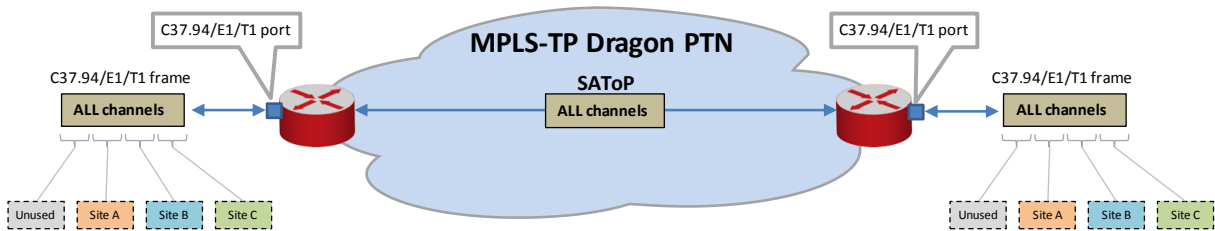

Figure 11 General SAToP Example

In the figure below, a more detailed E1 frame example has been worked out.

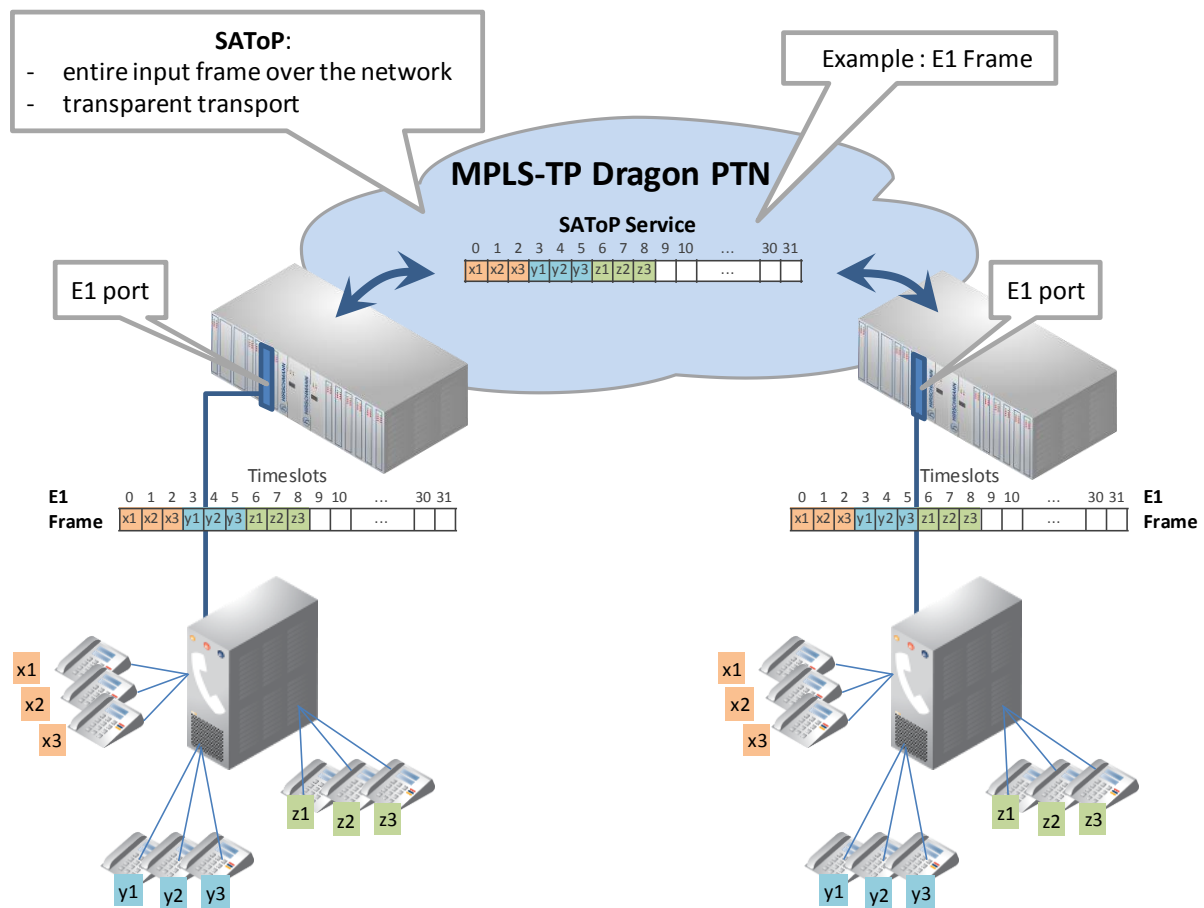

Figure 12 Detailed E1 SAToP Example

## 2.2.7 CES: CESoPSN

CESoPSN is a point-to-point CES which only sends a selection of channels or timeslots over the MPLS-TP Dragon PTN network. In HiProvision, the operator selects which timeslots of the input frame (C37.94, E1 or T1) must be transported. This customized transportation of timeslots through the network results in a more efficient bandwidth use.

The destination module will receive the transported channels from the Dragon PTN network, and regenerate all the other missing timeslots itself (empty or dummy timeslots, synchronization). As a result, the destination sends out the entire regenerated frame (C37.94, E1 or T1) on its port.

Each end-point or port (C37.94, E1 or T1) must be located in a different node.

CESoPSN services can be configured:

- ▶ Between two C37.94 ports, see below;
- ▶ Between two or more E1 ports, see below;
- ▶ Between two or more T1 ports, see below;
- ▶ Between a C37.94 and an E1 port, see below;
- ▶ Between a C37.94 and a T1 port, see below;

### a. Between Two C37.94 Ports

One CES per C37.94 port can be configured to transport timeslots between two C37.94 ports. In HiProvision, the operator configures just the amount of the timeslots (=n) to be transported. As a result, timeslots [1→n] will be transported over the Dragon PTN network. Make sure to keep your payload data or useful timeslots in the lowest timeslot numbers and the dummy or empty timeslots in the highest timeslot numbers.

For example, if the configured amount is five, then timeslot 1, 2, 3, 4, 5 will be transported. The remaining timeslots cannot be used anymore. On the destination side, the same timeslots will be used. See some examples in the figures below.

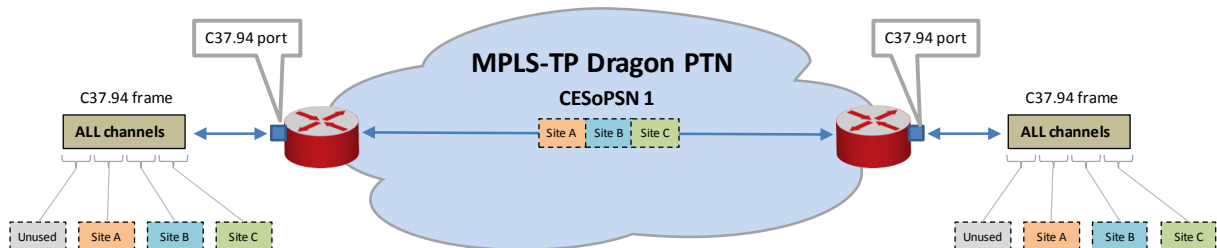

Figure 13 General CESoPSN via C37.94 Port Example

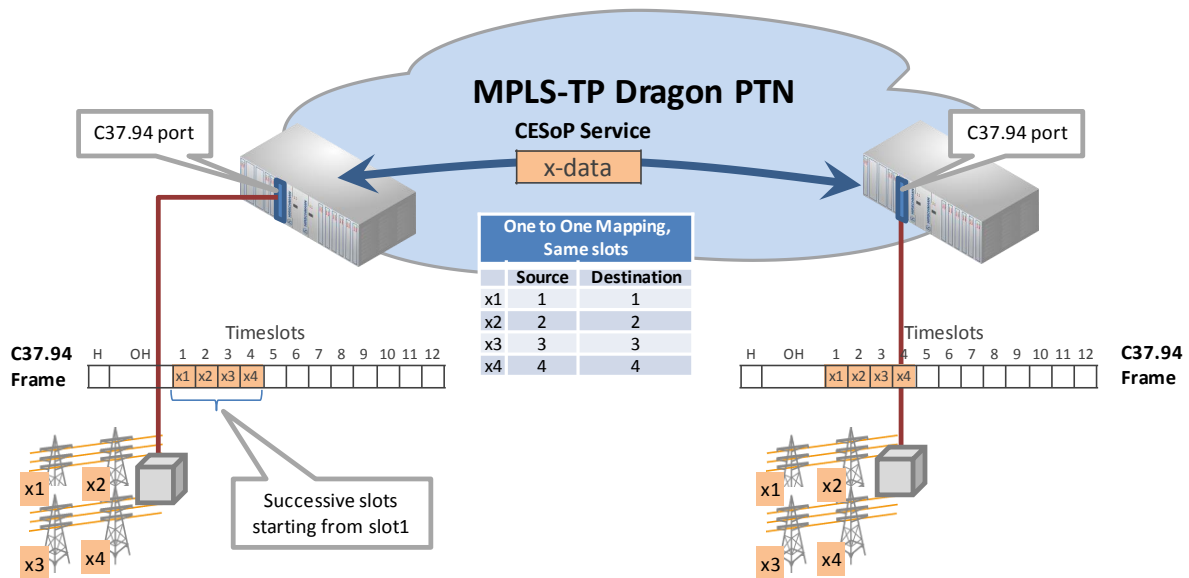

Figure 14 Detailed C37.94 to C37.94 CESoPSN Example

**b. Between Two or More E1 Ports**

Multiple CESs per port can be configured to transport an amount of timeslots between two or more E1 ports. In HiProvision, the operator selects the timeslots individually to be transported per CES. On both the source and destination side, the same amount of timeslots must be selected. The selected timeslots from the source side can be mapped onto the timeslots from the destination side.

The timeslot order does not change during the mapping. The first selected source timeslot will be mapped automatically onto the first selected destination timeslot etc....

See some examples in the figures below.

**NOTE:** In E1, timeslot 0 cannot be transported;

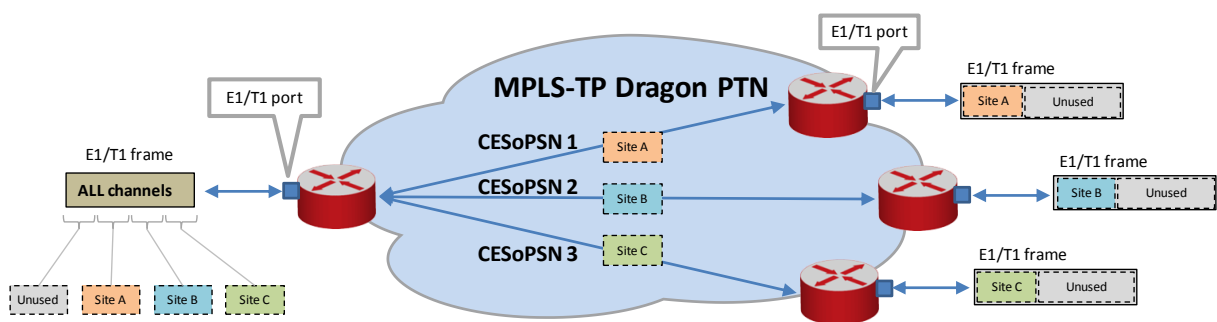
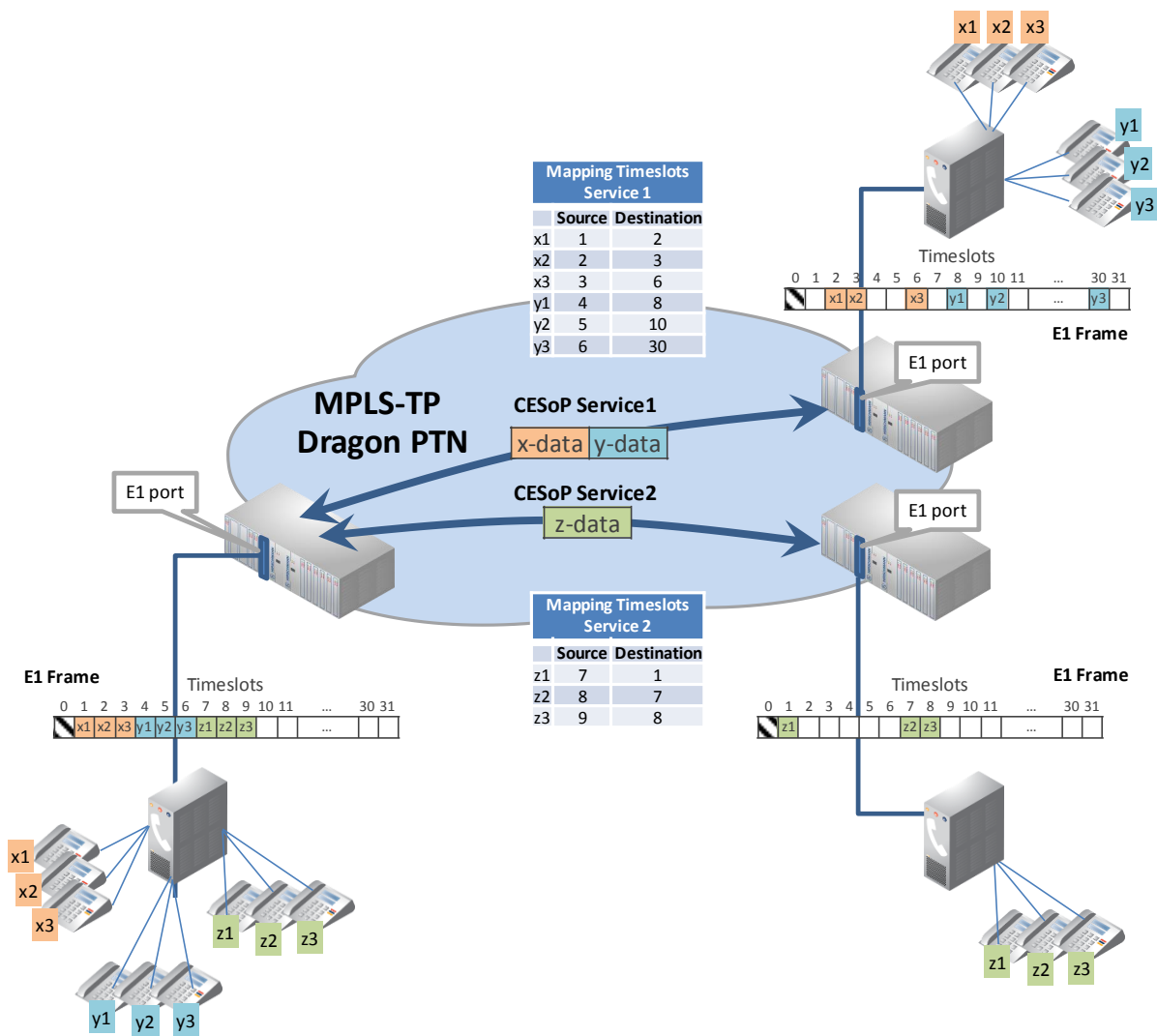

Figure 15 General CESoPSN via E1/T1 Port Example





**Figure 16 Detailed E1 CESoPSN Example**

**c. Between Two or More T1 Ports**

Similar to §2.2.7b.

**d. Between a C37.94 and an E1 Port**

One CES per C37.94 port can be configured to transport timeslots between a C37.94 port and an E1 port. In HiProvision, the operator configures just the amount of the timeslots (=n) to be transported. As a result, timeslots [1→n] will be transported over the Dragon PTN network. Make sure to keep your payload data or useful timeslots in the lowest timeslot numbers and the dummy or empty timeslots in the highest timeslot numbers.

For example, if the configured amount is five, then timeslot 1, 2, 3, 4, 5 will be transported. The remaining timeslots on the C37.94 port cannot be used anymore.

On the destination side or E1 port, the transported timeslots can be mapped onto other timeslots if desired. The remaining timeslots on the E1 port can still be used.

The timeslot order does not change during the mapping. The first selected source timeslot will be mapped automatically onto the first selected destination timeslot etc....

See some examples in the figures below.

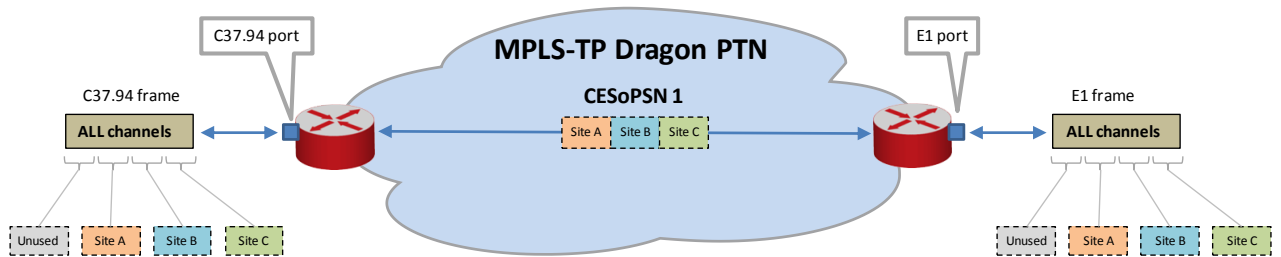

Figure 17 General CESoPSN via C37.94 to E1 Port Example

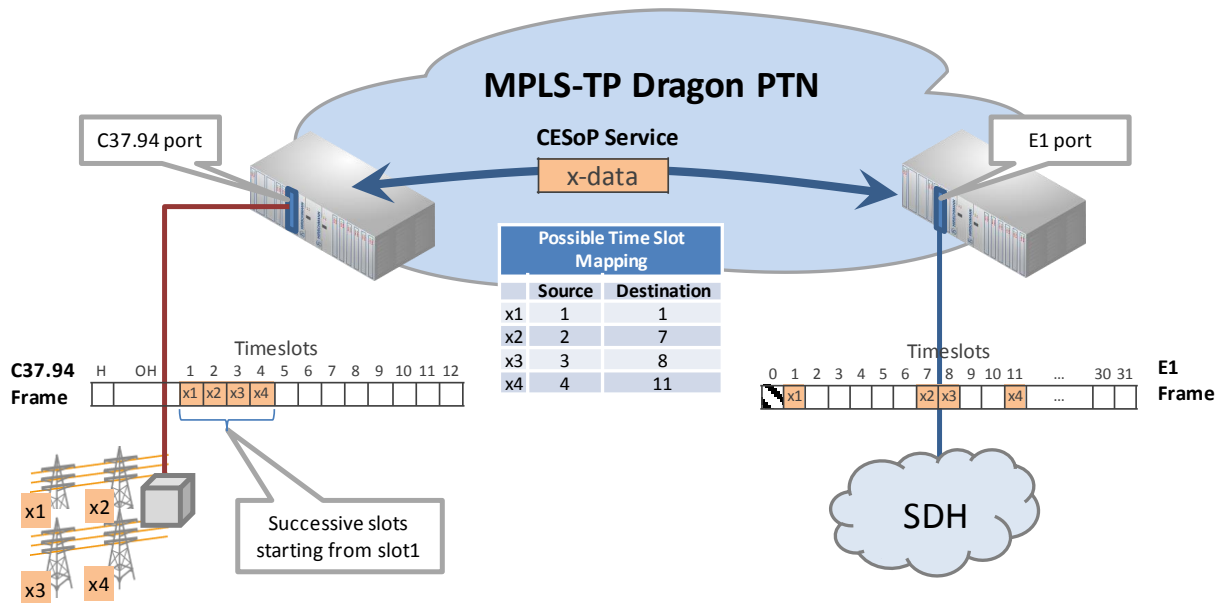

Figure 18 Detailed C37.94 To E1 CESoPSN Example

**e. Between a C37.94 and a T1 Port**

Similar to §2.2.7d.

## 2.2.8 Start Sending Data

It can be configured when a SAToP/CESoPSN service starts sending data. See 'send data' in the 'Dragon PTN and HiProvision Operation' Manual (=Ref. [1]) for more information.

## 2.2.9 SAToP Compared With CESoPSN

**Table 5 Comparison: SAToP ↔ CESoPSN**

|  | SAToP  | CESoPSN   |
|--|--|---|
| amount of services/port                      | 1  | 1 for C37.94;<br>16 for E1/T1; 16 is also the maximum per IFM;  |
| amount of used timeslots or channels/service | All timeslots. The entire input frame including all timeslots, header, synchronization.  | Configurable: amount on input = amount on output;<br>E1 timeslot 0 is never transported;  |
| timeslot mapping                             | The entire input frame is transported transparently through the network. As a result, 'timeslot x' on the input side will always be 'timeslot x' on the output side. | <p>Between two C37.94 ports:<br/>no timeslot mapping, 'timeslot x' on the input side = 'timeslot x' on the output side.</p> <p>Between two or more E1 ports:<br/>'timeslot x' on the input side can be mapped to 'timeslot y' on the output side;</p> <p>Between two or more T1 ports:<br/>'timeslot x' on the input side can be mapped to 'timeslot y' on the output side;</p> <p>Between C37.94 and E1 port:<br/>'timeslot x' on the input side can be mapped to 'timeslot y' on the output side;</p> <p>Per CESoPSN service, the timeslots on the input side must be part of the same port, the timeslots on the output side must be part of the same port.</p> <p>All the data channels on an input port can be mapped on different CESoPSN services, which can have different destination ports.</p> |

## 2.2.10 Hitless Switching

Hitless Switching is a feature within SAToP/CESoPSN that provides a safe C37.94/E1/T1 redundant connection where no data or synchronization is lost when switching from the active to the backup path or vice versa, e.g. because of cable break. The total delay over the network remains nearly constant during switch-over. Redundancy via Hitless Switching is obtained via completing the list below:

- ▶ creating two independent point-to-point tunnels without protection;
- ▶ setting the Hitless Switching on at service creation time in HiProvision.

**NOTE:** See Ref.[1] for the creation of tunnels and services;

On the source side, with Hitless Switching enabled, the IFM duplicates each packet on a second tunnel (e.g. Tunnel y, see figure below). Each packet also contains a 16 bit sequence number. Different tunnels mean different paths through the network, with each path its own delay. Different delays result in a slow and a fast path.

On the destination side, with Hitless Switching enabled, the 2-C37.94 IFM buffers the fastest path and forwards packets from the slowest path on the C37.94/E1/T1 link. Packets will be processed according a packet sequence number.

Hitless Switching is a redundant mechanism but differs from Protection Switching, see the table below for an overview. So if redundancy is needed in the service, either choose Hitless Switching or Protection Switching, mixing up both mechanisms is not allowed. Depending on the choice, settings must be done at tunnel creation time and/or service creation time.

When Hitless Switching has been enabled, the CES can only start up with two links up, coming out of a two-links-down situation (except when Single Path has been enabled, see §2.2.11).

See §2.2.11 for a delay comparison within CES depending on the enabled sub features, see also further on.

**Table 6 Difference Between Hitless and Protection Switching**

|                        | C37.94/E1/T1 Protection Switching | C37.94/E1/T1 Hitless Switching  |
|------------------------|-----------------------------------|---|
| required tunnel type   | 1 point-to-point tunnel           | 2 point-to-point tunnels  |
| tunnel protection type | 1:1;                              | none; the redundancy is created via two independent point-to-point tunnels. |
| service parameter      | Hitless Switching = disabled      | Hitless Switching = enabled   |
| at switch-over         | possible data loss                | no data or synchronization loss   |
| total delay            | less than hitless switching       | more than protection switching  |

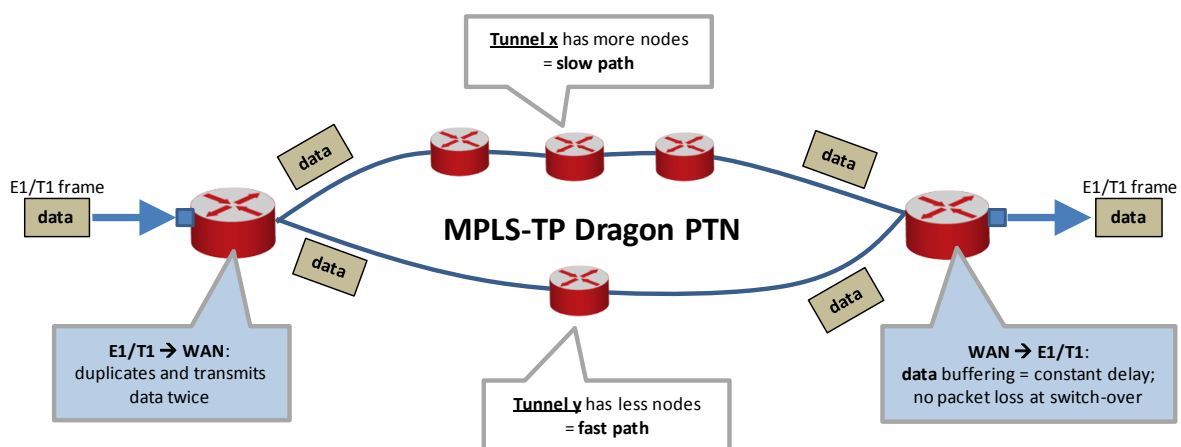

**Figure 19 Hitless Switching**

### 2.2.11 Single Path

The Single Path feature is a sub feature of Hitless Switching (see §2.2.10). It influences the start-up behavior of the Hitless Switching mechanism:

- ▶ enabled: The CES can already start up with only one link up, coming out of a two-links-down situation;

- ▶ if the fastest path came up first:
  - ▶ the CES starts up according to the fastest path;
  - ▶ possible CES interrupt or minor packet loss when the slowest path comes up later on;
- ▶ if the slowest path came up first:
  - ▶ the CES starts up according to the slowest path;
  - ▶ no CES interrupt or packet loss when the fastest path comes up later on;

See §2.2.12 for a delay comparison within CES depending on the enabled sub features, see also further on.

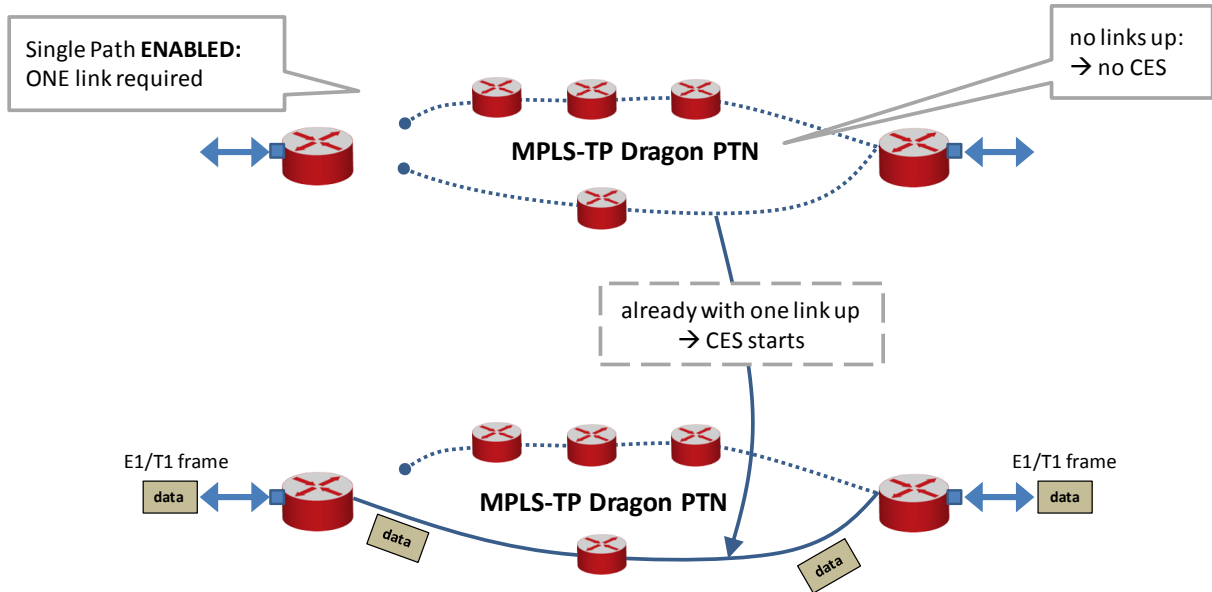

Figure 20 Single Path Enabled

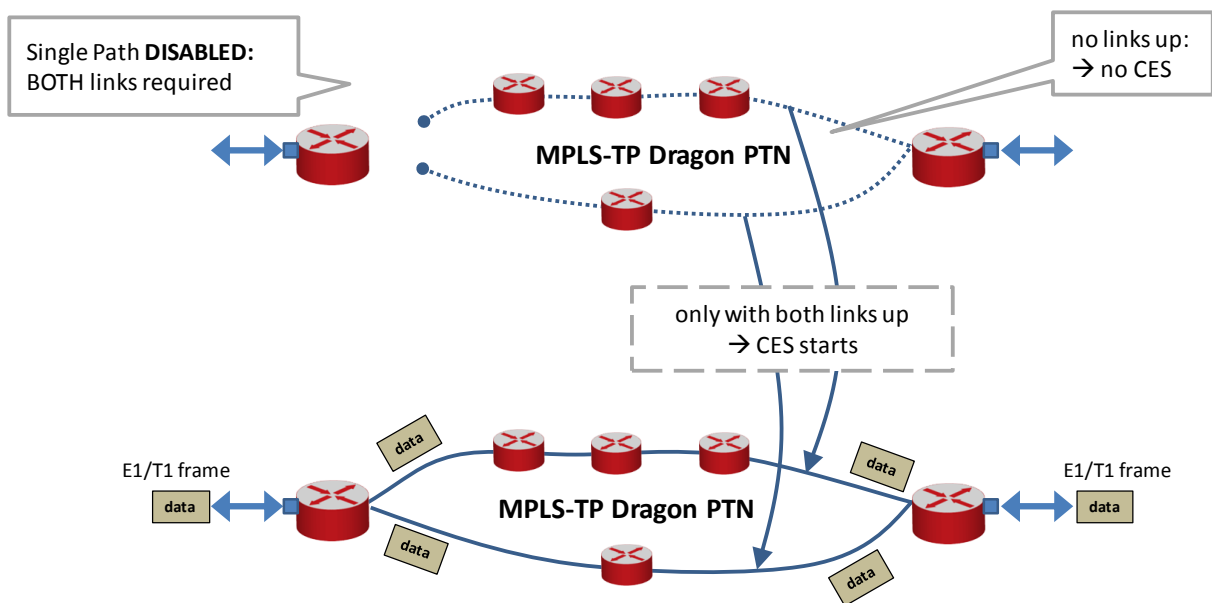

Figure 21 Single Path Disabled

### 2.2.12 Delay Comparison in CES (Features)

A CES with Hitless Switching has a higher delay than a CES without Hitless Switching.

### 2.2.13 I/O with the Central Switching Module (=CSM)

The 2-C37.94 module receives E1/T1/C37.94 traffic via its front panel ports and converts this into Ethernet traffic which is forwarded to the CSM via the backplane. The CSM does all the processing on this data (synchronization, CRC checks, conversions, switching...). The CSM converts this data into MPLS-TP packets and transmits it via a WAN port (on an IFM that supports WAN) onto the WAN. On the destination side, the same processing occurs in reverse order.

### 2.2.14 Synchronization / Clock Distribution / Network Timing

**CAUTION: Make sure to configure/verify the clocking parameters below.**

The Dragon PTN network provides a number of mechanisms to perform synchronization / clock distribution / network timing per CES. The CSM synchronizes all the included IFMs in the node.

The application endpoints in a 'Circuit Emulation: C37.94' service can communicate in a synchronized way. Which method can be used depends on:

- ▶ the 'Clock source' port setting of the two endpoints;
- ▶ the 'Differential Clocking' setting in this service;
- ▶ the Clock Source bundle ID in case of CESopSN;
- ▶ SyncE availability in the endpoint nodes;

The figures below show relevant end-to-end clocking configurations for this IFM. The PRC (=Primary Reference Clock) is a very stable high quality clock that can be used as a reference clock delivered via SyncE to the node:

- ▶ A, D = Application ports;
- ▶ B, C = IFM front ports;

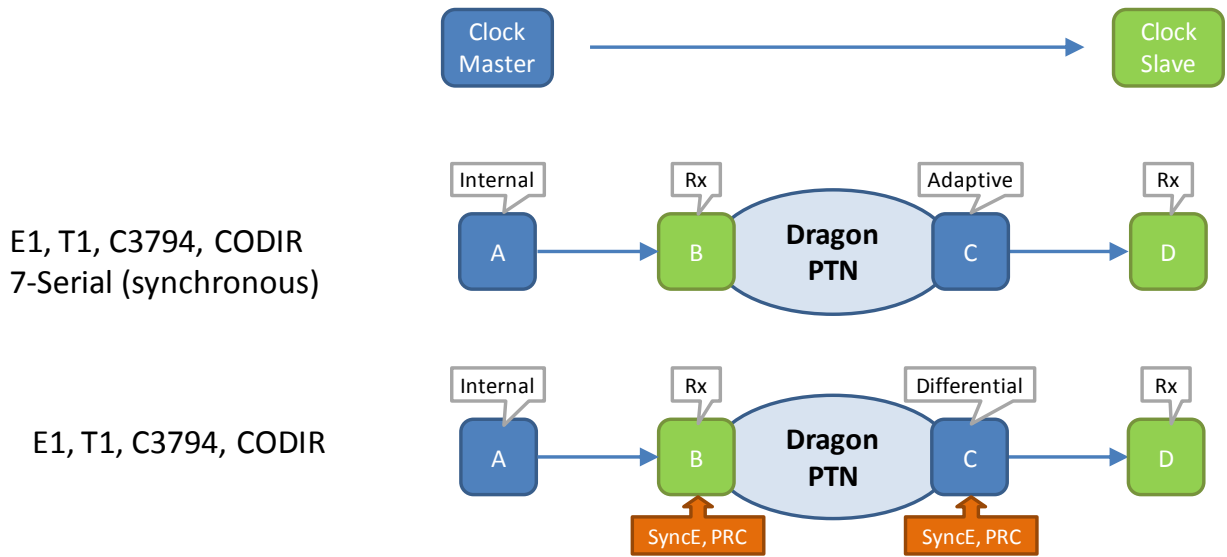

**Figure 22 Clocking: Application D Slaves to Application A via Dragon PTN**

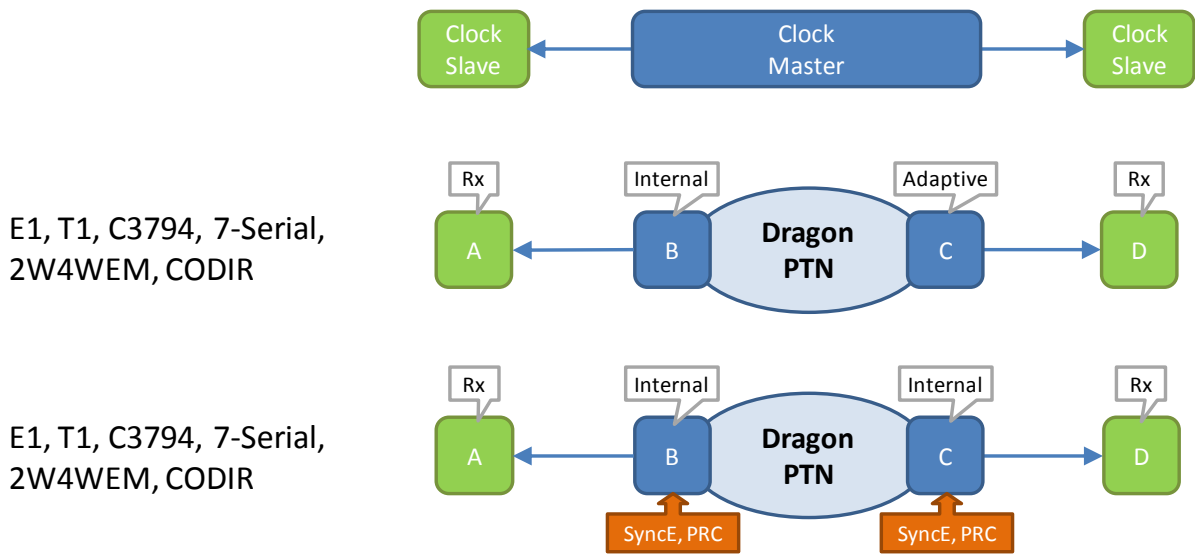

**Figure 23 Clocking: Both Application A and D Slave to Dragon PTN Clock Master**

**Table 7 Clocking Parameters on Port & Service Level**

| <b>Port A:<br/>Clock<br/>Source</b>  | <b>Port B:<br/>Clock<br/>Source</b> | <b>Service:<br/>Differential<br/>Clocking</b> | <b>Port C:<br/>Clock<br/>Source</b>    | <b>Port D:<br/>Clock<br/>Source</b> | <b>Description</b>  |
|--|-------------------------------------|---|--|-------------------------------------|---|
| <b>Application D slaves to application A via Dragon PTN</b>  |                                     |   |  |                                     |   |
| 'Internal Clock'   | 'Rx Clock'                          | Unchecked                                     | 'Adaptive/<br>Differential'            | 'Rx Clock'                          | <p>Node (B) recovers the clock from the incoming data stream from Application (A) and uses it to decode/encode the packet stream.</p> <p>Node (C) recovers the clock from the incoming packet stream from the network and uses it to encode/decode the data stream. Application (D) slaves its clock to this stream.</p>  |
| 'Internal Clock'   | 'Rx Clock'<br>+ SyncE               | Checked                                       | 'Adaptive/<br>Differential'<br>+ SyncE | 'Rx Clock'                          | <p>Node (B) recovers the clock from the incoming data stream from Application (A) and uses it to decode/encode the packet stream. Node (B) embeds extra RTP timing information in that packet stream when forwarding it on the Dragon PTN network.</p> <p>Node (C) generates the clock based on the PRC and the embedded RTP timing information in the incoming packet stream. The generated clock is used to encode/decode the data stream. Application (D) slaves its clock to this stream.</p> |
| <b>Both Applications A and D slave to Dragon PTN Clock Master</b>  |                                     |   |  |                                     |   |
| 'Rx Clock'   | 'Internal Clock'                    | Unchecked                                     | 'Adaptive/<br>Differential'            | 'Rx Clock'                          | <p>Node (B) transmits packets to node (C) based on an Internal Clock. This clock is delivered by the local oscillator on the IFM. Node (C) recovers the clock from the incoming packet stream from the network and uses it to encode/decode data streams.</p> <p>Both applications (A) and (D) slave their clock to the data streams delivered by node (B) and (C).</p>   |
| 'Rx Clock'   | 'Internal Clock'<br>+ SyncE         | Unchecked                                     | 'Internal Clock'<br>+ SyncE            | 'Rx Clock'                          | <p>Both nodes (B) and (C) encode/decode the data stream to/from the end applications based on the 'Internal Clock' on the IFM. This clock is delivered by the CSM and is based on a PRC delivered via SyncE.</p> <p>Both applications (A) and (D) slave their clock to the data streams delivered by node (B) and (C).</p>  |
| <b>E1/T1 port: CESoPSN Clock Source Bundle Id</b>  |                                     |   |  |                                     |   |
| <p><b>Fill out the 'Clock Source Bundle id':</b> Each E1/T1 CESoPSN service that is created in HiProvision will automatically get a 'bundle ID' assigned. The value of this 'Bundle ID' can be found in HiProvision → Network → Services → Monitoring Properties → Circuit Emulation. This value must be filled out in the 'CESoPSN Clock Source Bundle ID' port property to indicate to which CESoPSN service this port must slave its clock (=adaptive).</p> |                                     |   |  |                                     |   |

**NOTE:** SyncE: See the manuals in Ref.[1] and Ref.[4] for more detailed information;



### 2.2.15 Short Haul/Long Haul on E1/T1 Ports

Long E1/T1 links (>200m, Long Haul) have more signal attenuation than shorter links (<200m, Short Haul). As a result, the signal levels or sensitivity ('0' or '1') on the receiver side must be configured according to the used link: Long Haul or Short Haul.

In HiProvision, a Short Haul parameter can be checked for Short Haul links and unchecked (=default) for Long Haul links. This parameter can be set on port level in the IFM or at service creation.

**NOTE:** This setting is not relevant for the C37.94 ports;

### 2.2.16 Test and Loopback Selftests

Test and Loopback selftests can be performed in CESes, e.g. when configuring or troubleshooting a CES. Following two functions can be used in a programmed CES:

- ▶ Loopbacks: on backplane or front port, direction towards line (=application) or network can be configured;
- ▶ BERT: test traffic generation and verification via Bit Error Ratio Tester.

**CAUTION: enabling selftests disables or disturbs normal service traffic on a port!**

For more information and configuration settings, see 'Test and Loopback' in Ref.[1] in Table 1.

## 2.3 Onboard Interfaces

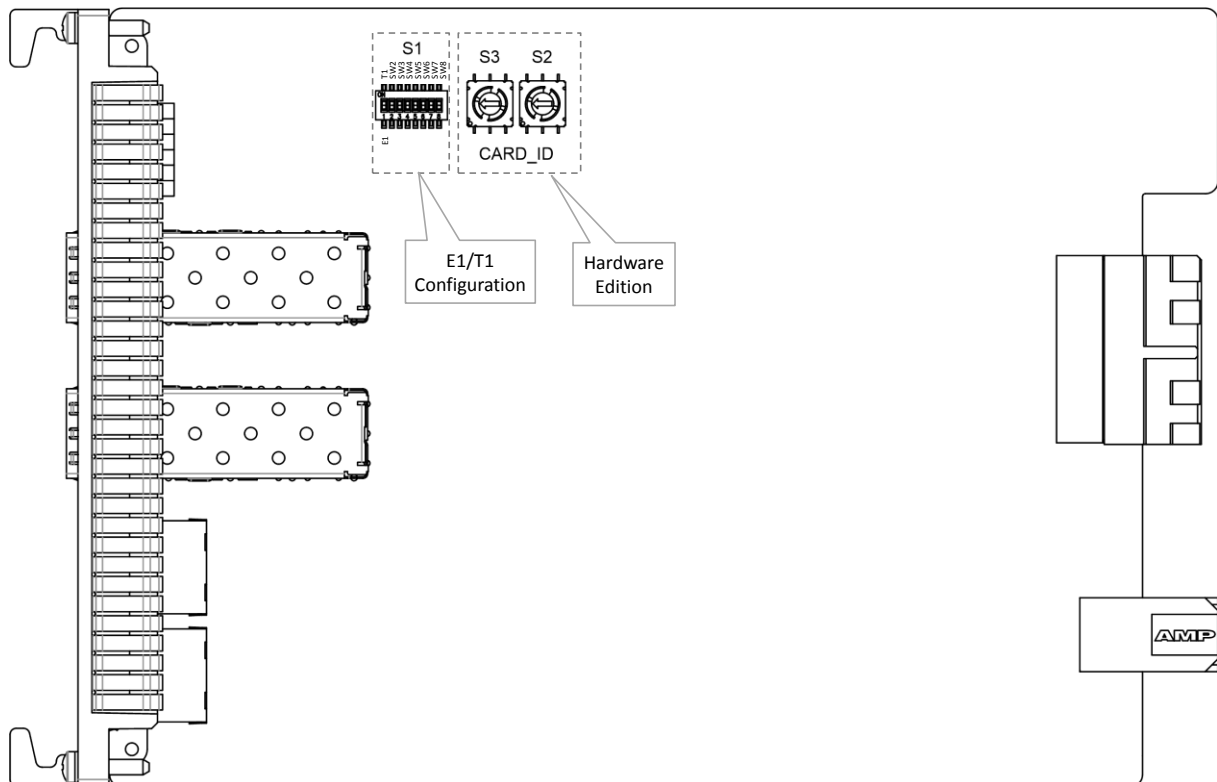

Figure 24 2-C37.94: Side View

### 2.3.1 Straps

No user relevant straps.

### 2.3.2 DIP Switches

#### a. Hardware Edition

The Hardware Edition (Figure 24) is set in decimal code using rotary switches S2 to S3 (=most significant). It can be read out as well via HiProvision. This edition has been factory set and **MUST NOT BE CHANGED!**

Example: Setting S3='0' and S2='5' indicates Hardware Edition '5' (dec).

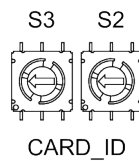
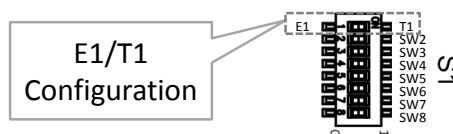

**Figure 25 Hardware Edition**

#### b. E1/T1 Configuration

The E1/T1 configuration of the 2-C37.94 module is factory set via the E1/T1 DIP switch indicated in Figure 24 and Figure 26 and must not be changed. This switch is only relevant for the E1/T1 ports. The configuration can be read out via HiProvision. For more information on E1/T1 framing see §2.2.2/§2.2.3.

- ▶ Switch = E1: both E1/T1 ports operate as E1 ports, use the '2-C37.94-E1-L' IFM in HiProvision;
- ▶ Switch = T1: both E1/T1 ports operate as T1 ports, use the '2-C37.94-T1-L' IFM in HiProvision.



**Figure 26 E1/T1 Configuration**

## 3. TDM FRAMES/PACKET

### 3.1 General

The amount of TDM Frames per Ethernet packet is an important setting because it influences the amount of consumed bandwidth and delay through the network. The more TDM Frames/Package, the less bandwidth is used but the bigger the total delay through the network.

In HiProvision, it can be configured how many TDM Frames/Packet can be encoded. In the table below, find the minimum and maximum TDM Frames/Packet according the configured CES and the amount of used timeslots.

**NOTE:** Default TDM Frames/Packet = 4;

**Table 8 TDM Frames/Packet**

| CES     | Amount of Timeslots |           |           | Min. TDM Frames/Packet |    |        | Max. TDM Frames/Packet<br>(not hitless/hitless switching) |       |        |
|---------|---------------------|-----------|-----------|------------------------|----|--------|---|-------|--------|
|         | E1                  | T1        | C37.94    | E1                     | T1 | C37.94 | E1  | T1    | C37.94 |
| SAToP   | always 32           | always 24 | always 12 | 1                      | 1  | 1      | 24/10   | 24/10 | 24/10  |
| CESoPSN | 1                   | 1         | 1         | 3                      | 3  | 3      | 24/10   | 24/10 | 24/10  |
| CESoPSN | 2                   | 2         | 2         | 2                      | 2  | 2      | 24/10   | 24/10 | 24/10  |
| CESoPSN | 3 or 4              | 3 or 4    | 3 or 4    | 1                      | 1  | 1      | 24/10   | 24/10 | 24/10  |
| CESoPSN | 5..31               | 5..24     | 5..12     | 1                      | 1  | 1      | 24/10   | 24/10 | 24/10  |

### 3.2 Bandwidth

If only one TDM frame per packet is encoded, it generates a lot of header information on the network resulting in a lot of consumed bandwidth. Encoding more frames into one packet will decrease the amount of header information and as a result the consumed bandwidth as well. As of 8 frames per packet and higher, the bandwidth consumption stabilizes towards the minimum bandwidth consumption. See the graph below.

#### SAToP Bandwidth:

Y: Average Network Bandwidth (kbps)  
X: TDM Frames / Ethernet Packet

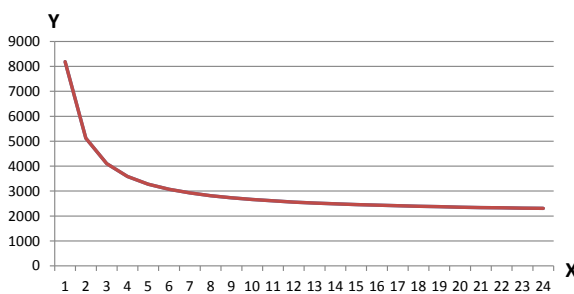

#### CESoPSN Bandwidth:

Y: Average Network Bandwidth (kbps)  
X: TDM Frames / Ethernet Packet

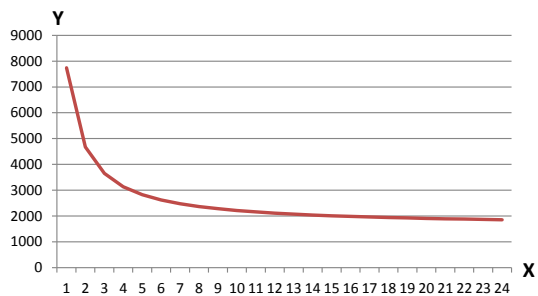

**Figure 27 SAToP, CESoPSN Bandwidth**

### 3.3 Delay

#### 3.3.1 General

The total delay between two end points over the Dragon PTN network depends on:

- ▶ **P** (=Packetization Delay): Delay to encode E1/T1/C37.94 input into MPLS-TP packets;
- ▶ **DP** (=Depacketization Delay): Delay to decode MPLS-TP packets into E1/T1/C37.94;

- ▶ **Path Delay:** Delay from source to destination over the MPLS-TP network path; can be measured by HiProvision via OAM delay measurement for the specific service; Path Delay = Delay external network (if any) +  $5\mu\text{s}/\text{km}$  +  $10\mu\text{s}/\text{node}$ ;
- ▶ **DPh:** Extra Depacketizing Delay due to hitless switching;
- ▶ **Total Delay** = Total Network delay between two E1/T1/C37.94 applications;
- ▶ **Total Delay** = (Packetization + Path + Depacketization + Hitless Switching) Delay;

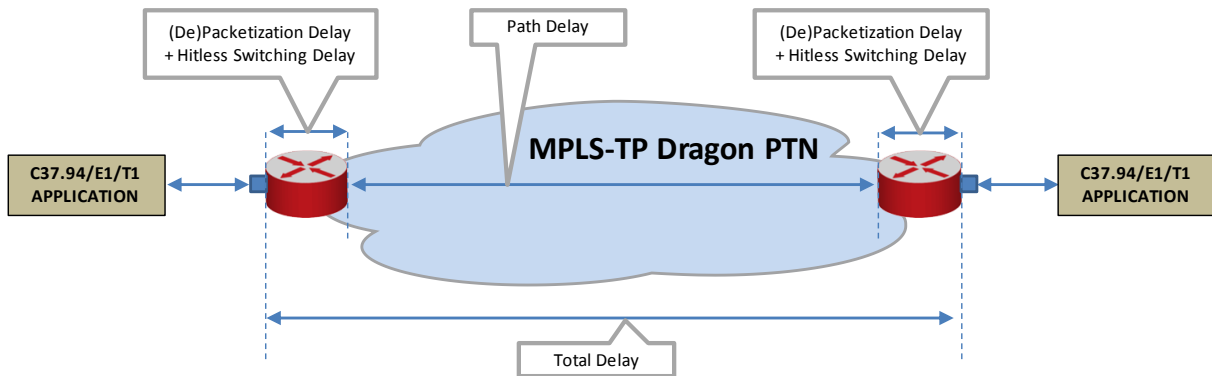

Figure 28 Delays

### 3.3.2 Delay Parameters

These delays in §3.3.1 depend on the selected service in HiProvision and its configured delay parameters. HiProvision offers the delay parameters listed below to tune the delay.

**CAUTION: If you are not familiar with these parameters, keep the default values.**

- ▶ **TDM Frames per Packet:** The lower the value, the lower the delay.
- ▶ **Jitter Buffer Size ( $\mu\text{s}$ ):** advice: Set this value to 'Packetizing Delay + expected peak-to-peak jitter ( $\mu\text{s}$ )'; the default peak-to-peak jitter could be  $250\ \mu\text{s}$ ; the expected peak-to-peak jitter ( $\mu\text{s}$ ) must be measured in the network. If the packetizing delay 'P'  $< 2000\ \mu\text{s}$ , set the buffer size to at least  $2000\ \mu\text{s}$ . If the packetizing delay 'P'  $> 2000\ \mu\text{s}$  (e.g.  $2500\ \mu\text{s}$ ), set the buffer size to at least e.g.  $2500\ \mu\text{s}$ .

**CAUTION: By default, the jitter buffer will reset once for optimal processing 15 seconds after a change in the service occurs. This reset will cause a minimal loss of data. See 'jitter buffer' in the 'Dragon PTN and HiProvision Operation' Manual (=Ref. [1]) for more information.**

- ▶ **Maximum Network Path Delay Difference ( $\mu\text{s}$ )** (only for Hitless Switching): advice: Set this value to '(Two Paths nodes difference)\*10 + expected peak-to-peak jitter ( $\mu\text{s}$ )'. If path1 has 17 nodes and path2 has 8 nodes, this is a difference of 9 nodes. You could set  $\text{MaxNetwPathDelayDiff} = 9*10 + 250 = 340\ \mu\text{s}$ ;

### 3.3.3 Estimated Delay Calculation and Formulas

Table 9 shows formulas to calculate an estimated delay. Once you have the desired estimated delay, fill out the parameter values in HiProvision, which shows the calculated 'P+DP+DPH'.

**Table 9 Estimated Delay Formulas**

| Delay        | No Hitless Switching                | Hitless Switching (SATOP)                | Hitless Switching (CESOP)                 |
|--------------|-------------------------------------|--|---|
| P            | TDMFramesPerPacket * 125            |  |   |
| Path Delay   | measured by HiProvision             |  |   |
| DP           | $(\text{JitterBufferSize} - P) / 2$ |  |   |
| DPh          | 0                                   | $2P + \text{MaxNetwPathDelayDiff} + 766$ | $2P + \text{MaxNetwPathDelayDiff} + 1087$ |
| <b>Total</b> | $P + \text{Path Delay} + DP + DPh$  |  |   |

### 3.3.4 Estimated Delay Examples

Find some example values below. Fill them out in the formulas to find the estimated total delay:

- ▶ TDMFramesPerPacket = 10
- ▶ Pathdelay (measured by HiProvision) = 500  $\mu\text{s}$
- ▶ JitterBufferSize = 4000  $\mu\text{s}$
- ▶ MaxNetwPathDelayDiff = 340  $\mu\text{s}$

**Table 10 Estimated Delay ( $\mu\text{s}$ ) Examples**

| Delay        | No Hitless Switching                               | Hitless Switching (SATOP)                             | Hitless Switching (CESOP)                             |
|--------------|--|---|---|
| P            | <u>10</u> * 125 = 1250                             |   |   |
| Path Delay   | <u>500</u>   |   |   |
| DP           | $(\text{4000} - 1250) / 2 = 1375$                  |   |   |
| DPh          | 0  | $2 * 1250 + \text{340} + 766 = 3606$                  | $2 * 1250 + \text{340} + 1087 = 3927$                 |
| <b>Total</b> | $1250 + 500 + 1375 + 0 = \text{3125 } \mu\text{s}$ | $1250 + 500 + 1375 + 3606 = \text{6731 } \mu\text{s}$ | $1250 + 500 + 1375 + 3927 = \text{7052 } \mu\text{s}$ |

### 3.3.5 Differential Delay

Differential Delay is the difference in Path Delays between two end-points, measured in two opposite directions over the same path.

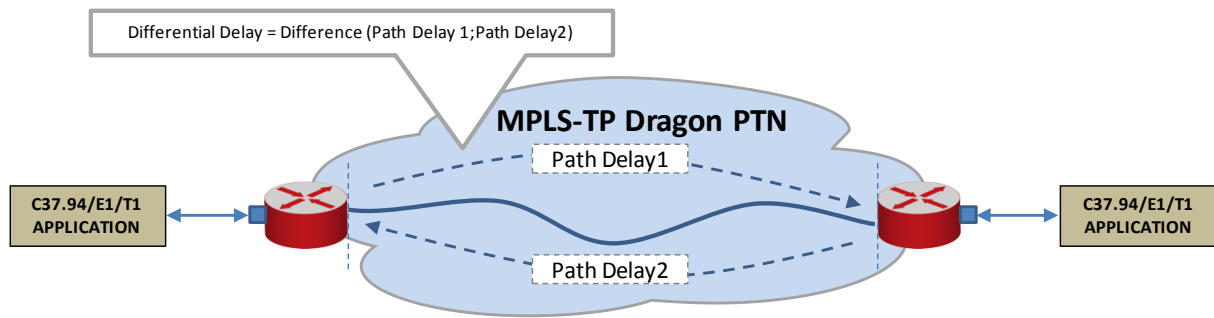

**Figure 29 Differential Delay**

When Differential Delay is very important for your application, we strongly advise to:

- ▶ Not use Hitless Switching with Single Path (§2.2.11), all the other modes are OK;
- ▶ Use SAToP (§2.2.6) when the differential delay must be as low as possible:
  - ▶ Maximum differential delay SAToP: 157  $\mu$ s;
  - ▶ Maximum differential delay CESoPSN: 1125  $\mu$ s;

### 3.4 Tuning CES = Tuning TDM Frames/Packet

Tuning the CES is mainly done by tuning the TDM Frames/Packet parameter. Tuning this parameter is a trade-off between bandwidth and delay. The more bandwidth is consumed the less the resulting network delay and vice versa. This tuning is application dependent. Check out whether bandwidth or delay is critical for an application or network. Based on these findings, bandwidth and delay parameters can be tuned.

Some examples according the information in §3.2 and §3.3:

- ▶ if bandwidth is not a problem, and a small delay is wanted → 1-6 TDM frames/packet;
- ▶ if less bandwidth is required and delay is not important → at least 8 TDM frames/packet;
- ▶ if less bandwidth and a small delay are wanted → 8 .. 10 TDM frames/packet.

## 4. COMPATIBILITY

The 2-C37.94 IFM is compatible with:

- ▶ 16-E1-L/16-T1-L IFM;
- ▶ 4-E1-L/4-T1-L IFM.

It means that:

- ▶ The E1 ports of a 4-E1-L, 16-E1-L and 2-C37.94 can be programmed in the same service;
- ▶ The T1 ports of a 4-T1-L, 16-T1-L and 2-C37.94 can be programmed in the same service;
- ▶ A C37.94 port and any E1 port on any IFM can be programmed in the same E1 CES service;
- ▶ A C37.94 port and any T1 port on any IFM can be programmed in the same T1 CES service;

## 5. MODULE SPECIFICATIONS

### 5.1 General Specifications

For general specifications like temperature, humidity, EMI... see Ref.[7] in Table 1.

### 5.2 Other Specifications

**Table 11 Other Specifications**

| Description       | Value   |
|-------------------|---|
| Weight            | 0.22 kg / 0.5 lb (without SFPs)<br>0.25 kg / 0.6 lb (including SFPs)                        |
| MTBF              | 140 years at 25°C/77°F  |
| Power Consumption | 8.1 W (measured at 25°C/77°F, with data transport and two SFPs)                             |
| Module Size       | width: 20.32 mm / 0.8 inches<br>height: 126 mm / 4.96 inches<br>depth: 195 mm / 7.68 inches |
| Power Consumption | 27W (measured at 25°C/77°F, with data transport)  |

### 5.3 Ordering Information

- ▶ PTN-2-C37.94: 942 236-009.

## 6. ABBREVIATIONS

|                |  |
|----------------|--|
| <b>AIS</b>     | Alarm Indication Signal                                |
| <b>AMI</b>     | Alternate Mark Inversion                               |
| <b>BERT</b>    | Bit Error Ratio Tester                                 |
| <b>CE</b>      | Conformité Européenne                                  |
| <b>CES</b>     | Circuit Emulation Service                              |
| <b>CESoPSN</b> | Circuit Emulation Service over Packet Switched Network |
| <b>CSM</b>     | Central Switching Module                               |
| <b>EFM-C</b>   | Ethernet in the First Mile Over Point-to-Point Copper  |
| <b>EMI</b>     | Electromagnetic Interference                           |
| <b>ERR</b>     | Error  |
| <b>ESF</b>     | Extended Super Frame                                   |
| <b>ETH</b>     | Ethernet   |
| <b>FLT</b>     | Fault  |
| <b>HDB3</b>    | High Density Bipolar of Order 3                        |
| <b>IEEE</b>    | Institute of Electrical and Electronics Engineers      |
| <b>IFM</b>     | InterFace Module                                       |
| <b>kbps</b>    | Kilobit per Second                                     |

|                |   |
|----------------|---|
| <b>LAN</b>     | Local Area Network                                |
| <b>LOS</b>     | Loss Of Signal                                    |
| <b>LVD</b>     | Low Voltage Directive                             |
| <b>Mbps</b>    | Megabit per Second                                |
| <b>MPLS-TP</b> | MultiProtocol Label Switching – Transport Profile |
| <b>MSB</b>     | Most Significant Bit                              |
| <b>MTBF</b>    | Mean Time Between Failures                        |
| <b>NTR</b>     | Network Timing Reference                          |
| <b>OAM</b>     | Operations, Administration and Maintenance        |
| <b>PBX</b>     | Private Branch Exchange                           |
| <b>PF</b>      | Power Failure                                     |
| <b>PI</b>      | Power Input                                       |
| <b>PTN</b>     | Packet Transport Network                          |
| <b>PTP</b>     | Point to Point                                    |
| <b>RDI</b>     | Remote Defect Indication                          |
| <b>SAToP</b>   | Structure Agnostic TDM over Packet                |
| <b>SF</b>      | Super Frame                                       |
| <b>SFP</b>     | Small Form-Factor Pluggable                       |
| <b>SyncE</b>   | Synchronous Ethernet                              |
| <b>TDM</b>     | Time Division Multiplex                           |
| <b>WAN</b>     | Wide Area Network                                 |