



HIRSCHMANN

A **BELDEN** BRAND

User Manual

Installation

Dragon PTN

Aggregation Node PTN2210: 1 NSM, 2 PSUs, 2 CSMs, 10 IFMs

Aggregation Node PTN2209: 1 NSM, 2 PSUs, 2 CSMs, 9 IFMs

Aggregation Node PTN2206: 1 NSM, 2 PSUs, 2 CSMs, 6 IFMs

Aggregation Node PTN1104: 1 NSM, 1 PSU, 1 CSM, 4 IFMs



The naming of copyrighted trademarks in this manual, even when not specially indicated, should not be taken to mean that these names may be considered as free in the sense of the trademark and tradename protection law and hence that they may be freely used by anyone.

© 2018 Hirschmann Automation and Control GmbH

Manuals and software are protected by copyright. All rights reserved. The copying, reproduction, translation, conversion into any electronic medium or machine scannable form is not permitted, either in whole or in part. An exception is the preparation of a backup copy of the software for your own use.

The performance features described here are binding only if they have been expressly agreed when the contract was made. This document was produced by Hirschmann Automation and Control GmbH according to the best of the company's knowledge. Hirschmann reserves the right to change the contents of this document without prior notice. Hirschmann can give no guarantee in respect of the correctness or accuracy of the information in this document.

Hirschmann can accept no responsibility for damages, resulting from the use of the network components or the associated operating software. In addition, we refer to the conditions of use specified in the license contract.

You can get the latest version of this manual on the Internet at the Hirschmann product site (www.doc.hirschmann.com).

Hirschmann Automation and Control GmbH
Stuttgarter Str. 45-51
72654 Neckartenzlingen
Germany

Contents

1.	INTRODUCTION	5
1.1	General	5
1.2	Manual References	6
2.	NODE DESCRIPTION	7
2.1	General	7
2.1.1	Node XT-2210-A.....	7
2.1.2	Node XT-2209-A.....	7
2.1.3	Node XT-2206-A.....	8
2.1.4	Node XT-1104-A.....	8
2.2	NSM (=Node Support Module)	9
2.2.1	General	9
2.2.2	Functions	10
2.2.3	PoE (=Power Over Ethernet) (only on NSM-A).....	15
2.3	PSU (=Power Supply Unit)	17
2.3.1	Node PSUs.....	17
2.3.2	PoE PSUs (only on NSM-A)	20
2.4	CSM (=Central Switching Module)	24
2.4.1	General	24
2.4.2	CSM Redundancy.....	24
2.5	IFM (=Interface Module)	24
2.6	Backplane	24
2.7	PE: Protective Earth	25
2.8	Cooling / Temperature Sensing	25
2.9	Add a New Node to a Live Network	25
3.	SPECIFICATIONS	26
3.1	General Specifications	26
3.2	Weight	26
3.3	MTBF	26
3.4	Power Consumption (Empty Node)	26
3.5	Dimensions	26
3.6	Cooling	27
3.7	Input Voltage Range	27
3.8	Digital Output Contacts	27
3.9	Ordering Information	27
4.	INSTALLATION INSTRUCTIONS	27
5.	WEEE GUIDELINES	27
6.	ABBREVIATIONS	28

List of figures

Figure 1 Dragon PTN MPLS-TP Network.....	6
Figure 2 XT-2210-A Node	7
Figure 3 XT-2209-A Node	8
Figure 4 XT-2206-A Node	8
Figure 5 XT-1104-A Node	8
Figure 6 NSM-A, NSM-B: Front Panel	10
Figure 7 NSM-A: Side View	11
Figure 8 Example: Node Number 219	11
Figure 9 DI, DO RJ45 Connector	13
Figure 10 Example: Digital Input (=DI): Closed Input	14
Figure 11 DO Contact Behavior: No Alarm/Alarm.....	15
Figure 12 Alarming via Digital Output (=DO) Contacts.....	15
Figure 13 General PoE Example	16
Figure 14 ACP-A PSU with Power Cable	17
Figure 15 DCP-A PSU (18-60VDC) / Power Cable / Code Keys	18
Figure 16 DCP-B PSU (88-300VDC) / Power Cable / Code Keys	19
Figure 17 ACPoE-A PSU to NSM-A Connection	21
Figure 18 Output Current, Power Derating.....	22
Figure 19 DCPoE-A PSU to NSM Connection.....	23
Figure 20 PE: Protective Earth.....	25
Figure 21 Crossed-Bin Symbol.....	28

List of Tables

Table 1 Manual References.....	6
Table 2 Product Ordering Numbers	6
Table 3 LED Indications in Boot Operation.....	12
Table 4 LED Indications in Normal Operation	12
Table 5 DI Pin Allocation.....	13
Table 6 DO Pin Allocation	14
Table 7 DCP-A PSU (18-60VDC) / Power Cable / Code Keys.....	18
Table 8 DCP-B PSU (88-300VDC) / Power Cable / Code Keys.....	19
Table 9 Specifications: ACP-A PSU (100-240VAC± 10%)	20
Table 10 Specifications: DCP-A PSU (18-60VDC)	20
Table 11 Specifications: DCP-B PSU (88-300VDC)	20
Table 12 Specifications: ACPoE-A PSU.....	22
Table 13 Specifications: DCPoE-A PSU	23
Table 14 Product Weights	26
Table 15 Power Consumption	26

1. INTRODUCTION

1.1 General

This document is valid as of Dragon PTN Release 4.0DR.

The Dragon PTN product line has been designed for industrial MPLS-TP networks and consists of aggregation node types XT-2210-A, XT-2209-A, XT-2206-A and XT-1104-A.

NOTE: Aggregation nodes are the first generation nodes with speeds up to 10 Gbps. Core Nodes are the next generation high speed nodes with speeds up to 40 Gbps.

The Dragon PTN Nodes have a rugged industrial design and operate entirely fanless (no moving parts, except for the 9-L3A-L IFM (see Ref.[6] in Table 1)) and are compliant with the EMC standards listed in Ref.[5] in Table 1. All nodes are modular and 19" Rack or DIN Rail mountable. The more compact XT-1104-A and XT-2206-A node require an extra DIN Rail 19" rack mount kit for rack installation, see also 0 and Ref.[2] in Table 1 for an overview of the possible mounting kits.

CAUTION - DIN Rail Kits: It is not allowed that the Dragon PTN nodes equipped with a normal or Heavy duty DIN Rail kit, are attached to a DIN Rail in the Rack during transport of the Rack. Hirschmann Automation and Control GmbH shall not be held responsible for any damage to the node or any consequential 3rd party equipment damage. Hirschmann Automation and Control GmbH will not provide any warranty if the above recommendation has been ignored.

All nodes are equipped with a Node Support module (=NSM), which hosts functions like I/O contacts and inputs for external PoE (=Power Over Ethernet, only on NSM-A) power supplies.

A node requires at least an NSM, one power supply unit (=PSU) and one central switching module (=CSM). Each node provides a number of slots for interface modules to communicate with applications like Ethernet, SHDSL, E1/T1, C37.94 ...

Node XT-1104-A is ultra-compact and can host a single PSU and CSM and has 4 interface slots. Node XT-2210-A can be equipped with dual PSUs and dual CSMs for redundancy purposes and has 10 interface slots. Node XT-2206-A is similar to node XT-2210-A but offers 6 interface slots instead of 10. XT-2209-A is similar to XT-2210-A but is optimized for the 9-L3A-L IFM, see Ref[6] in Table 1. Nodes can be interconnected via copper cable or optical fiber. An example of a Dragon PTN network can be found in the figure below. The network is managed by a HiProvision PC (=Dragon PTN Management System), see also Ref. [1] in Table 1.

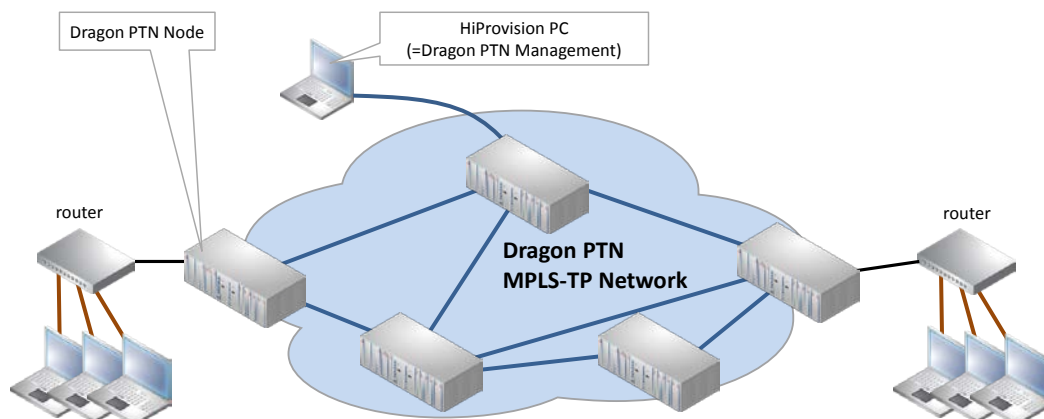

Figure 1 Dragon PTN MPLS-TP Network

1.2 Manual References

Table 1 is an overview of the manuals referred to in this manual. ‘&’ refers to the language code, ‘*’ refers to the manual issue. All these manuals can be found in the HiProvision (=Dragon PTN Management System) Help function. 0 shows the ordering numbers.

Table 1 Manual References

Ref.	Number	Title
[1]	DRA-DRM821-&-*	Dragon PTN and HiProvision Operation
[2]	DRA-DRM801-&-*	Dragon PTN Installation and Operation
[3]	DRD-DRM803-&-*	Dragon PTN Central Switching Module: PTN-CSM310-A
[4]	DRE-DRM807-&-*	Dragon PTN Interface Module: PTN-4-GC-LW/ PTN-4-GCB-LW
[5]	DRA-DRM810-&-*	Dragon PTN General Specifications
[6]	DRE-DRM823-&-*	Dragon PTN Interface Module: PTN-9-L3A-L
[7]	DRA-DRM828-E-1	Dragon PTN Bandwidth Overview

Table 2 Product Ordering Numbers

Ordering Number	Description
942 228-004	Node: PTN2210 (NSM not included)
942 228-003	Node: PTN2209 (NSM not included)
942 228-002	Node: PTN2206 (NSM not included)
942 228-001	Node: PTN1104 (NSM not included)
942 256-001	19 Inch Rack Mount Kit for PTN2206
942 256-003	19 Inch Rack Mount Kit for PTN1104
942 256-004	19 Inch Rack Mount Kit for 2x PTN1104
942 256-002	Heavy duty DIN Rail kit for PTN2206
942 256-005	Heavy duty DIN Rail kit for PTN1104
942 229-001	Node Support Module (PTN-NSM-A)
942 229-002	Node Support Module (PTN-NSM-B)
942 234-001	PTN-ACP-A: AC PSU 100 to 240 VAC \pm 10 %
942 234-002	PTN-DCP-A: DC PSU 18 to 60 VDC
942 234-003	PTN-DCP-B: DC PSU 88 to 300 VDC
942 235-001	PTN-ACPoE-A: External DIN rail PSU (=AC 100-240 VAC Wide-range Input)
942 235-002	PTN-DCPoE-A: External DIN rail PSU (=33-62V Input)
942 237-001	PTN-BLANK-Module: Empty IFM cover plate
942 237-002	PTN-BLANK-PSU: Empty PSU cover plate
942 237-003	PTN-BLANK-CSM: Empty CSM cover plate
942 256-100	Europe: AC PSU Cable with locking mechanism (2.5m) for AC PSU 100 to 240 VAC \pm 10 %
942 256-101	UK: AC PSU Cable with locking mechanism (2.5m) for AC PSU 100 to 240 VAC \pm 10 %
942 256-102	US: AC PSU Cable with locking mechanism (2.5m) for AC PSU 100 to 240 VAC \pm 10 %
942 256-105	Cable (3m) to connect External DIN rail PoE PSU to the NSM

Ordering Number	Description
942 256-103	DC PSU Cable (3m) with coding keys for DC PSU 18 to 60 VDC
942 256-104	DC PSU Cable (3m) with coding keys for DC PSU 88 to 300 VDC

2. NODE DESCRIPTION

2.1 General

The Dragon PTN node consists of a 3 U (3 U = 132.5 mm = 5.22 inches) high, 19 inches rack or DIN rail mountable stainless steel (*) chassis. The EMC shielding of the chassis complies with the EMC standards listed in Ref.[5] in Table 1. Each node type has a modular structure. Depending on the customer needs, different node types are available, see paragraphs below.

NOTE: (*) Stainless steel according EN A2 1.4016.

2.1.1 Node XT-2210-A

The following modules can be installed from left to right (see Figure 2):

- ▶ Node Support Module (NSM);
- ▶ 2 Power Supply Units (PSU-1/PSU-2);
- ▶ 10 Interface Modules (IFM-1,..., IFM-10);
- ▶ 2 Central Switching Modules (CSM-1/CSM-2);

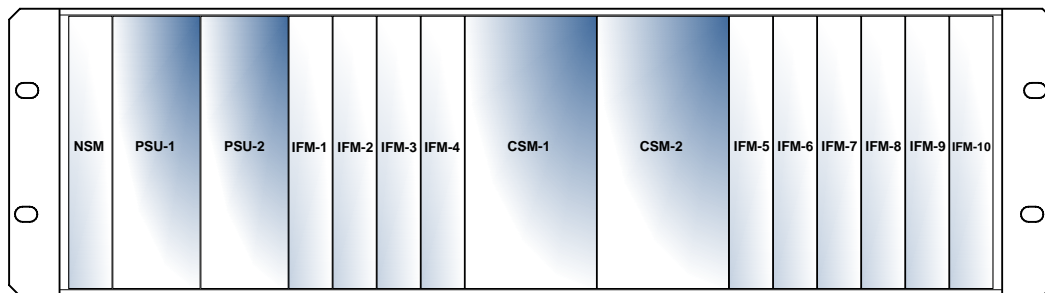

Figure 2 XT-2210-A Node

2.1.2 Node XT-2209-A

The following modules can be installed from left to right (see Figure 2):

- ▶ Node Support Module (NSM);
- ▶ 2 Power Supply Units (PSU-1/PSU-2);
- ▶ 1 wide IFM slot (IFM-3) optimized for a 9-L3A-L IFM (wider than normal IFMs). This slot (left-hand side) can also be used for normal IFMs;
- ▶ 9 Interface Modules (IFM-1,..., IFM-9);
- ▶ 2 Central Switching Modules (CSM-1/CSM-2);

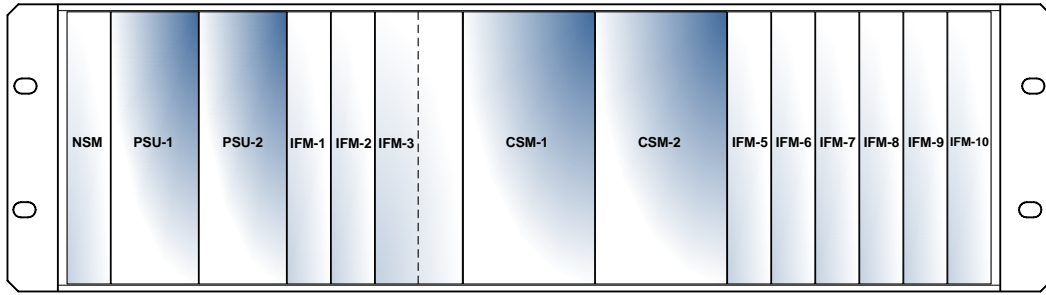

Figure 3 XT-2209-A Node

2.1.3 Node XT-2206-A

The following modules can be installed from left to right (see Figure 2):

- ▶ Node Support Module (NSM);
- ▶ 2 Power Supply Units (PSU-1/PSU-2);
- ▶ 6 Interface Modules (IFM-1,..., IFM-6);
- ▶ 2 Central Switching Modules (CSM-1/CSM-2);

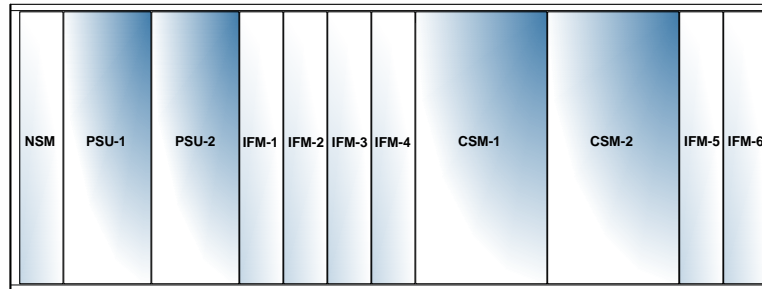

Figure 4 XT-2206-A Node

2.1.4 Node XT-1104-A

The following modules can be installed from left to right (see Figure 5):

- ▶ Node Support Module (NSM);
- ▶ 1 Power Supply Unit (PSU);
- ▶ 4 Interface Modules (IFM-1,...,IFM-4);
- ▶ 1 Central Switching Module (CSM);

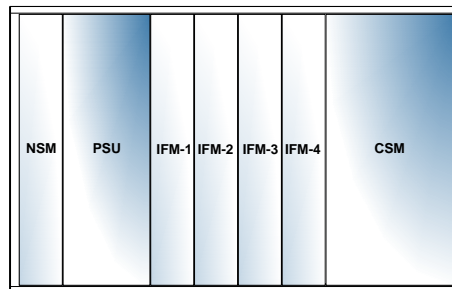

Figure 5 XT-1104-A Node

2.2 NSM (=Node Support Module)

2.2.1 General

The NSM is required in each Dragon PTN node and performs the functions below via its front panel. Make sure to tighten the NSM fastening screws after plugging in the NSM.

- ▶ Status indication of PSU(s) and CSM(s);
- ▶ Status and connection of Digital I/O;
- ▶ On NSM-A only: Status and connection of PoE Power inputs (redundant);
- ▶ Manual switch over of the active CSM via hidden push button;

The following functions can be performed via the module board itself (after unplugging it):

- ▶ Setting the Node Number via rotary DIP switches;
- ▶ Setting the NSM hardware edition (labeled as CARD_ID). This edition is factory set and must not be changed;

The NSM only communicates with the active CSM within its node and does not use Dragon PTN bandwidth. The NSM can be replaced and is hot-swappable.

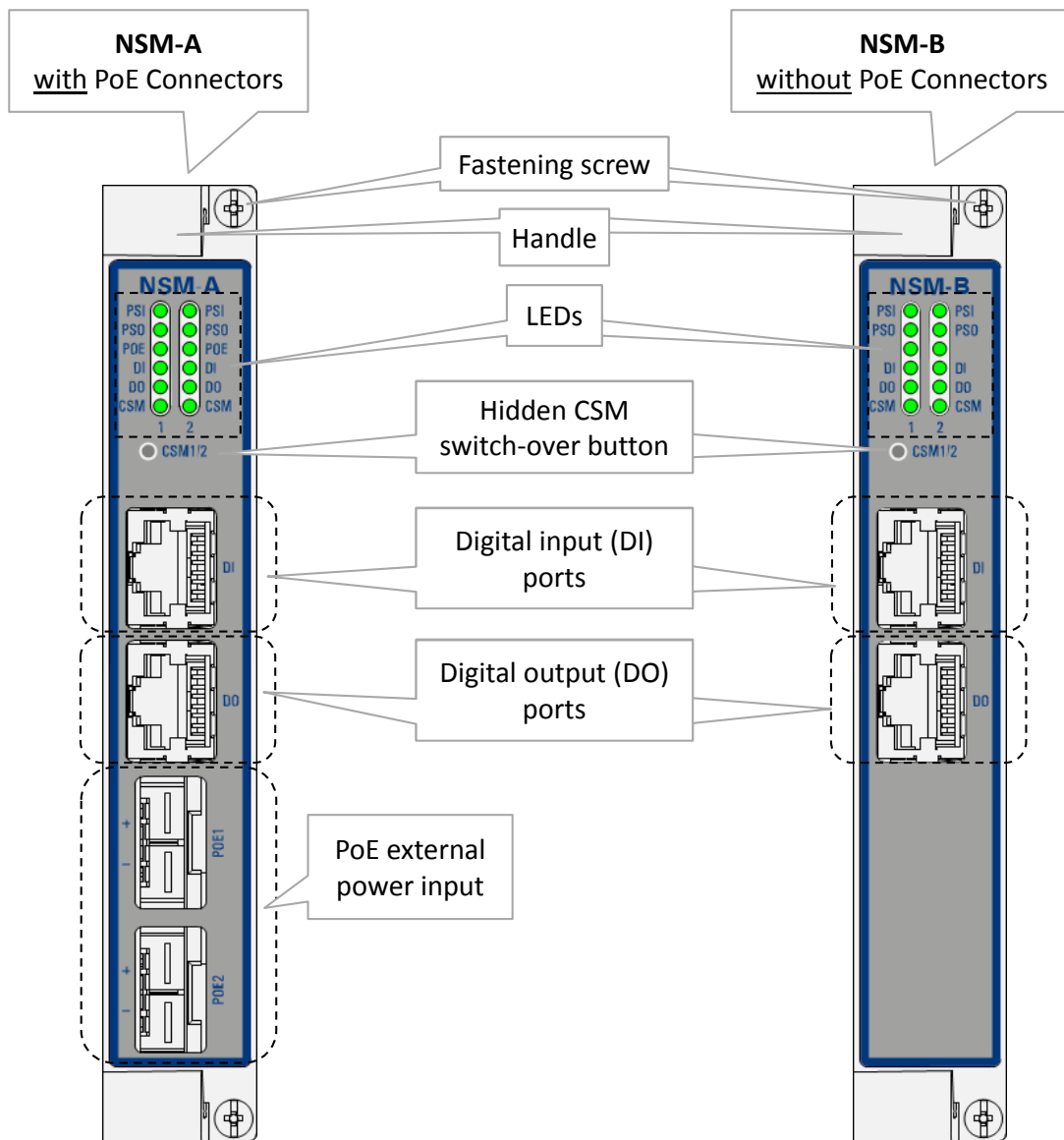

Figure 6 NSM-A, NSM-B: Front Panel

2.2.2 Functions

a. Rotary DIP Switch Settings

The **Hardware Edition** (labeled as CARD_ID) and **Node Number** on the NSM are set by rotary DIP switches. In order to access them, the NSM must be partly removed from the node chassis.

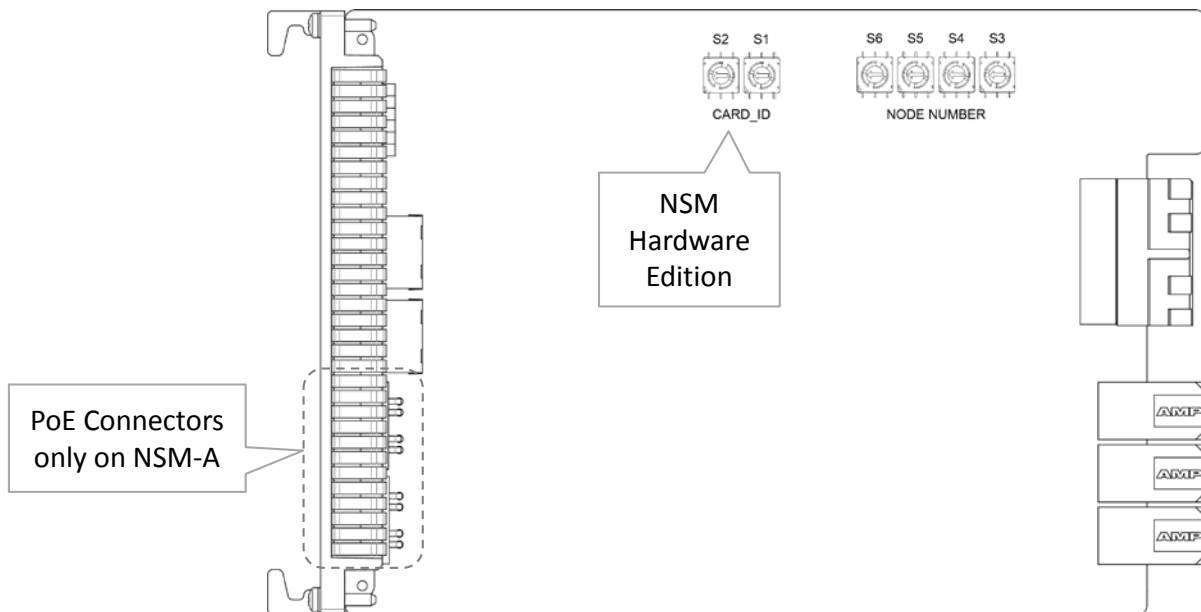

Figure 7 NSM-A: Side View

b. Node Number

Node numbers are set in decimal code using rotary switches S3 (=least significant) to S6 (=most significant). Valid decimal node numbers range from 0001 to 8999. The configured node number can be verified on the CSM display, see Ref.[3] in Table 1. An invalid configured node number would result in an error and node number '9001' on the display.

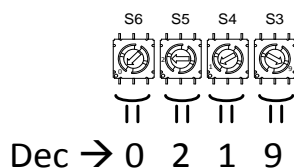

Figure 8 Example: Node Number 219

c. Hardware Edition

The hardware edition (labeled as CARD_ID) of the NSM has been factory set with rotary DIP switch S1 and S2 (=most significant) and **MUST NOT BE CHANGED!**

d. LED Indications

- ▶ PSI1/2 refers to the 'PSU-input' of the PSU in the PSU1/2 slot;
- ▶ PSO1/2 refers to the 'PSU-output' of the PSU in the PSU1/2 slot;
- ▶ Only on NSM-A: POE1/2 refers to the POE1/2 connectors. On the NSM-B, these LEDs are unused spare LEDs;
- ▶ DI1/2 refers to inputs1/2 on the digital input (=DI) connector on the NSM;
- ▶ DO1/2 refers to output contact1/2 on the digital output (=DO) connector on the NSM;
- ▶ CSM1/2 refers to the CSM plugged into CSM1/CSM2;

The meaning of the LEDs depends on the mode of operation (= boot or normal) in which the NSM currently is running. After plugging in the module or rebooting it, the module turns into the boot operation, see Table 3. After the module has rebooted successfully, after a few seconds), the module turns into the normal operation, see LEDs in Table 4.

Table 3 LED Indications in Boot Operation

Cycle	PSI1/2	PSO1/2	POE1/2 (only on NSM-A)	DI1/2	DO1/2	CSM1/2
1	x	x	---	---	---	---
2	x	x	---	---	x	---
3	x	x	---	---	---	---
x : LED is lit --- : LED is not lit The sub cycle times may vary. The entire boot cycle time [1→3] takes only a few seconds.						

Table 4 LED Indications in Normal Operation

LED	Color	Status
PSI1/2	Not lit, dark	The corresponding PSU does not receive input voltage from a power source.
	Green	The corresponding PSU receives input voltage from a power source.
PSO1/2	Not lit, dark	The corresponding PSU does not deliver +12V output voltage to the node.
	Green	The corresponding PSU delivers +12V output voltage to the node.
POE1/2 (only on NSM-A)	Not lit, dark	The corresponding POE connector does not receive external power.
	Green	The corresponding POE connector receives external power. This power can be used by the PoE ports on the interface modules which are plugged into the node.
DI1/2	Not lit, dark	No activity or current has been detected on the corresponding input.
	Green	Current has been detected on the corresponding input of the digital input connector (DI).
DO1	Not lit, dark	Minor alarm is active on DO1 contact, DO1 contact is deactivated or idle, see §2.2.2g.
	Green	No alarm is active on DO1 contact, DO1 contact is activated, see §2.2.2g.
DO2	Not lit, dark	Major alarm is active on DO2 contact, DO2 contact is deactivated or idle, see §2.2.2g.
	Green	No alarm is active on DO2 contact, DO2 contact is activated, see §2.2.2g.
CSM1/2	Not lit, dark	The corresponding CSM is not plugged in or, it is plugged in and in standby/passive mode in case of redundant CSMs.
	Green	The corresponding CSM is active.

e. Hidden CSM1/2 Switch-Over Button

A hidden button is installed on the NSM to force a switch-over from the active to the redundant standby CSM (not applicable on the XT-1104-A node).

Example:

- ▶ CSM1 = ACT or active = lit LED;
- ▶ CSM2 = STB or standby = dark LED;

To switch-over, push and hold the CSM1/2 switch-over button (approximately 6 seconds) until the CSM2 LED lights. The switch-over was successful resulting in CSM2 = ACT and CSM1 = STB;

f. DI (=Digital Input) Connector (RJ45)

Two digital inputs (=DI), to detect an open or closed potential free contact, are available via the DI RJ45 connector on the front panel, see Figure 6. Via these inputs, the NSM can pick up external events (e.g. opening door ...) and raise an appropriate alarm (e.g. 'door opened') with help text (e.g. 'close the door') and severity (e.g. major). These alarm properties can be assigned to these inputs via HiProvision. The normal behavior of the inputs can be configured as 'no current detected' or 'current detected' via HiProvision as well. Table 4 shows the pin allocations for the DI connector. A standard Ethernet cable can be used on this connector.

Furthermore, two input LEDs DI1/2 are available, see Table 3. A DI LED is lit when current is detected on the input.

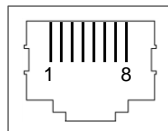

Figure 9 DI, DO RJ45 Connector

Table 5 DI Pin Allocation

Pin	DI (Input) Description
1	In1a
2	In1b
3	---
4	In2a
5	In2b
6	---
7	---
8	---

Inputs a and b are symmetrical. E.g. input1 (=In1), make a shortcut between pin In1a and In1b on the input to activate the input → current flows through the input, see figure below;

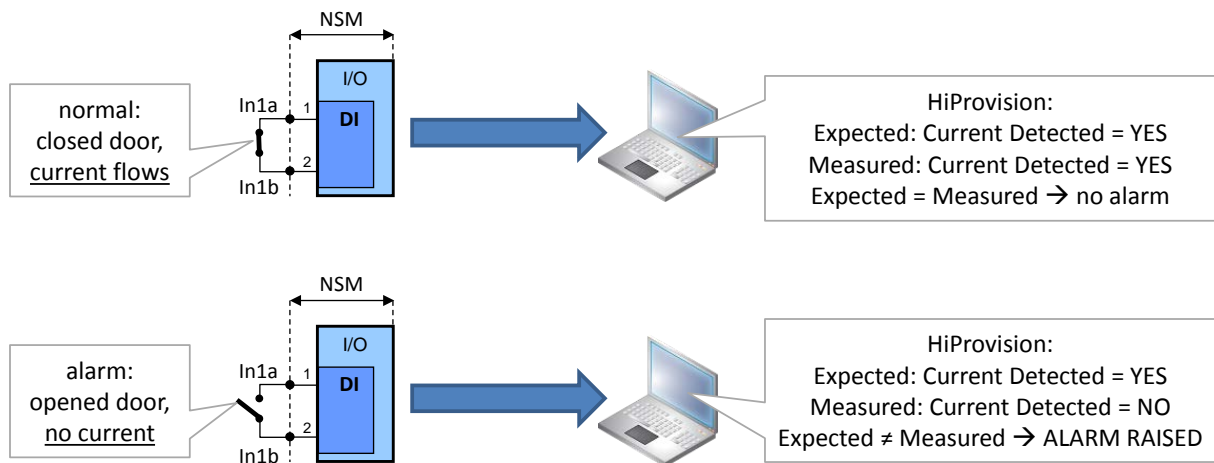

Figure 10 Example: Digital Input (=DI): Closed Input

g. DO (=Digital Output) Connector (RJ45)

Two digital output contacts (=DO) are available on the NSM front panel (Figure 6) for outputting minor/major alarms. These outputs can be used for example to activate an alarm siren. These alarms can be configured in HiProvision, see Ref. [1] in Table 1. The operation of these contacts influences the DO LEDs, see Table 4.

These contacts are change-over contacts on a relay activated by a logical '1'. Maximum current through such a contact: 1A DC; maximum voltage: 60 VDC. The DO connector in Figure 9 has following pin allocation:

Table 6 DO Pin Allocation

Pin	Contact	Pin Name	DO (Output) Description	Alarm
1	DO1	C1	Out Common 1	Minor Alarms
2	DO1	NC1	Out Normal Closed 1	
3	DO1	NO1	Out Normal Open 1	
4, 5	---	---	---	---
6	DO2	C2	Out Common 2	Major Alarms
7	DO2	NC2	Out Normal Closed 2	
8	DO2	NO2	Out Normal Open 2	

How the DO contacts behave in a normal (no alarm) and an alarm situation can be found in the figure below:

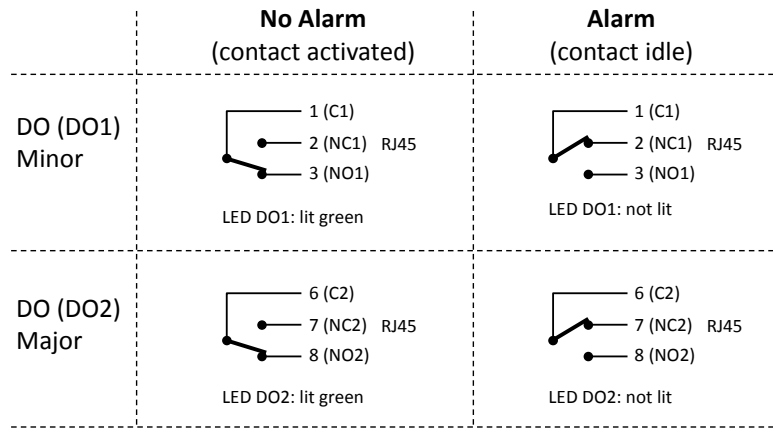

Figure 11 DO Contact Behavior: No Alarm/Alarm

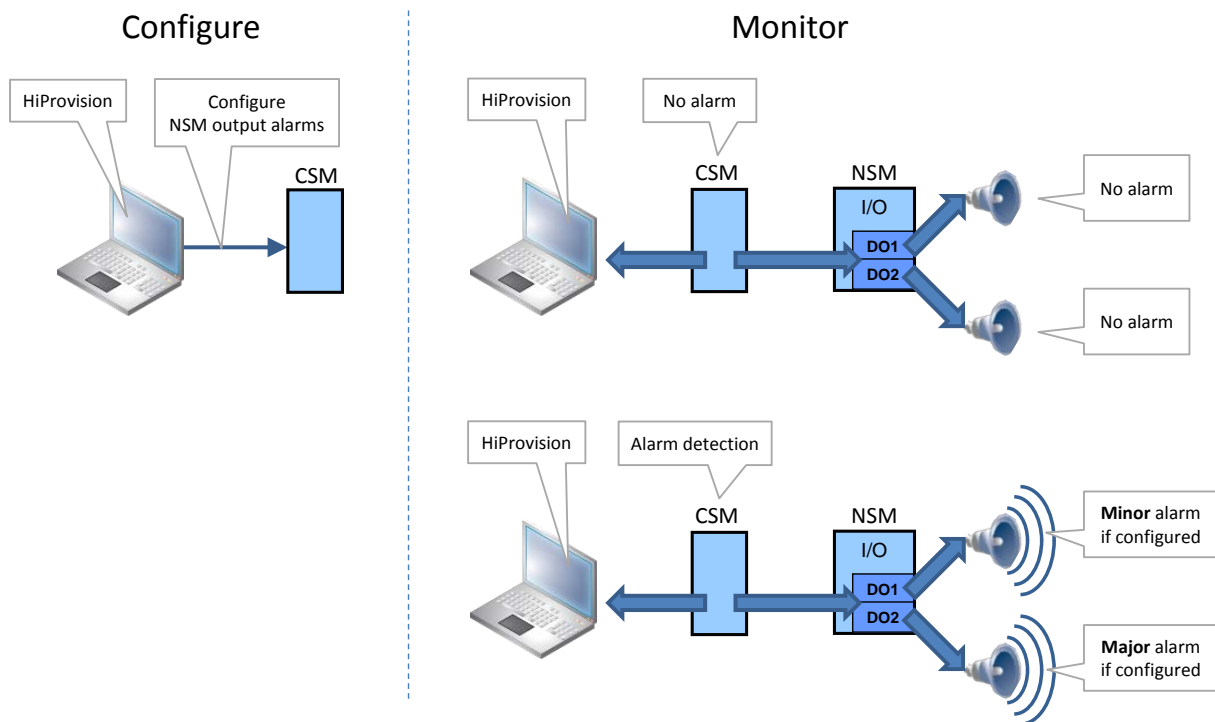

Figure 12 Alarming via Digital Output (=DO) Contacts

NOTE: A 'normal open output' contact is created between the 'C' and the 'NO' pin of that contact whereas a 'normal closed output' contact is created between the 'C' and the 'NC' pin of that contact.

NOTE: A standard Ethernet cable can be used on this connector.

2.2.3 PoE (=Power Over Ethernet) (only on NSM-A)

PoE is a technology that allows a Powered Device (=PD, e.g. IP telephones, IP cameras etc.) to receive power from 'Power Sourcing Equipment' (=PSE, e.g. the Dragon PTN node).

Dragon PTN nodes are able to deliver PoE when one (or two) external PoE PSU(s) is (are) connected to the NSM via the PoE connectors. A possible external PoE PSU and how to connect it can be found in §2.3.2.

The PD receives power in parallel to data, over the existing CAT-5 (or higher for more power) Ethernet infrastructure without it being necessary to make any modifications to it. PoE integrates data and power on the same cable, it keeps the structured cabling safe and does not interfere with concurrent network operation, see Figure 17.

PoE delivers a minimum of 48V of DC power over shielded/unshielded twisted-pair wiring for terminals consuming less than 25.5 Watts of power.

Before the power is delivered to a connected device, a protocol measures whether that device is a PoE device and how much power it needs (power classification). If required, the necessary power will be delivered by the PSE with a maximum of 40 Watts per port. PoE is supported on all the electrical RJ45 ports of the 4-GC-LW module. All these ports can deliver power according to the 802.3af (PoE) and 802.3at (PoE+) standard.

Via HiProvision it is possible to enable/disable PoE per port and to verify which ports in each node are PoE enabled.

(Future) Power management is supported, i.e. the Dragon PTN node decides in an intelligent way which PoE ports will get power and which ones will not. There are a lot of possible scenarios in which power management must tune its delivered power on each port. Some configuration/status parameters in HiProvision used by power management are:

- ▶ External PoE PSU power
- ▶ Available power budget
- ▶ Power Priority / Port Priority
- ▶ Power Class (class 0, 1, 2, 3, 4 configured and detected)
- ▶ Power management also offers PoE diagnostics in HiProvision.

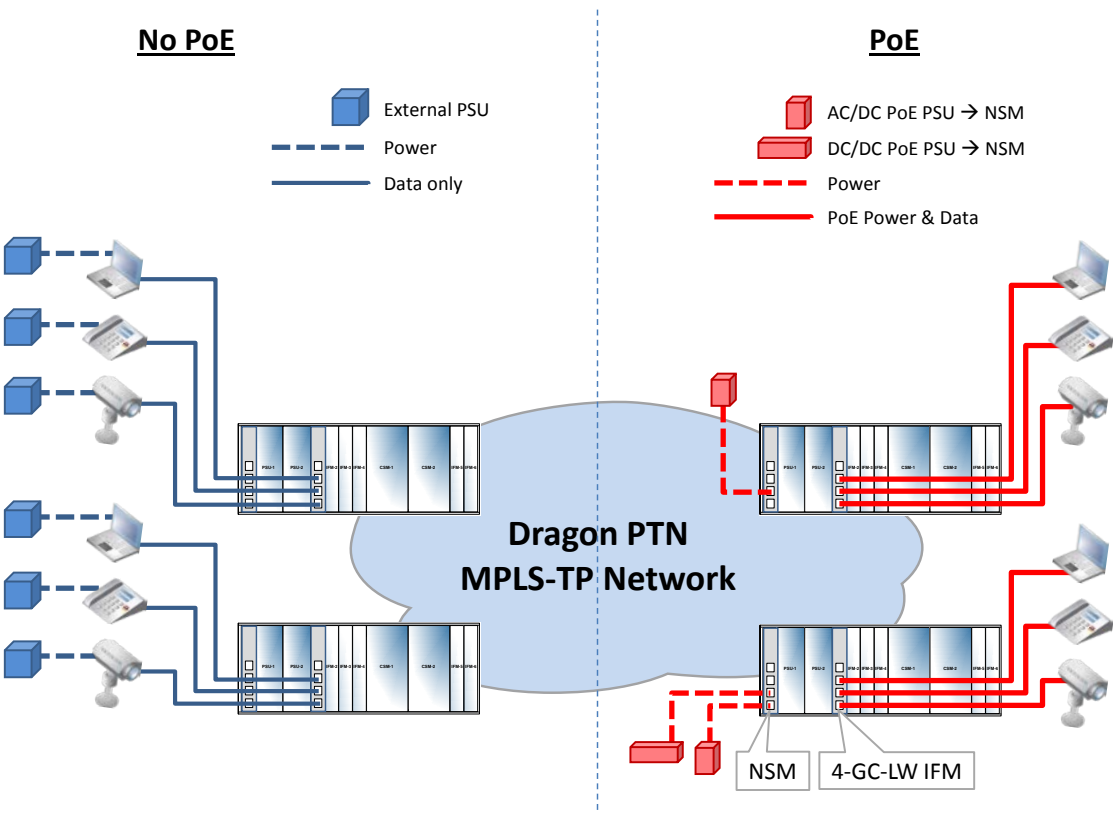

Figure 13 General PoE Example

2.3 PSU (=Power Supply Unit)

2.3.1 Node PSUs

PSU1 and/or PSU2 supply the voltage for all the modules in the node.

Three different power supplies are available, one AC PSU, one low voltage and one high voltage DC PSU. Node XT-2210-A, XT-2209-A and XT-2206-A can be equipped with dual PSUs for redundancy purposes. These two PSUs in one node can be of the same type or a mix of different types. If both PSUs are up and running, the load is shared over the two PSUs.

Make sure to tighten the PSU fastening screws after plugging in the PSUs.

The AC power cable has a locking mechanism. Both the DC PSUs and its power cable plug have unique coding keys (see figures below). A coding key is a physical obstruction in the PSU connector and cable with Phoenix plug to ensure that:

- ▶ only a high DC voltage (cable) can be connected to a high voltage DC PSU;
- ▶ only a low DC voltage (cable) can be connected to a low voltage DC PSU;

Following PSUs and cables are available:

a. AC PSU

- ▶ PSU ACP-A, 942 234-001: input voltage 100 to 240 VAC \pm 10 %;
- ▶ Power cables with locking mechanism are available for Europe, UK and US, 0.

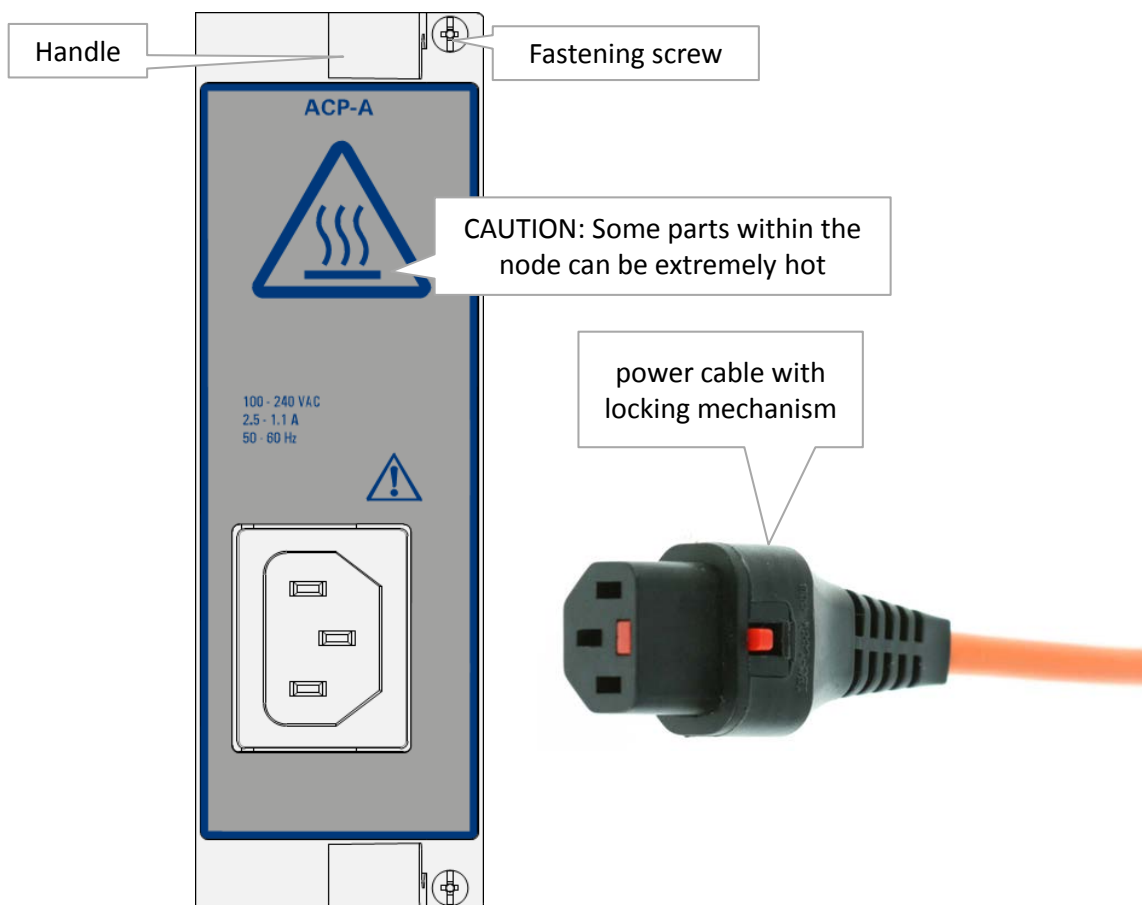

Figure 14 ACP-A PSU with Power Cable

b. DC PSU Low Voltage

- ▶ PSU DCP-A, 942 234-002: input voltage 18 to 60 VDC;
- ▶ Power cable (3m) with code keys: 942 256-103;

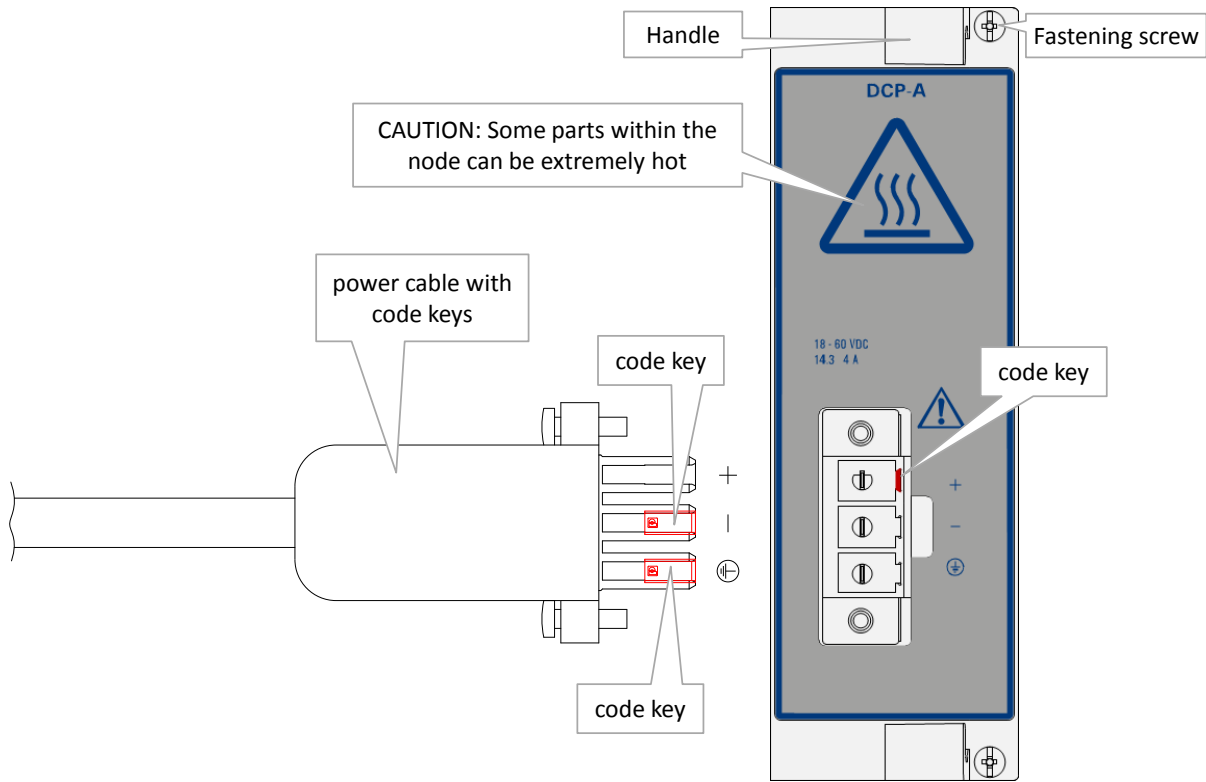

Figure 15 DCP-A PSU (18-60VDC) / Power Cable / Code Keys

Table 7 DCP-A PSU (18-60VDC) / Power Cable / Code Keys

Pin	PSU Side	Cable Side	Wire Color Codes
+	Code Key		BK with indication '1' or Brown
-		Code Key	BK with indication '2' or Blue
PE		Code Key	YE/GN

c. DC PSU High Voltage

- ▶ PSU DCP-B, 942 234-003: input voltage 88 to 300 VDC;
- ▶ Power cable (3m) with code keys: 942 256-104;

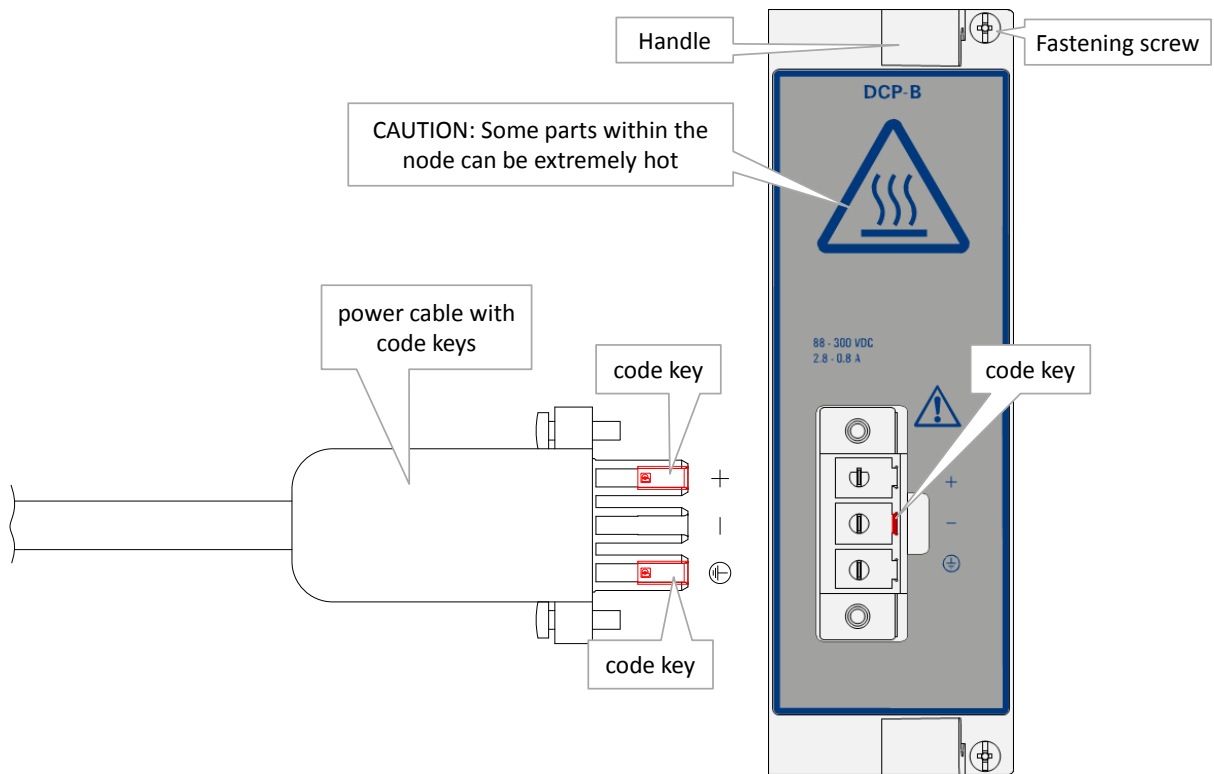

Figure 16 DCP-B PSU (88-300VDC) / Power Cable / Code Keys

Table 8 DCP-B PSU (88-300VDC) / Power Cable / Code Keys

Pin	PSU Side	Cable Side	Wire Color Codes
+		Code Key	BK with indication '1' or Brown
-	Code Key		BK with indication '2' or Blue
PE		Code Key	YE/GN

Some PSU LEDs (PSI1/2 and PSO1/2) indicate the operation of the PSUs, see Table 3.

The XT-2210-A/XT-2209-A/XT-2206-A node can operate with either one or two power supplies in any of the PSU positions. Any of the PSUs can be mixed in one node. The XT-1104-A node has one PSU slot available in which any of the PSUs can be used. An empty PSU slot in the XT-2210-A/XT-2209-A/XT-2206-A node must be covered with a cover plate, see 0.

The total output of the power supplies is rated at 175 Watt with 12V output at 65°C/149°F. The total power consumption of the equipped node is the sum of all the individual power consumptions of each module. Refer to the relevant module manuals for the power consumption of the CSM and IFMs. The tables below show the specifications of the AC and DC PSUs.

Table 9 Specifications: ACP-A PSU (100-240VAC± 10%)

Parameter	Condition / Remark	Value
Input		
Input voltage range	50-60Hz	100-240VAC ± 10%
Efficiency	At 230VAC and Pout is 220W At 110VAC and Pout is 220W	> 91% > 87%
Inrush current max.	Cold start 230V	30A
General		
MTBF (MIL-HDBK-217F)	At 25°C/77°F (GB)	> 34 years
Protections	Auto restart	Over temperature, Overcurrent
Input connector		IEC320 on front panel

Table 10 Specifications: DCP-A PSU (18-60VDC)

Parameter	Condition / Remark	Value
Input		
Input voltage range		18-60VDC (nominal 24VDC)
Efficiency	At 48VDC and Pout is 220W At 24VDC and Pout is 220W	> 90% > 88%
Inrush current max.	Cold start 48VDC	30A
General		
MTBF (MIL-HDBK-217F)	At 25°C/77°F (GB)	> 34 years
Protections	Auto restart	Over temperature, Overcurrent
Input connector		PCB side: PC 4/ 3-G-7,62 and BF-PC 4 Cable side: PC 4 HV/ 3-STF-7,62

Table 11 Specifications: DCP-B PSU (88-300VDC)

Parameter	Condition / Remark	Value
Input		
Input voltage range		88-300VDC (nominal 230VDC)
Efficiency	At 230VDC and Pout is 220W At 110VDC and Pout is 220W	> 91% > 87%
Inrush current max.	Cold start 230V	30A
General		
MTBF (MIL-HDBK-217F)	At 25°C/77°F (GB)	> 34 years
Protections	Auto restart	Over temperature, Overcurrent
Input connector		Pcb Side: GMSTB 2.5/3-GF-7.62-1806232 Cable side: GRMSTB 2.5/3-STF-7.62-1805990

2.3.2 PoE PSUs (only on NSM-A)

The NSM-A front panel has 2 PoE connectors to connect 2 external PoE sources or PSUs. One or two AC/DC (=ACPoE-A) or DC/DC (=DCPoE-A) PSUs, or a mix can be connected to the NSM.

Two connected PSUs will operate redundantly. Power aggregation is not supported. When two PSUs are connected, always the lowest power of both PSUs will be taken by HiProvision to calculate the PoE power.

For the configuration in HiProvision, see 'Power over Ethernet (PoE)' in the 'Dragon PTN and HiProvision operation manual', see Ref.[1] in Table 1.

Following PSUs can be ordered:

- ▶ ACPoE-A DIN Rail PSU (942 235-001), see below;
- ▶ DCPoE-A DIN Rail PSU (942 235-002), see below;

a. ACPoE-A DIN Rail PSU (942 235-001)

This ACPoE-A PSU has a wide-range input of 100-240VAC and an output range of 48-56VDC. The output voltage has been factory set to 56V.

In normal conditions, the continuously available power is 480W. As of higher ambient temperatures and as of an altitude of 2km, derating occurs resulting in less available output current and power, see Figure 18 .

Cable 942 256-105 (3m) must be used to connect the PoE source to the NSM, see below:

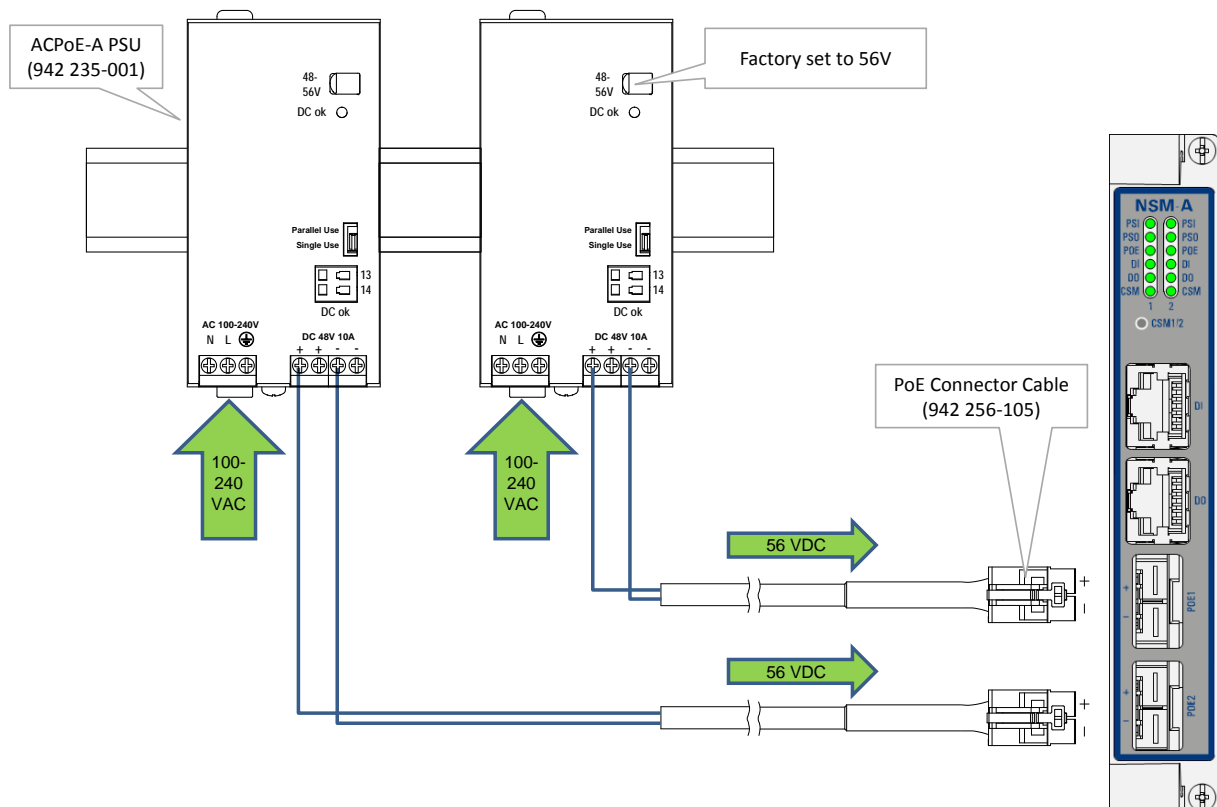

Figure 17 ACPoE-A PSU to NSM-A Connection

See the table below for the PoE PSU (942 235-001) specifications.

Table 12 Specifications: ACPoE-A PSU

Parameter	Condition / Remark	Value
Input		
Input voltage range		100-240VAC -15%/+10%
Mains frequency		50-60Hz ± 6%
AC Input current	At 120VAC At 230VAC	4.36A 2.33A
Output		
Output voltage		48VDC
Adjustment range		48 - 56VDC
Output current	Continuous	8.6 - 10A
Output power	Continuous	480 W
Parameter	Condition / Remark	Value
General		
MTBF (MIL-HDBK-217F)	At 25°C/77°F (GB)	AC100V: 40.5 years AC120V: 41 years AC230V: 45 years
Weight		1.0 kg / 2.2 lb
Derating		12W/°C at +60 to +70°C (6.6W/°F at 140 to 158°F), see also figures below.
Dimensions	WxHxD	65 x 124 x 127 mm / 2.56 x 4.88 x 5 inches
Protections	Auto restart	overload, no-load and short-circuits, overtemperature

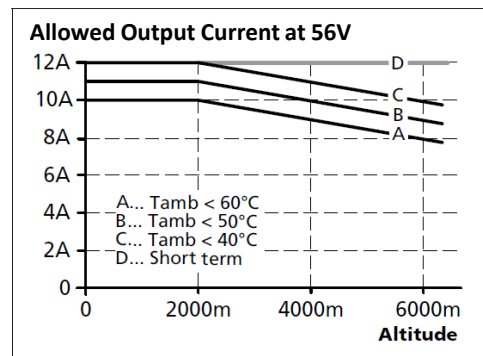
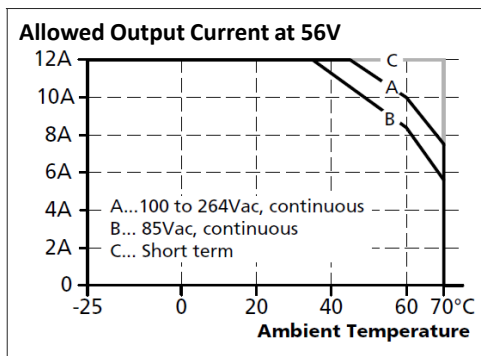

Figure 18 Output Current, Power Derating

b. DCPoE-A DIN Rail PSU or Wall Plate Mountable (942 235-002)

This DCPoE-A DIN rail PSU has an input range of 33-62VDC and an output of 56VDC. This PSU is DIN Rail or iron baseplate mountable. The wall plate can be used for better cooling. Cable 942 256-105 (3m) must be used to connect the PoE source to the NSM, see figure below:

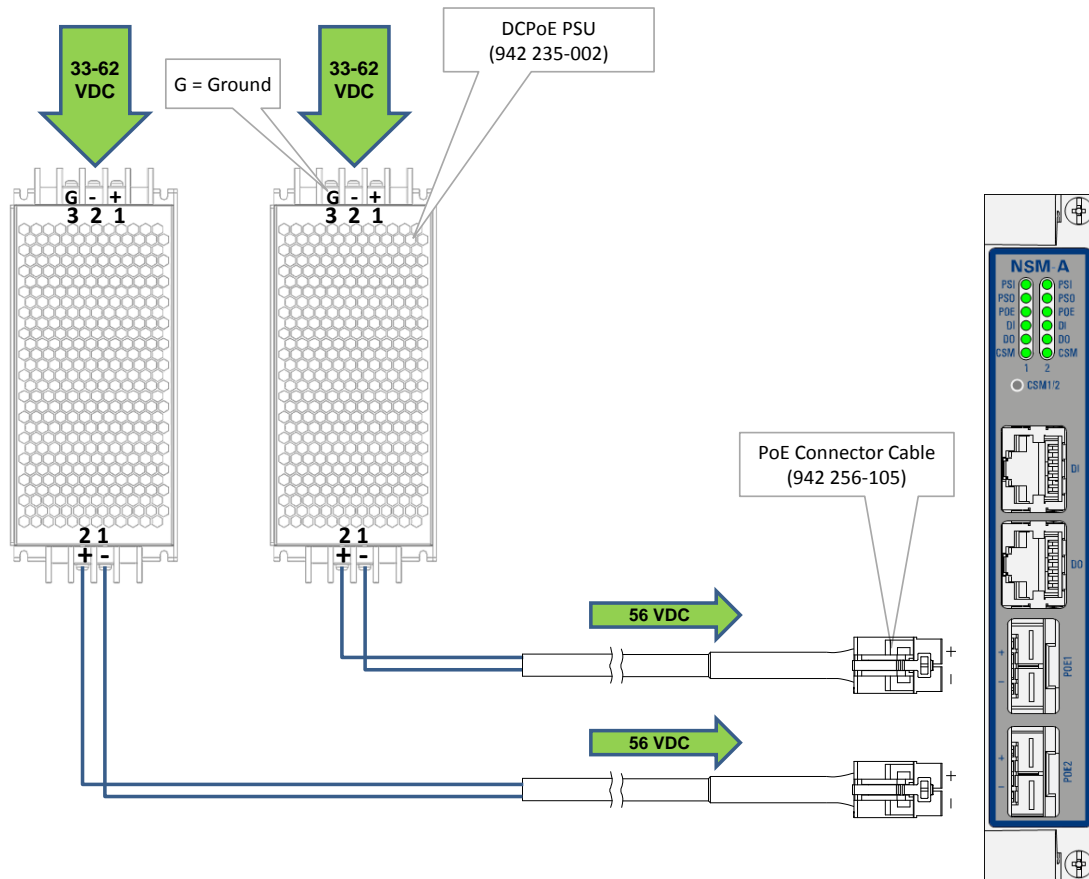

Figure 19 DCPoE-A PSU to NSM Connection

See table below for the PoE PSU (942 235-002) specifications.

Table 13 Specifications: DCPoE-A PSU

Parameter	Condition / Remark	Value
Input		
Input voltage range	Continuous	33.6 ~ 62.4VDC
Efficiency		92%
Inrush Current		45A
DC Input current		7.2A
Output		
Output voltage		56VDC
Output rated current		6.3A
Output rated power		302 W
General		
MTBF (MIL-HDBK-217F)	At 25°C/77°F (GB)	14.8 years
Weight		1.2 kg / 2.6 lb
Derating		-40°C/-40°F ~ +55°C/131°F (no derating) ; +70°C/158°F @ 60% load by free air convection ; +70°C/158°F no derating with external iron base plate, TX class compliance
Dimensions	WxHxD	97 x 40 x 216 mm / 3.82 x 1.57 x 8.5 inches
Protections	Auto recover Repower	Overload (auto recover) Overvoltage (must be repowered) Overtemperature (autorecover)

2.4 CSM (=Central Switching Module)

2.4.1 General

The XT-2210-A/XT-2209-A/XT-2206-A node can host two redundant CSMs, the XT-1104-A node can host one. The CSM is the heart of the node and controls communication between the different interface modules. It also provides the interface to HiProvision (=Dragon PTN Management System).

The node or the CSM itself exchanges services data (Ethernet, MPLS-TP, E1/T1, SHDSL...) with the outside world via the interface modules that are plugged into the Dragon PTN node. This means that a Dragon PTN node only communicates with other Dragon PTN nodes via its interface modules, not via the CSM itself. The only data that enters/leaves the front panel of the CSM is the management data to HiProvision.

2.4.2 CSM Redundancy

CSM Redundancy means that two CSMs are installed in the node. One CSM will be the active one while the other CSM will be the standby one.

CSM Redundancy provides a higher availability of the services through a node if a CSM should fail. If one fails, the redundant hot-standby CSM will take over automatically to keep the node and all its services alive (with a minimal service interrupt).

A manual switchover is also possible via the NSM, CSM or HiProvision.

For more information, see Ref. [3] in Table 1.

2.5 IFM (=Interface Module)

All peripherals are connected to the Dragon PTN Network via IFMs, which are available for a wide range of applications in the areas of data and LAN.

Each IFM has its own manual, which can be found on the Portal (= <https://hiprovision.hirschmann.com>) via Shortcuts → Manuals.

Dragon PTN nodes can provide slots for up to ten IFMs. Both low speed (1G) and high speed (10G) IFMs can be used together in the same node. The slot in which the IFM can be used depends on the IFM speed type (1G, 4x1G or 10G) and the node type slot speeds.

Verify the 'Dragon PTN Bandwidth Overview' manual (see Ref.[7] in Table 1) to find out in which IFM slots your IFM can be used.

For the correct programming of the IFMs, see the module manuals and HiProvision.

2.6 Backplane

The backplane interface provides for status & control communication between the IFMs, NSM, PSUs and CSM. The CSM communicates its status & control data with HiProvision. User data communication occurs between IFMs and the CSM. The IFMs are connected in a star configuration to the CSM resulting in an individual data bus for each IFM. Data transfer is full duplex. The Backplane Edition and Node Chassis Edition are factory set and cannot be changed. These editions can be read out via HiProvision.

2.7 PE: Protective Earth

A PE (=Protective Earth) point is provided on the left-hand side panel of the node. The PE connection ensures that all exposed conductive surfaces have the same electrical potential as the surface of the earth.

It avoids the risk of an electrical shock if a person touches a device in which an insulation fault has occurred. An insulation fault (a "short circuit") will cause a very high current flow, which will trigger an overcurrent protection device (fuse, circuit breaker) and disconnects the power supply.

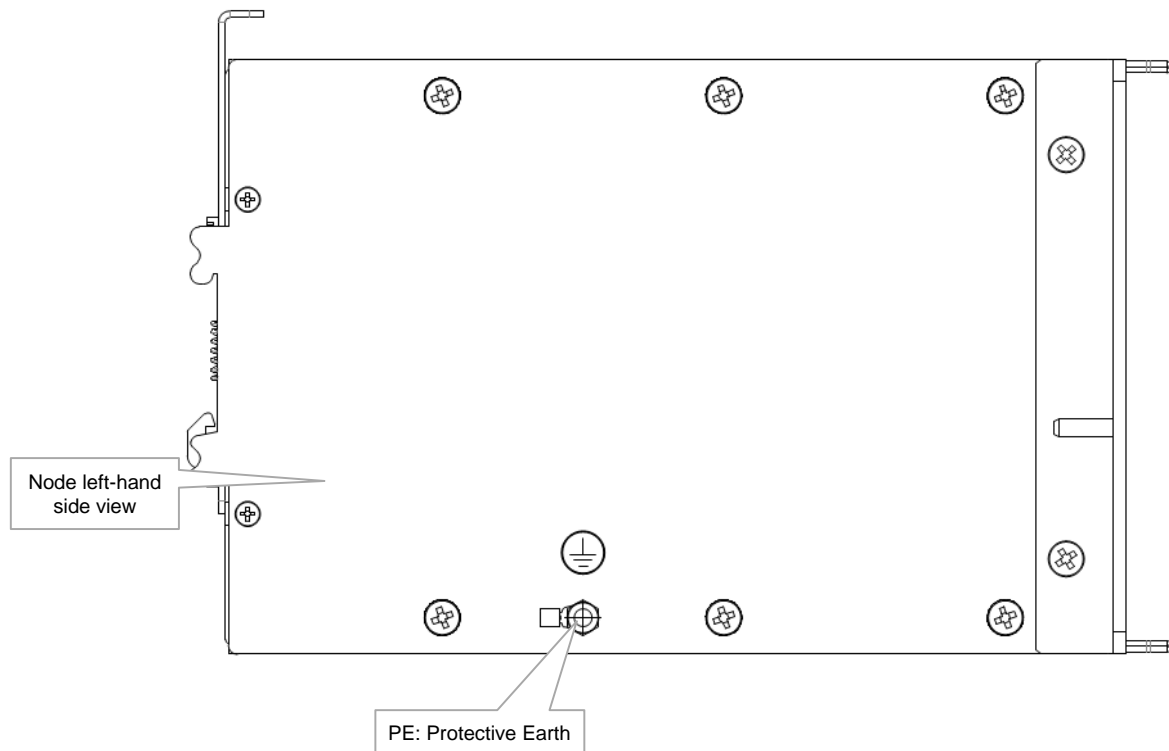

Figure 20 PE: Protective Earth

2.8 Cooling / Temperature Sensing

CAUTION:

- 1) There must be at least 3 U free ventilation space below and above the node!
- 2) Make sure that all empty slots are covered with cover plates, see 0.

The Dragon PTN Nodes have a rugged industrial design and operate, except for the 9-L3A-L IFM (see Ref.[6] in Table 1), entirely fanless (no moving parts). The cooling in the Dragon PTN nodes occurs via natural convection. For this reason no other equipment can be installed directly above or below the Dragon PTN node.

Each IFM or CSM hosts several temperature sensors which can be read out via HiProvision. When a temperature sensor goes beyond its allowed temperature range, an appropriate temperature alarm will be triggered via HiProvision.

2.9 Add a New Node to a Live Network

See Ref.[2] in Table 1.

3. SPECIFICATIONS

3.1 General Specifications

For general specifications like temperature, humidity, EMI... see Ref.[5] in Table 1.

3.2 Weight

Table 14 Product Weights

Description	Weight
Node: XT-2210-A (empty)	3.5 kg / 7.7 lb
Node: XT-2209-A (empty)	3.0 kg / 7.7 lb
Node: XT-2206-A (empty)	3.0 kg / 6.6 lb
Node: XT-1104-A (empty)	2.0 kg / 4.4 lb
Node Support Module (NSM-A)	0.21 kg / 0.5 lb
Node Support Module (NSM-B)	0.18 kg / 0.4 lb
AC PSU 100 to 240 VAC \pm 10 %	0.91 kg / 2.0 lb
DC PSU 18 to 60 VDC	0.9 kg / 2.0 lb
DC PSU 88 to 300 VDC	0.9 kg / 2.0 lb
ACPoE-A External DIN rail PSU (=AC 100-240 VAC Wide-range Input)	1.0 kg / 2.2 lb
DCPoE-A External DIN rail PSU (=33-62V Input)	1.2 kg / 2.6 lb

3.3 MTBF

- ▶ MTBF of the PSU: > 34 years at 25°C/77°F;
- ▶ MTBF of the NSM-A: 437 years at 25°C/77°F;
- ▶ MTBF of the NSM-B: pending;
- ▶ MTBF of the backplane: 665 years at 25°C/77°F.

3.4 Power Consumption (Empty Node)

Table 15 Power Consumption

Description	Node XT-2210-A Node XT-2209-A Node XT-2206-A Node XT-1104-A
AC PSU + backplane + NSM + CSM	35 W

3.5 Dimensions

- ▶ Node XT-2210-A/XT-2209-A
 - ▶ width: 482 mm / 18.98 inches;
 - ▶ height: 132.5 mm / 5.22 inches (3 U);
 - ▶ depth: 220 mm / 8.66 inches (including DIN Rail system).

- ▶ Node XT-2206-A
 - ▶ width: 353.5 mm / 13.9 inches;
 - ▶ height: 132.5 mm / 5.22 inches (3 U);
 - ▶ depth: 220 mm / 8.66 inches (including DIN Rail system).
- ▶ Node XT-1104-A
 - ▶ width: 211 mm / 8.31 inches;
 - ▶ height: 132.5 mm / 5.22 inches (3 U);
 - ▶ depth: 220 mm / 8.66 inches (including DIN Rail system).

3.6 Cooling

See §2.8.

3.7 Input Voltage Range

- ▶ 942 234-001: High voltage PSU 100 to 240 VAC \pm 10 %;
- ▶ 942 234-002: Low voltage PSU 18 to 60 VDC;
- ▶ 942 234-003: High voltage PSU 88 to 300 VDC.

3.8 Digital Output Contacts

- ▶ Maximum current: 1A DC;
- ▶ Maximum voltage: 60V DC;
- ▶ See also §2.2.2g;

3.9 Ordering Information

See 0.

4. INSTALLATION INSTRUCTIONS

Instructions for node installation can be found in document Ref. [2] in Table 1.

CAUTION:

Double pole/neutral fusing.

CAUTION:

First connect the GND (Ground) to the housing of the node before connecting the mains voltage. Only the mains voltage plug can disconnect the node's mains voltage. For DC input PSUs: never apply an excess input voltage and respect the correct polarity. The PSU might get damaged when an incorrect voltage source has been connected!

5. WEEE GUIDELINES

The Dragon PTN nodes are compliant with the European guidelines 2002/96/EG (WEEE = Waste of Electrical and Electronic Equipment). This compliancy is indicated at the back of the node by a crossed-bin symbol in Figure 21.



Figure 21 Crossed-Bin Symbol

The equipment that you bought required the extraction and use of natural resources for its production. It may contain substances that are hazardous to human health and the environment.

In order to avoid the dissemination of those substances in our environment and to reduce the pressure on the natural resources, we encourage you to use the appropriate take-back systems. These systems will reuse or recycle most of the materials of your end-of-life equipment in a sound way.

The crossed-bin symbol invites you to use those systems.

If you need more information on the collection, reuse and recycling systems, please contact your local or regional waste administration. You can also contact us for more information on the environmental performances of our product.

6. ABBREVIATIONS

AC	Alternate Current
CE	Conformité Européenne
CSM	Central Switching Module
DC	Direct Current
DI	Digital Input
DIN	Deutsches Institut für Normung
DO	Digital Output
EMC	Electromagnetic Compatibility
EMI	Electromagnetic Interference
GND	Ground
IEEE	Institute of Electrical and Electronics Engineers
IFM	InterFace Module
LAN	Local Area Network
MPLS-TP	Multiprotocol Label Switching – Transport Profile
MSB	Most Significant Bit
MTBF	Mean Time Between Failures
NSM	Node Support Module

PD	Powered Device
PE	Protective Earth
PI	Power Input
PoE	Power Over Ethernet
PSE	Power Source Equipment
PSI	Power Supply Input
PSO	Power Supply Output
PSU	Power Supply Unit
PTN	Packet Transport Network
SHDSL	Symmetrical High Bitrate Digital Subscriber Line
U	Rack Unit
WAN	Wide Area Network
WEEE	Waste of Electrical and Electronic Equipment